

Agilent 4288A 1 kHz/1 MHz Capacitance Meter

Programming Manual

Third Edition

FIRMWARE REVISIONS/SERIAL NUMBERS

This manual applies directly to instruments that have the firmware revision 1.2x and serial number prefix JP1KH.
For additional information about firmware revisions and serial numbers, see Appendix A.



Agilent Technologies

Agilent Part No. 04288-90021

December 2001

Printed in Japan

Notices

The information contained in this document is subject to change without notice.

This document contains proprietary information that is protected by copyright. All rights are reserved. No part of this document may be photocopied, reproduced, or translated to another language without the prior written consent of Agilent Technologies.

Agilent Technologies Japan, Ltd.

Component Test PGU-Kobe

1-3-2, Murotani, Nishi-ku, Kobe, Hyogo, 651-2241 Japan

© Copyright 2000, 2001 Agilent Technologies Japan, Ltd.

Manual Printing History

The manual's printing date and part number indicate its current edition. The printing date changes when a new edition is printed (minor corrections and updates that are incorporated at reprint do not cause the date to change). The manual part number changes when extensive technical changes are incorporated.

December 2000 First Edition (part number: 04288-90001)

July 2001 Second Edition (part number: 04288-90011)

December 2001 Third Edition (part number: 04288-90021)

Typeface Conventions

Bold	Boldface type is used when a term is defined. For example: icons are symbols.
<i>Italic</i>	Italic type is used for emphasis and for titles of manuals and other publications.
[Key]	Indicates the hardkey whose key label is Key.
[Blue] - [Key]	Indicates that you press the blue shift key to activate the shift function (2nd function printed in blue) and then press the hardkey whose key label (printed in dark gray) is Key.
[Key] - Item	Indicates a series of key operations in which you press the [Key] key, make the item called Item on the displayed menu blink by using the [←↓] and other keys, and then press the [Enter] key.

Sample Program Disk

A sample program disk (Agilent part number: 04288-18000) is furnished with this manual. The disk contains the sample programs used in this manual.

The customer shall have the personal, non-transferable rights to use, copy, or modify SAMPLE PROGRAMS in this manual for the customer's internal operations. The customer shall use the SAMPLE PROGRAMS solely and exclusively for their own purposes and shall not license, lease, market, or distribute the SAMPLE PROGRAMS or modification of any part thereof.

Agilent Technologies shall not be liable for the quality, performance, or behavior of the SAMPLE PROGRAMS. Agilent Technologies especially disclaims any responsibility for the operation of the SAMPLE PROGRAMS to be uninterrupted or error-free. The SAMPLE PROGRAMS are provided AS IS.

AGILENT TECHNOLOGIES DISCLAIMS ANY IMPLIED WARRANTY OF MERCHANTABILITY AND FITNESS FOR A PARTICULAR PURPOSE.

Agilent Technologies shall not be liable for any infringement of any patent, trademark, copyright, or other proprietary right by the SAMPLE PROGRAMS or their use. Agilent Technologies does not warrant that the SAMPLE PROGRAMS are free from infringements of such rights of third parties. However, Agilent Technologies will not knowingly infringe or deliver software that infringes the patent, trademark, copyright, or other proprietary right of a third party.

4288A Documentation Map

The following manuals are available for the 4288A.

- ***Operation Manual (Agilent P/N: 04288-900x0)***

Most of the basic information necessary for using the 4288A is provided in the *Operation Manual*. It describes installation, preparation, measurement operation including calibration, performances (specifications), and error messages. For GPIB programming, see the *Programming Manual*.

- ***Programming Manual (Agilent P/N: 04288-900x1)***

The *Programming Manual* shows how to write and use the BASIC program to control the 4288A.

1. Making Effective Use of This Manual	
Contents of This Manual	12
How To Use This Manual	14
Looking up GPIB commands	14
Using sample programs	15
2. Overview of Remote Control	
Setting Up a GPIB Remote Control System	18
What is GPIB?	18
How to set up a GPIB remote control system	18
Device selector	19
Sending GPIB Command Messages	21
Types and structure of GPIB commands	21
Message syntax	22
3. Setting Up Measurement Conditions and Display	
Setting Up Measurement Conditions	24
Selecting measurement parameters	24
Setting up measurement signal (frequency and level)	24
Selecting measurement range	25
Selecting measurement time	25
Selecting cable length	25
Setting up averaging function	25
Setting up trigger delay time	25
Setting Up Display	26
Turning ON/OFF display	26
Setting up measurement result display	26
Selecting items displayed in instrument setup display area	26
Displaying measurement result as deviation from reference value (deviation measurement mode)	27
Monitoring Measurement Signal Level	28
Turning ON current level monitor function	28
Turning ON voltage level monitor function	28
Setting Up Beep	29
Setting up conditions to make a beep sound	29
Making a beep sound	29
Saving/Recalling Instrument Setup State (save/recall function)	30
Saving instrument setup state	30
Recalling saved instrument setup state	30
Sample Program	31
4. Preparation for Accurate Measurement (Executing Compensation)	
Executing OPEN/SHORT/LOAD Compensation	36
Turning ON/OFF compensation function	36
Measuring compensation data	36
Reading/writing compensation data (saving/recalling compensation conditions)	37
Avoiding work-related mistakes in measuring compensation data	37
Sample program	38
Executing Offset Compensation	45

Turning ON/OFF the compensation function	45
Setting up the compensation data	45
Using the Multi-compensation Function	46
Turning ON/OFF the multi-compensation function	46
Selecting a channel	46
Measuring compensation data	46
Sample program	47
5. Starting (Triggering) Measurement and Waiting for Completion of Measurement	
Starting (triggering) Measurement	52
Trigger system.	52
Starting (triggering) measurement	54
Waiting For Completion Of Measurement (detecting completion of measurement)	55
Sample program	56
6. Reading Out Measured Result	
Data Transfer Format	58
ASCII transfer format.	59
Binary transfer format.	60
Reading Out Measured Result	61
Reading out measured result using *TRG command	62
Reading out measured result using :FETC? command	66
Reading out measured result using :READ? command.	70
Reading out results of several measurements in batch (using data buffer).	75
Reading out measurement signal level monitor result	79
7. Sorting Based on Measured Result (Comparator Function)	
Setting Up Comparator Function	82
Turning ON/OFF comparator function.	82
Setting up limit range	82
Turning ON/OFF AUX BIN function.	84
Setting up condition to make a beep sound	84
Rejecting Excessively Low Measured Results (Low C reject function)	85
Turning ON/OFF Low C reject function	85
Setting limit (range boundary values) of Low C reject function	85
Reading Out Sorting Judgment Result	86
Reading Out Sort Count Of Each Bin (BIN count function)	88
Turning ON/OFF BIN count function	88
Reading out BIN count value	88
Clearing (resetting) the BIN count value	88
Sample Program	89
8. Avoiding Mistakes Related to Work and Daily Checks	
Avoiding Mistakes Related To Work	94
Avoiding improper input from the front panel (key lock function)	94
Avoiding mistakes related to work when obtaining compensation data.	94
Detecting the occurrence of an error.	95
Daily Checks (executing the self-test)	98

Internal test	98
External test.	98
Sample program	99
9. Measurement Applications (Sample Programs)	
Basic Capacitor Measurement	102
Measurement with Auto-sorting System	106
Measurement with changing channels (scanning)	113
10. Command Reference	
Notational conventions in this command reference	122
Syntax	122
Description	122
Parameters	122
Query response	123
Related commands	123
Equivalent key sequence	123
IEEE Common Commands	124
*CLS	124
*ESE	124
*ESR?	125
*IDN?	125
*OPC	125
*OPC?	125
*OPT?	126
*RCL	126
*RST	126
*SAV	127
*SRE	127
*STB?	128
*TRG	128
*TST?	129
*WAI	129
4288A GPIB Commands	130
:ABOR	130
:APER	130
:AVER	131
:AVER:COUN	132
:CAL:CABL	133
:CAL:COMP	134
:CAL:COMP:AUXB	135
:CAL:COMP:BEEP	135
:CAL:COMP:BEEP:COND	136
:CAL:COMP:CLE	136
:CAL:COMP:COUN	137
:CAL:COMP:COUN:CLE	137
:CAL:COMP:COUN:DATA?	138
:CAL:COMP:COUN:MULT:DATA?	139

Contents

:CALC:COMP:COUN:MULT:OVLD?	140
:CALC:COMP:COUN:OVLD?	140
:CALC:COMP:MODE	141
:CALC:COMP:PRIM:BIN{1-9}	142
:CALC:COMP:PRIM:BIN{1-9}:STAT	143
:CALC:COMP:PRIM:NOM	144
:CALC:COMP:SEC:LIM	145
:CALC:COMP:SEC:STAT	146
:CALC1:FORM	147
:CALC1:MATH:EXPR:CAT?	147
:CALC1:MATH:EXPR:NAME	148
:CALC1:MATH:STAT	149
:CALC2:FORM	150
:CALC2:MATH:EXPR:CAT?	150
:CALC2:MATH:EXPR:NAME	151
:CALC2:MATH:STAT	152
:CALC3:MATH:STAT	153
:CALC4:MATH:STAT	153
:CORR:CKIT:STAN1:FORM	154
:CORR:CKIT:STAN2:FORM	154
:CORR:CKIT:STAN3	155
:CORR:CKIT:STAN3:FORM	156
:CORR:COLL	157
:CORR:DATA	158
:CORR:LOAD	160
:CORR:MULT	161
:CORR:MULT:CHAN	161
:CORR:MULT:CKIT:STAN3	162
:CORR:OFFS	163
:CORR:OFFS:DATA	164
:CORR:OPEN	165
:CORR:SHOR	165
:CREJ	166
:CREJ:LIM	167
:DATA	168
:DATA:FEED	173
:DATA:FEED:CONT	174
:DATA:POIN	175
:DISP	176
:DISP:TEXT1:DIG	176
:DISP:TEXT1:FMSD	177
:DISP:TEXT1:FMSD:DATA	178
:DISP:TEXT2:PAGE	179
:FETC?	181
:FORM	182
:INIT	183
:INIT:CONT	183
:RANG	184
:RANG:AUTO	185

:READ?	186
:SOUR:FREQ	187
:SOUR:VOLT	188
:STAT:OPER?	189
:STAT:OPER:COND?	189
:STAT:OPER:ENAB	189
:STAT:PRES	190
:STAT:QUES?	190
:STAT:QUES:COND?	190
:STAT:QUES:ENAB	190
:SYST:BEEP	191
:SYST:BEEP:STAT	191
:SYST:ERR?	192
:SYST:FSH	192
:SYST:KLOC	193
:SYST:PRES	193
:SYST:TEST?	194
:SYST:VERS?	194
:TRIG	195
:TRIG:DEL	195
:TRIG:SOUR	196
GPIB Command Table	197
Front Panel Key Tree vs. GPIB Command	201
GPIB Command Tree	203

A. Manual Changes

Manual Changes	208
Change 1	209
Change 2	209

B. Information for Replacing 4278A with 4288A

Functional Comparison and GPIB Command Correspondence	212
Reset	212
Measurement parameters	212
Measurement signal	213
High-accuracy measurement (HI-ACC) mode	213
Measurement range	214
Integration time (measurement time)/averaging	216
Cable length	216
Trigger/delay (trigger delay) time	217
Compensation	218
Multi-compensation	220
Comparator	221
Display	224
Reading out the measurement result	228
Save/recall and resume	230
Status registers (status report system)	230
Example of Replacing Major Functions (comparison of programs)	232

Comparator	232
Reading out the measurement result	234
Compensation	236
Status register (status report system)	237
At-a-Glance List of GPIB Command Correspondence	238
Comparison of Interfaces	244
Handler interface.	244
Scanner interface.	245
C. Status Reporting System	
General Status Register Model.	248
Event register	249
Enable register	249
Status byte register	249
Condition register and transition filter	250
Status Register Structure	251
Using the Status Reporting System	255
D. Initial Settings	
Initial Settings, Settings that can be Saved/Recalled, Settings that can be Backed Up	258
E. At-a-glance Table of Operations When Overload or Low C is Detected	
Operations when overload/Low C is detected	262
F. Error Messages	
Error messages (order of error number).	264
Warning Messages (WARNING).	272
G. 4268A vs. 4288A GPIB Command Correspondence Table	
4268A vs. 4288A GPIB Command Correspondence Table	274

1 Making Effective Use of This Manual

This chapter provides an overview of this manual as well as useful information to help you navigate through the manual. It also briefly describes how to use this manual, focusing on how you can look up particular commands.

Contents of This Manual

This manual is a programming guide for the Agilent 4288A 1 kHz/1 MHz capacitance meter. In addition to explanations of how to remotely control the 4288A from BASIC programs, it provides listings and in-depth descriptions of sample HTBasic programs. The chapter-by-chapter contents of this manual are as follows.

Chapter 1 “Making Effective Use of This Manual”

This chapter provides an overview of this manual as well as useful information to help you navigate through the manual. It also briefly describes how to use this manual, focusing on how you can look up particular commands.

Chapter 2 “Overview of Remote Control”

This chapter gives an overview of the GPIB remote control system and GPIB commands.

Chapter 3 “Setting Up Measurement Conditions and Display”

This chapter describes how to set up the measurement conditions and display. It also describes how to save/recall the instrument settings including the measurement conditions.

Chapter 4 “Preparation for Accurate Measurement (Executing Compensation)”

This chapter describes how to execute the compensation function.

Chapter 5 “Starting (Triggering) Measurement and Waiting for Completion of Measurement”

This chapter describes how to trigger the instrument to start measurement and how to detect completion of measurement.

Chapter 6 “Reading Out Measured Result”

This chapter describes how to read out the measured result and the measurement signal level monitor result.

Chapter 7 “Sorting Based on Measured Result (Comparator Function)”

This chapter describes how to use the comparator function to perform sorting based on the measured result.

Chapter 8 “Avoiding Mistakes Related to Work and Daily Checks”

This chapter describes how to avoid simple mistakes related to work, how to detect the occurrence of an error, and how to execute the self-test.

Chapter 9 “Measurement Applications (Sample Programs)”

This chapter contains sample programs for both basic measurement and measurement using a system integrated with the handler/scanner interface.

Chapter 10 “Command Reference”

This chapter provides the GPIB command reference for the Agilent 4288A. Each command is fully described and ordered alphabetically based on its abbreviated name format. Use the index to look up a GPIB command by its full syntax. To find a command according to its function, refer to the “GPIB Command Table” on page 197.

Appendix A “Manual Changes”

This appendix contains the information required to adapt this manual to earlier versions or configurations of the Agilent 4288A than that indicated by the current printing date of this manual. The information in this manual applies directly to the 4288A model that has the serial number prefix listed on the title page of this manual.

Appendix B “Information for Replacing 4278A with 4288A”

This appendix describes information that is applicable when replacing the Agilent 4278A with the Agilent 4288A. See the 4278A Operation Manual for more detailed information on the 4278A. See the 4288A Operation Manual and the other chapters of this manual (Programming Manual) for more detailed information on the 4288A.

Appendix C “Status Reporting System”

This appendix describes the status reporting system of the Agilent 4288A.

Appendix D “Initial Settings”

This appendix provides initial settings, settings that can be saved/recalled, and settings that can be backed up.

Appendix E “At-a-glance Table of Operations When Overload or Low C is Detected”

This appendix describes display output, GPIB output, and handler interface output when an overload or Low C is detected.

Appendix F “Error Messages”

The Agilent 4288A provides error messages to indicate its operating status. This appendix describes the error messages of the 4288A in order of error number. To search for error messages alphabetically, refer to the Operation Manual.

Appendix G “4268A vs. 4288A GPIB Command Correspondence Table”

This appendix gives the correspondence between the Agilent 4268A GPIB commands and those of the Agilent 4288A.

How To Use This Manual

Chapters 3 to 8 provide task-based descriptions of GPIB commands that are useful for programming and explain how you can use them. These chapters contain explanations and sample program listings that you can use to develop your custom programs. For more information on individual commands, see Chapter 10, “Command Reference.”

Looking up GPIB commands

Chapter 10, “Command Reference,” contains a complete reference of GPIB commands. You can look up a particular GPIB command in any of the following ways:

Lookup by Abbreviated Command Name

The command reference is organized alphabetically according to the abbreviated name used as the title for each command’s description.

Lookup by Full Command Name

You can use the index at the end of the manual to find full command names along with the page numbers where they appear.

Lookup by Command Function

Table 10-2 on page 197 provides a complete list of commands by function and indicates the page numbers where the commands appear in the command reference.

Lookup by Front panel key

Table 10-3 on page 201 provides a complete list of commands that correspond to the front panel key tree and indicates the page numbers where the commands appear in the command reference.

NOTE

Some GPIB commands supported by the 4288A have optional syntax elements. In the command reference conventions, these elements are enclosed between square brackets ([]) or printed in lowercase letters. See “Syntax” on page 122 for more information.

Using sample programs

This manual comes with a sample program disk, which contains the source files of the sample programs used in the manual. The disk is DOS-formatted and the files are saved in ASCII format.

Loading a sample program

To load a sample program into the HTBasic interpreter, use the GET command. For example, you can load setup.bas, one of the sample programs, by the following procedure:

In the HTBasic screen, type the following command and press the Return key.

```
GET "setup.bas"
```

Looking up a sample program

To look up the description of a sample program, see the listings under "Sample program" in the index.

Making Effective Use of This Manual
How To Use This Manual

2 Overview of Remote Control

This chapter gives an overview of the GPIB remote control system and GPIB commands.

Setting Up a GPIB Remote Control System

This section describes how to set up a GPIB remote control system.

What is GPIB?

GPIB (General Purpose Interface Bus) is an interface standard for connecting a computer with peripherals. It complies with these international standards: IEEE 488.1, IEC-625, IEEE 488.2, and JIS-C1901. With the GPIB interface, you can set up a GPIB remote control system in which an external computer remotely controls the Agilent 4288A by sending commands to and receiving data from the unit through the GPIB bus.

How to set up a GPIB remote control system

Use GPIB cables to connect the 4288A to an external controller (computer) and any necessary peripherals. Figure 2-1 shows a typical GPIB remote control system.

Figure 2-1

Setting up a GPIB remote control system

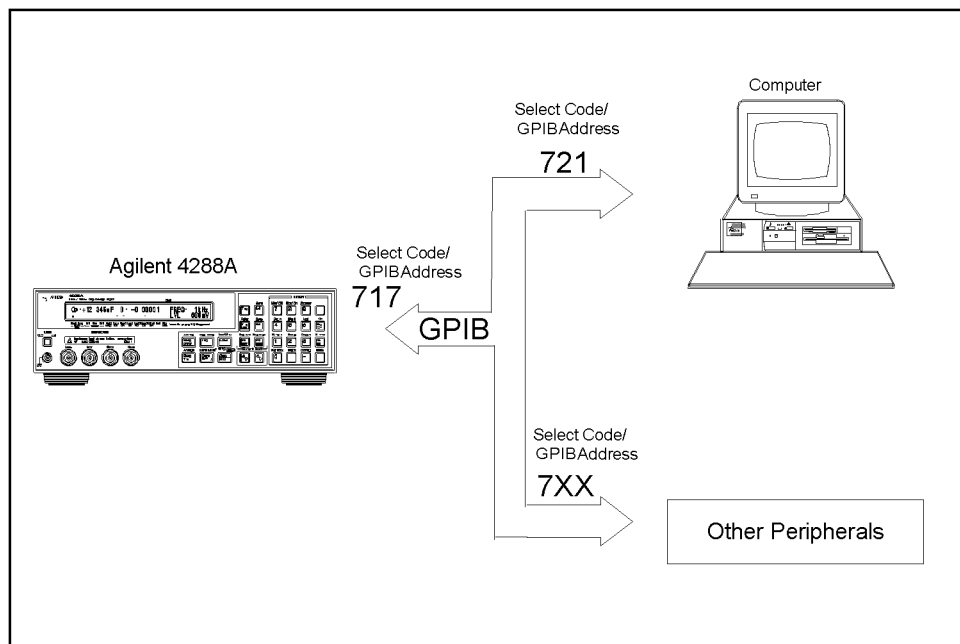

4288ape001

Required equipment

1. 4288A with accessories for measuring DUTs
2. External controller (computer)
The external controller can be any personal computer or workstation with a GPIB interface card and the appropriate software (such as HTBasic) for controlling the instrument via the GPIB interface.
3. Other hardware as needed (extra instruments and/or peripherals)
4. GPIB cables for connecting the 4288A to the external controller and other hardware

Possible sizes and configurations of your remote control system

- One GPIB system can host up to 15 devices.
- Device-to-device cables should be no longer than 4 m. The total length of connection cables used in one GPIB system should not exceed $2 \text{ m} \times N$, where N is the number of connected devices (including controller). In any case, do not construct a system whose total cable length exceeds 20 m.
- Do not connect any single device with more than four connectors. Doing so exposes the connectors to excessive strain, possibly causing a failure.
- The topology of device connections can be star, linear, or a combination of them. Loop connections are not supported.

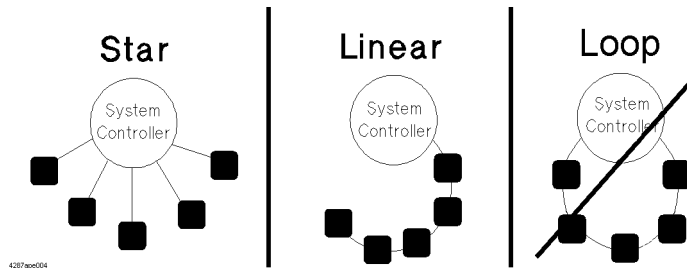

Device selector

Each device is assigned a unique identifier called the “device selector.” When the controller attempts to control (communicate messages with) one of the devices connected over the GPIB remote control system, it selects that device with the appropriate device selector.

A device selector consists of a select code (normally 7) and a GPIB address. For example, when the select code is 7 and the GPIB address is 17, the device selector is 717. The select code is system-global. Each device in the same system is assigned a GPIB address that uniquely identifies it. When this document refers to a device selector in descriptive text or sample programs, it is always assumed to be 717. Use the following procedure to set the GPIB address of the 4288A.

Overview of Remote Control
Setting Up a GPIB Remote Control System

Setting the GPIB address for the Agilent 4288A

Step 1. Press the [Adrs] ([Blue] - [Lcl]) key. This brings up the screen shown in Figure 2-2, where the initial value is the current setup of the address (in this example, 17).

Figure 2-2 GPIB address setup screen

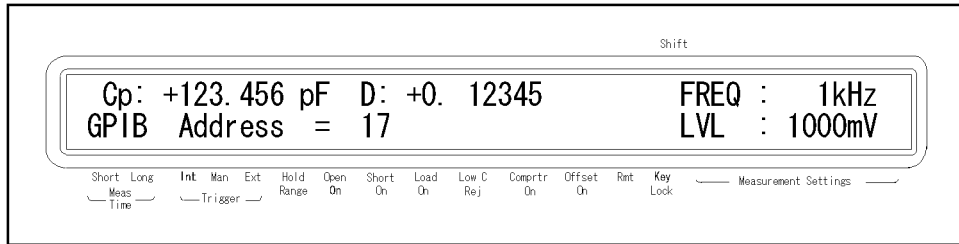

4288api002

Step 2. Use the numeric and other necessary keys to enter the address and then press the [Enter] key.

Sending GPIB Command Messages

Types and structure of GPIB commands

GPIB commands available with the 4288A can be divided into two groups:

4288A-specific commands

These commands are specific to the 4288A. They provide access to all measurement features and some generic features built into the 4288A. Commands in this group have a hierarchical (multi-level) structure called the “command tree” (see “GPIB Command Tree” on page 203). Each command consists of multi-level strings (mnemonics) and colons (:) that delimit the levels of the hierarchy.

IEEE common commands

These are commands that provide access to generic features defined by IEEE488.2. They are accepted by any instrument that complies with IEEE488.2. Each command in this group is prefixed with an asterisk (*). These commands have no hierarchical levels.

Command tree concept

The topmost command in the command tree is referred to as the “root command,” or simply the “root.” To access a lower-level command in the command tree, you must specify the appropriate path, which looks like a directory path in the DOS file system. Turning on the power or resetting the instrument changes the current path to the root. Also, different path settings are used depending on the special symbols contained in messages:

Message terminators

When a message terminator such as <new line> is detected, the current path is set to the root.

Colons (:)

When a colon is detected between two command mnemonics, the current path is changed to the next lower level. When a colon is detected at the beginning of a command, the command mnemonic that follows is specified as the root level command.

Semicolons (;)

A semicolon is used to delimit two commands contained in the same message without changing the current path.

Figure 2-3 illustrates how colons and semicolons can be used to efficiently access various commands in the command tree.

Figure 2-3

Using colons and semicolons

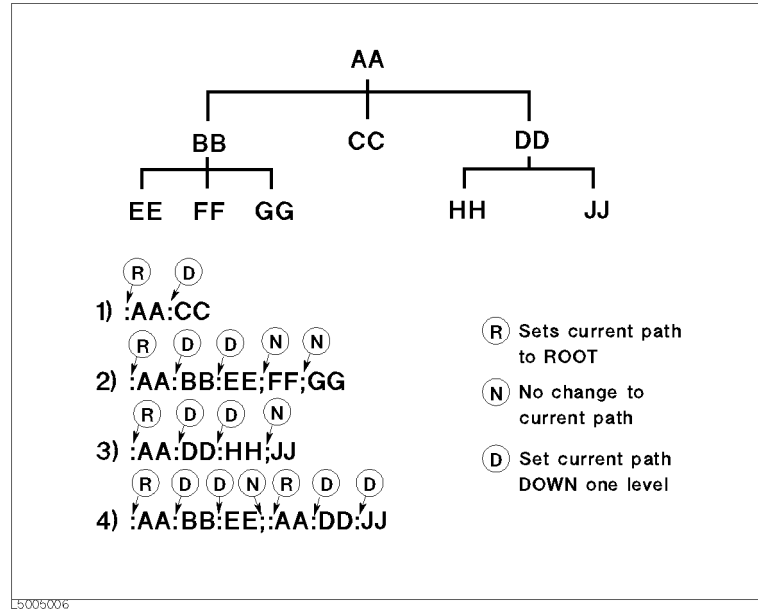

Message syntax

This section describes the syntax for sending program messages via GPIB. Program messages are sent by the user from an external controller to the instrument to control the instrument. A program message contains one or more commands along with any required parameters.

Case sensitivity

Program messages are not case sensitive.

Program message terminators

A program message must be terminated with one of three program message terminators: <new line>, <^END>, or <new line><^END>. The <^END> terminator ensures that the immediately preceding data byte is sent out and that EOI is set to the active level on the GPIB interface. For example, the OUTPUT command (HTBasic) automatically sends a message terminator following the last data byte.

Parameters

You must put a space character (ASCII code 32) between the command and the first parameter. When you send a command with two or more parameters, you must delimit the parameters with commas (,).

Multi-command messages

When you send a message that contains two or more commands, you must delimit the commands with semicolons (;). The following HTBasic example shows how to send a message that contains *CLS and :INIT commands.

```
OUTPUT 717; " *CLS; :INIT"
```

3 Setting Up Measurement Conditions and Display

This chapter describes how to set up the measurement conditions and display. It also describes how to save/recall the instrument settings including the measurement conditions.

Setting Up Measurement Conditions

Selecting measurement parameters

To select the measurement parameters, use the following commands.

- **:CALC1:FORM** on page 147
- **:CALC2:FORM** on page 150

You can select one of the following measurement parameter combinations shown in Table 3-1. If you select one parameter using the GPIB command and the resulting parameter combination is not among those in Table 3-1, the other parameter is automatically changed to a proper parameter. For example, when the primary parameter is Cp and you select Rs as the secondary parameter, the primary parameter is automatically changed to Cs.

Table 3-1

Measurement parameter combinations

Primary parameter	Secondary parameter
Cp	D, Q, G, Rp
Cs	D, Q, Rs

Each parameter is described below.

Cp:	Capacitance value measured using the parallel equivalent circuit model
Cs:	Capacitance value measured using the series equivalent circuit model
D:	Dissipation factor
Q:	Quality factor (inverse of D)
G:	Equivalent parallel conductance measured using the parallel equivalent circuit model
Rp:	Equivalent parallel resistance measured using the parallel equivalent circuit model
Rs:	Equivalent series resistance measured using the series equivalent circuit model

Setting up measurement signal (frequency and level)

Setting up frequency

To select the measurement signal frequency (1 kHz/1 MHz), use the following command.

- **:SOUR:FREQ** on page 187

Setting up level

To set the measurement signal level, use the following command.

- **:SOUR:VOLT** on page 188

Selecting measurement range

Selecting measurement range mode

To select the measurement range mode (auto range/hold range), use the following command.

- **:RANG:AUTO** on page 185

Selecting measurement range

To select the measurement range, use the following command.

- **:RANG** on page 184

The selectable measurement ranges differ depending on the measurement signal frequency. Therefore, if a newly selected measurement frequency conflicts with the current measurement range setting, the setting automatically changes to cover the allowable range.

NOTE

Setting up the measurement range automatically sets up the measurement range mode to the hold range mode.

Selecting measurement time

To select the measurement time (short mode/long mode), use the following command.

- **:APER** on page 130

Selecting cable length

To set the cable length (0 m/1 m/2 m), use the following command.

- **:CAL:CABL** on page 133

Setting up averaging function

Turning ON/OFF averaging function

To turn ON/OFF the averaging function, use the following command.

- **:AVER** on page 131

Setting up averaging count

To set the averaging count, use the following command.

- **:AVER:COUN** on page 132

Setting up trigger delay time

To set the trigger delay time, use the following command.

- **:TRIG:DEL** on page 195

Setting Up Display

Turning ON/OFF display

To turn ON/OFF display of the measurement parameter obtained, the measurement signal level monitored, the handler output (comparator sorting result), the multi-compensation settings, and the compensation data, use the following command.

- **:DISP** on page 176

Setting up measurement result display

You can set up the following items related to the measurement result display.

- Number of display digits
- Fixed point display
 - ON/OFF
 - Value of highest digit

The following table shows the commands used to set up the above items.

Setup item		Command
Number of display digits		:DISP:TEXT1:DIG on page 176
Fixed point display	ON/OFF	:DISP:TEXT1:FMSD on page 177
	Value of highest digit	:DISP:TEXT1:FMSD:DATA on page 178

Selecting items displayed in instrument setup display area

To select a display page for the part that displays the instrument setup at the right of the display (instrument setup display area), use the following command.

- **:DISP:TEXT2:PAGE** on page 179

Displaying measurement result as deviation from reference value (deviation measurement mode)

You can use the deviation measurement mode to display a relative measurement result as deviation from the reference value instead of displaying its absolute value. To turn ON/OFF the deviation measurement mode, use the following commands.

- **:CALC1:MATH:STAT** on page 149
- **:CALC2:MATH:STAT** on page 152

You can select from two modes in the deviation measurement mode: displaying the deviation as it is or displaying the deviation as a percentage relative to the reference value. To set the deviation measurement mode, use the following commands.

- **:CALC1:MATH:EXPR:NAME** on page 148
- **:CALC2:MATH:EXPR:NAME** on page 151

To set the reference value in the deviation measurement mode, use the following command.

- **:DATA {REF1|REF2}** on page 172

The table below shows the relationship between the setups using the above commands and the values displayed as the measurement result.

Setup of :CALC1:MATH:STAT or :CALC2:MATH:STAT	Setup of :CALC1:MATH:EXPR:NAME or :CALC2:MATH:EXPR:NAME	Value displayed as the measurement result
OFF	———	<i>Meas</i>
ON	DEV	<i>Meas - Ref</i>
	PCNT	$\frac{Meas - Ref}{Ref} \times 100$

Where, *Meas* and *Ref* are:

Meas : Measured value

Ref : Reference value (set using the **:DATA {REF1|REF2}** command)

NOTE

The measured value read out by the GPIB command is a calculation result based on the above setup. For judgment in the comparator function, the measurement result is used as is regardless of the setup. (Refer to the data processing flow in the *Operation Manual*.)

Monitoring Measurement Signal Level

Turning ON current level monitor function

To turn ON/OFF current level monitor function for the measurement signal, use the following command.

- **:CALC3:MATH:STAT** on page 153

Turning ON voltage level monitor function

To turn ON/OFF voltage level monitor function for the measurement signal, use the following command.

- **:CALC4:MATH:STAT** on page 153

Setting Up Beep

Setting up conditions to make a beep sound

To turn ON/OFF the beep sound, use one of the following commands. You can use either of these two commands since both functions are identical.

- **:CALC:COMP:BEEP** on page 135
- **:SYST:BEEP:STAT** on page 191

To set the conditions to make a beep sound according to the comparator sorting result, use the following command.

- **:CALC:COMP:BEEP:COND** on page 136

The table below shows the relationship between the settings made by the above commands and the condition to make a beep.

Setting of :CALC:COMP:BEEP or :SYST:BEEP:STAT	Setting of :CALC:COMP:BEEP: COND	Condition to make a beep	
OFF	——	Never make a beep sound	
ON	FAIL	<ul style="list-style-type: none"> •When wrong key operation is performed. 	<ul style="list-style-type: none"> •When the sorting judgment result of the comparator is OUT_OF_BIN or AUX_BIN.
	PASS	<ul style="list-style-type: none"> •When an error, alarm, or other message is output. 	<ul style="list-style-type: none"> •When the sorting judgment result of the comparator is within BIN1 to BIN9.

Making a beep sound

To make a beep sound, use the following command:

- **:SYST:BEEP** on page 191

Saving/Recalling Instrument Setup State (save/recall function)

You can save/recall up to 10 instrument settings into/from the built-in nonvolatile memory (EEPROM).

For information on the instrument setups you can save/recall, refer to Table D-1, “Initial settings, settings that can be saved/recalled, settings that can be backed up,” on page 259.

Saving instrument setup state

To save the instrument setup state, use the following command.

- ***SAV** on page 127

Recalling saved instrument setup state

To recall the saved instrument setup state, use the following command.

- ***RCL** on page 126

Sample Program

Example 3-1 shows a sample program to set up the measurement conditions and display. This program is stored on the sample program disk under the filename “setup.bas.”

This program performs reset, sets up the 4288A as shown in the following table, and saves the setups into the built-in nonvolatile memory (save location number: 9).

Item		Setup
Measurement parameter	Primary parameter	Cp
	Secondary parameter	D
Measurement signal	Frequency	1 kHz
	Level	500 mV
Measurement range		Auto range mode
Measurement time		Long mode
Averaging count		4
Cable length		0 m
Trigger delay time		1 ms
Display ON/OFF		ON
Number of display digits for the measurement result		5
Fixed point display for the measurement result		OFF
Deviation measurement mode (Primary parameter)	Mode	Percentage display
	Reference value	10 nF
Deviation measurement mode (Secondary parameter)	Mode	OFF
	Reference value	0
Page number of the instrument setup display area		4 (the page that displays the measurement signal level monitor result)
Measurement signal level monitor	Current	OFF
	Voltage	ON
Beep mode		FAIL

Setting Up Measurement Conditions and Display Sample Program

The details of each part of the program are described below.

Line 70	Sets up the GPIB address.
Lines 90 to 170	Assigns the measurement condition setups (primary parameter: Cp, secondary parameter: D, measurement signal frequency: 1 kHz, measurement signal level: 500 mV, measurement range: auto range mode, measurement time: long mode, cable length: 0 m, averaging count: 4, and trigger delay time: 1 ms) to the Pri\$, Sec\$, Freq, Level, Range\$, Meas_time\$, Cable, Ave, and Delay variables, respectively.
Lines 190 to 260	Assigns the display setups (result display: ON, the number of display digits for the measurement result: 5, fixed point display: OFF, deviation measurement mode for primary parameter: percentage display, reference value for primary parameter: 10 nF, deviation measurement mode for secondary parameter: OFF, reference value for secondary parameter: 0, page number of the instrument setup display area: 4) to the Disp\$, Digit, Fix_msd\$, Dev_mode_pri\$, Dev_ref_pri\$, Dev_mode_sec\$, Dev_ref_sec, and Page_no variables, respectively.
Lines 280 to 310	Assigns the measurement signal level monitor setups (current monitor: OFF, voltage monitor: ON, beep mode setup: FAIL, and save location number: 9) to I_mon\$, V_mon\$, Beep_mode\$, and Save_no variables, respectively.
Line 330	Executes a reset.
Lines 340 to 350	Specifies the primary parameter and secondary parameter as Pri\$ and Sec\$, respectively.
Lines 360 to 370	Specifies the measurement signal frequency and measurement signal level as Freq and Level, respectively.
Lines 380 to 430	If Range\$ is "Auto," specifies the measurement range mode as the auto range. Otherwise, specifies the measurement range mode as the hold range and the measurement range as Range\$.

NOTE

In this example, the measurement range mode is set to the hold mode before the measurement range is specified. However, in practice, you can omit the setup of the measurement range mode because setting up the measurement range automatically specifies the measurement range mode to the hold range.

Lines 440 to 450	Specifies the measurement time and cable length as Meas_time\$ and Cable, respectively.
Lines 460 to 470	Turns ON the averaging function and sets the averaging count to Ave.
Line 480	Specifies the trigger delay time as Delay.
Lines 500 to 510	Specifies the ON/OFF of the result display and the number of display digits for the measurement result as Disp\$ and Digit, respectively.
Lines 520 to 570	If Fix_msd\$ is "OFF," specifies the fixed point display as OFF. Otherwise, specifies the fixed point display as ON and sets the value of the highest digit to Fix_msd\$.

- Lines 580 to 640 If Dev_mode_pri\$ is "OFF," specifies the deviation measurement mode for the primary parameter as OFF. Otherwise, specifies the deviation measurement mode for the primary parameter as ON and specifies the deviation display method and the deviation reference value as Dev_mode_pri\$ and Dev_ref_pri, respectively.
- Lines 650 to 710 If Dev_mode_sec\$ is "OFF," specifies the deviation measurement mode for the secondary parameter as OFF. Otherwise, specifies the deviation measurement mode for the secondary parameter as ON and specifies the deviation display method and the deviation reference value as Dev_mode_pri\$ and Dev_ref_sec, respectively.
- Line 720 Specifies the page number of the instrument settings display area as Page_no.
- Lines 740 to 750 Specifies the ON/OFF state of the current monitor and that of the voltage monitor for the measurement signal level as I_mon\$ and V_mon\$, respectively.
- Lines 760 to 810 If Beep_mode\$ is "OFF," specifies the beep output as OFF. Otherwise, specifies it as ON and the beep mode as Beep_mode\$.
- Line 830 Saves the instrument settings into the built-in nonvolatile memory (save location number: Save_no).

Example 3-1

Setting up measurement conditions and display (setup.bas)

```

10 DIM Pri$(9),Sec$(9),Range$(9),Meas_time$(9)
20 DIM Disp$(9),Fix_msd$(9),Dev_mode_pri$(9),Dev_mode_sec$(9)
30 DIM I_mon$(9),V_mon$(9),Beep_mode$(9)
40 REAL Freq,Level,Delay,Dev_ref_pri,Dev_ref_sec
50 INTEGER Cable,Ave,Digit,Page_no,Save_no
60 !
70 ASSIGN @Agt4288a TO 717
80 !
90 Pri$="CP" ! Meas. Parameter Primary : Cp
100 Sec$="D" ! Secondary: D
110 Freq=1000 ! Test Signal Frequency: 1 kHz
120 Level=.5 ! Level : 500 mV
130 Range$="AUTO" ! Meas. Range : Auto
140 Meas_time$="LONG" ! Meas. Time Mode : Long
150 Cable=0 ! Cable Length : 0 m
160 Ave=4 ! Averaging Factor : 4
170 Delay=.001 ! Trigger Delay Time : 1 ms
180 !
190 Disp$="ON" ! Display : On
200 Digit=5 ! Digit : 5
210 Fix_msd$="OFF" ! Fixed Decimal Point Display : Off
220 Dev_mode_pri$="PCNT" ! Deviation [Pri] Mode : Percent
230 Dev_ref_pri=1.0E-8 ! Measurement Ref.Value: 10 nF
240 Dev_mode_sec$="OFF" ! [Sec] Mode : Off
250 Dev_ref_sec=0 ! Ref.Value: 0
260 Page_no=4 ! Meas. Setting Page Number : 4
270 !
280 I_mon$="OFF" ! Test Signal Current : Off
290 V_mon$="ON" ! Level Monitor Voltage : On
300 Beep_mode$="FAIL" ! Beep mode : Fail
310 Save_no=9 ! Save Location Number : 9
320 !
330 OUTPUT @Agt4288a;" :SYST:PRES"
340 OUTPUT @Agt4288a;" :CALC1:FORM "&Pri$
350 OUTPUT @Agt4288a;" :CALC2:FORM "&Sec$

```

Setting Up Measurement Conditions and Display Sample Program

```
360 OUTPUT @Agt4288a;":SOUR:FREQ ";Freq
370 OUTPUT @Agt4288a;":SOUR:VOLT ";Level
380 IF Range$="AUTO" THEN
390     OUTPUT @Agt4288a;":RANG:AUTO ON"
400 ELSE
410     OUTPUT @Agt4288a;":RANG:AUTO OFF"
420     OUTPUT @Agt4288a;":RANG "&Range$
430 END IF
440 OUTPUT @Agt4288a;":APER "&Meas_time$
450 OUTPUT @Agt4288a;":CAL:CABL ";Cable
460 OUTPUT @Agt4288a;":AVER ON"
470 OUTPUT @Agt4288a;":AVER:COUN ";Ave
480 OUTPUT @Agt4288a;":TRIG:DEL ";Delay
490 !
500 OUTPUT @Agt4288a;":DISP "&Disp$
510 OUTPUT @Agt4288a;":DISP:TEXT1:DIG ";Digit
520 IF Fix_msd$="OFF" THEN
530     OUTPUT @Agt4288a;":DISP:TEXT1:FMSD OFF"
540 ELSE
550     OUTPUT @Agt4288a;":DISP:TEXT1:FMSD ON"
560     OUTPUT @Agt4288a;":DISP:TEXT1:FMSD:DATA "&Fix_msd$
570 END IF
580 IF Dev_mode_pri$="OFF" THEN
590     OUTPUT @Agt4288a;":CALC1:MATH:STAT OFF"
600 ELSE
610     OUTPUT @Agt4288a;":CALC1:MATH:STAT ON"
620     OUTPUT @Agt4288a;":CALC1:MATH:EXPR:NAME "&Dev_mode_pri$
630     OUTPUT @Agt4288a;":DATA REF1,";Dev_ref_pri
640 END IF
650 IF Dev_mode_sec$="OFF" THEN
660     OUTPUT @Agt4288a;":CALC2:MATH:STAT OFF"
670 ELSE
680     OUTPUT @Agt4288a;":CALC2:MATH:STAT ON"
690     OUTPUT @Agt4288a;":CALC2:MATH:EXPR:NAME "&Dev_mode_sec$
700     OUTPUT @Agt4288a;":DATA REF2,";Dev_ref_sec
710 END IF
720 OUTPUT @Agt4288a;":DISP:TEXT2:PAGE ";Page_no
730 !
740 OUTPUT @Agt4288a;":CALC3:MATH:STAT "&I_mon$
750 OUTPUT @Agt4288a;":CALC4:MATH:STAT "&V_mon$
760 IF Beep_mode$="OFF" THEN
770     OUTPUT @Agt4288a;":CALC:COMP:BEEP OFF"
780 ELSE
790     OUTPUT @Agt4288a;":CALC:COMP:BEEP ON"
800     OUTPUT @Agt4288a;":CALC:COMP:BEEP:COND "&Beep_mode$
810 END IF
820 !
830 OUTPUT @Agt4288a;":*SAV ";Save_no
840 !
850 END
```

4 Preparation for Accurate Measurement (Executing Compensation)

This chapter describes how to execute the compensation function.

Executing OPEN/SHORT/LOAD Compensation

Turning ON/OFF compensation function

To turn ON/OFF each type of compensation, use the corresponding command below.

Type of compensation	Command
OPEN compensation	:CORR:OPEN on page 165
SHORT compensation	:CORR:SHOR on page 165
LOAD compensation	:CORR:LOAD on page 160

Executing the measurement of compensation data with the **:CORR:COLL** command on page 157 automatically measures data and turns ON the compensation.

Measuring compensation data

Measuring compensation data

To measure each type of compensation data, use the following command.

- **:CORR:COLL** on page 157

When you execute the above command, measurement is performed only for the frequency specified at execution time. The result is stored as the data for normal operation when the multi-compensation function is OFF and as the data for multi-compensation when it is ON (for the channel that has been selected at execution).

Settings for the cable length and the frequency shift (for 1 MHz) during measurement are stored together with the obtained result.

The compensation data is measured under the following measurement conditions:

- The auto range mode is used during measurement.
- The measurement time is measured in the long mode.
- The low C reject function is OFF during measurement.
- The output impedance of the measurement signal source is set to 20 Ω independent of the used measurement range when the SHORT compensation data is measured.

For other settings, the conditions set up at execution are used for the measurement.

Defining LOAD compensation standard

Before measuring LOAD compensation data, you must define the LOAD compensation standard. To define the LOAD compensation standard, use the following commands.

- **:CORR:CKIT:STAN3** on page 155
- **:CORR:CKIT:STAN3:FORM** on page 156

Reading/writing compensation data (saving/recalling compensation conditions)

After saving the compensation conditions to a file, you can recall these conditions on the 4288A at any time from the file.

The compensation data is set up in the parameter-oriented format shown in the table below:

Type of compensation	Parameter format
OPEN compensation	G-B or Cp-G (select with the :CORR:CKIT:STAN1:FORM command)
SHORT compensation	R-X or Ls-Rs (select with the :CORR:CKIT:STAN2:FORM command)
LOAD compensation	Parameter format to define the LOAD compensation standard (select with the :CORR:CKIT:STAN3:FORM command)

To read/write the compensation data, use the following command.

- **:CORR:DATA** on page 158

The compensation data written using the above command is handled as follows:

- Saved as the compensation data for the measurement frequency specified when the command is executed.
- Saved as the data for normal operation when the multi-compensation function is OFF and as the data for the multi-compensation when it is ON (for the channel that has been selected at execution).

NOTE

When you write compensation data, note the following:

- Before writing, recall the settings of the measurement frequency, cable length, and frequency shift (for 1 MHz) specified when the data was read.
- For the LOAD compensation data, in addition to the above, you also need to recall the settings of the LOAD compensation standard (definition value and parameter type) specified when the data was read.
- Turn ON the compensation function. (Unlike when measuring the compensation data, writing the compensation data does not automatically turn this function ON.)

Avoiding work-related mistakes in measuring compensation data

To avoid simple mistakes related to work when measuring compensation data (for example, setting up the OPEN state and SHORT state inversely), it is important to confirm that the measured data has a proper value.

If a measured value is not proper during measurement of the compensation data, a warning message appears on the display. However, the occurrence of a warning message cannot be detected through GPIB. Therefore, to detect erroneous compensation data through GPIB, you need to read out the compensation data after each measurement and then confirm that the value is appropriate.

Sample program

Example 4-1 shows a sample program to execute the OPEN/SHORT/LOAD compensation. Example 4-2 shows a sample program to read out and recall compensation data saved in a file. These programs are stored on the sample program disk under the filenames “compen.bas” and “comp_dat.bas.”

Example 4-1 executes the OPEN/SHORT/LOAD compensation and then saves the compensation state (each compensation data item, LOAD compensation standard definition value, cable length, and frequency shift) into a file.

The program details of Example 4-1 are described below.

Line 50	Sets the GPIB address.
Line 70	Assigns the filename for saving the compensation state (Cmp_data) to the File_name\$ variable.
Line 90	Resets the instrument.
Lines 110 to 160	Uses the FNCompen sub-program to execute the OPEN/SHORT/LOAD compensation.
Line 180	Uses the Save_comp_data sub-program to save the compensation state to a file whose name is File_name\$.

The FNCompen sub-program of Lines 210 to 1150 used to execute the compensation is described below.

Lines 290 to 300	Reads out the setup of the current measurement frequency and sets it to the Curr_freq variable.
Lines 310 to 320	Sets the measurement frequencies (1 kHz and 1 MHz) in the Freq array.
Line 330	Assigns the LOAD compensation standard definition parameter (Cp-D) to the Load_para\$ variable.
Lines 340 to 350	Makes the setup generate SRQ when measurement of compensation data is finished.
Line 380	If the value of Standard\$ is “Open,” assigns the parameter (STAN1) used at the execution of the compensation data measurement command to the Std\$ variable.
Line 400	If the value of Standard\$ is “Short,” assigns the parameter (STAN2) used at the execution of the compensation data measurement command to the Std\$ variable.
Lines 420 to 510	If the value of Standard\$ is “Load,” assigns the parameter (STAN3) used at the execution of the compensation data measurement command to the Std\$ variable. Then, for both 1 kHz and 1 MHz, obtains and sets up the LOAD compensation standard definition value (Cp, D) using the Inp_data sub-program by user entry.
Lines 540 to 550	Prompts the user to make the connection for the compensation specified with Standard\$. After the connection, waits for the user to enter the y key and Enter key.
Lines 570 to 1060	Repeats the following twice (for 1 kHz and 1 MHz). <ol style="list-style-type: none">1. Lines 580 to 590: Displays the measurement frequency and sets

Preparation for Accurate Measurement (Executing Compensation) Executing OPEN/SHORT/LOAD Compensation

the measurement frequency to Freq.

2. Lines 600 to 620: Clears the status byte register, operation status event register, and error queue.
3. Lines 640 to 650: Sets the branch destination of the SRQ interrupt and enables the SRQ interrupt.
4. Lines 660 to 670: Executes the compensation data measurement command and waits for the completion of the measurement.
5. Reads out the compensation data and assigns its values to the Para1 and Para2 variables, respectively.
6. Line 790: Sets the Err_flag variable to 0.
7. Lines 820 to 840: If the value of Standard\$ is “Open,” calculates the absolute value of the admittance from the Para1 and Para2 values. If the value is equal to or greater than Limit, sets Err_flag to 1 again.
8. Lines 860 to 880: If the value of Standard\$ is “Short,” calculates the absolute value of the impedance from the Para1 and Para2 values. If the value is equal to or greater than Limit, sets Err_flag to 1 again.
9. Lines 900 to 1000: If the value of Standard\$ is “Load”, reads out the LOAD compensation standard definition value, calculates the absolute value of the impedance of the LOAD compensation standard from the value, and assigns the result to the Zref variable. Then calculates the absolute value of the impedance from the Para1 and Para2 values. If the absolute value of the difference between the value and Zref is equal to or greater than Limit, sets Err_flag to 1 again.
10. Lines 1020 to 1050: If the value of Err_flag is 1, displays the out-of-limit-range message and returns to Line 530.

Lines 1070 to 1090 Displays the end-of-measurement message and sets the measurement frequency to Curr_freq and then returns 0 as the return value from the sub-program.

Lines 1110 to 1130 This is the processing when a key other than the y key is pressed in Line 550. Returns -1 as the return value from the sub-program.

The Save_comp_data sub-program of Lines 1160 to 1530 used to save the compensation data is described below.

Lines 1240 to 1270 Reads out the setups of the cable length and frequency shift and sets them to the Cable and F_shift variables, respectively.

Lines 1290 to 1410 Reads out the OPEN compensation data, SHORT compensation data, LOAD compensation data, and LOAD compensation standard definition value for both 1 kHz and 1 MHz and stores them to the Open, Shor, Load, and Load_ref arrays.

Lines 1420 to 1430 Reads out the setup of the LOAD compensation standard definition parameter and assigns it into the Load_para\$ variable.

Lines 1450 to 1470 If there is a file whose name is File_name\$, deletes it.

Lines 1480 to 1510 Creates a file naming it File_name\$ and writes the data stored in

Preparation for Accurate Measurement (Executing Compensation)

Executing OPEN/SHORT/LOAD Compensation

- Cable, F_shift, Open, Shor, Load, Load_ref, and Load_para\$ to the file.
- Line 1520 Displays the name of the file to which the compensation state is saved.
- The Inp_data sub-program of Lines 1540 to 1680 used to input data is described below.
- Line 1590 Makes the setup to return to the entry start line when an error (for example, due to improper input) occurs so that the user can make the entry again.
- Lines 1610 to 1620 Prompts the user to enter the data value specified with Mes\$ and waits for the user to enter the value.
- Lines 1630 to 1650 Displays the entered value and waits for the user to enter yes or no (the y/n key).
- Line 1660 If a key other than the y key is pressed in Line 1650, returns to the entry start line (Line 1610).

Example 4-1

Executing the OPEN/SHORT/LOAD compensation (compen.bas)

```
10   DIM File_name$(20)
20   INTEGER Result
30   CLEAR SCREEN
40   !
50   ASSIGN @Agt4288a TO 717
60   !
70   File_name$="Cmp_data"
80   !
90   OUTPUT @Agt4288a;" :SYST:PRES"
100  !
110  Result=FNCompen(@Agt4288a,"Open",.00002)
120  IF Result<>0 THEN Prog_end
130  Result=FNCompen(@Agt4288a,"Short",20)
140  IF Result<>0 THEN Prog_end
150  Result=FNCompen(@Agt4288a,"Load",.2)
160  IF Result<>0 THEN Prog_end
170  !
180  CALL Save_comp_data(@Agt4288a,File_name$)
190  !
200 Prog_end:  END
210  !=====
220  ! Compensation Data Measurement Function
230  !=====
240  DEF FNCompen(@Agt4288a,Standard$,Limit)
250  DIM Inp_char$(9),Buff$(9),Std$(9),Err$(50)
260  REAL Curr_freq,Freq(1:2),Para1,Para2,Zm,Ym,Gm,Bm
270  REAL Cpref,Dref,Zref,Gref,Bref
280  INTEGER Err_flag
290  OUTPUT @Agt4288a;" :SOUR:FREQ?"
300  ENTER @Agt4288a;Curr_freq
310  Freq(1)=1.E+3
320  Freq(2)=1.E+6
330  Load_para$="CPD"
340  OUTPUT @Agt4288a;" :STAT:OPER:ENAB 128"
350  OUTPUT @Agt4288a;" *SRE 128"
360  SELECT Standard$
370     CASE "Open"
380         Std$="STAN1"
```

Preparation for Accurate Measurement (Executing Compensation)
Executing OPEN/SHORT/LOAD Compensation

```

390     CASE "Short"
400         Std$="STAN2"
410     CASE "Load"
420         Std$="STAN3"
430         CALL Inp_data("Load(Cp) Value @1kHz",Load1(1))
440         CALL Inp_data("Load(D) Value @1kHz",Load2(1))
450         CALL Inp_data("Load(Cp) Value @1MHz",Load1(2))
460         CALL Inp_data("Load(D) Value @1MHz",Load2(2))
470         OUTPUT @Agt4288a;":CORR:CKIT:STAN3:FORM "&Load_para$
480         FOR I=1 TO 2
490             OUTPUT @Agt4288a;":SOUR:FREQ ";Freq(I)
500             OUTPUT @Agt4288a;":CORR:CKIT:STAN3 ";Load1(I);",";Load2(I)
510         NEXT I
520     END SELECT
530 Compen_meas: !
540     PRINT "Set "&Standard$&"-Connection."
550     INPUT "OK? [Y/N]",Inp_char$
560     IF UPC$(Inp_char$)="Y" THEN
570         FOR I=1 TO 2
580             PRINT "Frequency: ";Freq(I)
590             OUTPUT @Agt4288a;":SOUR:FREQ ";Freq(I)
600             OUTPUT @Agt4288a;"*CLS"
610             OUTPUT @Agt4288a;"*OPC?"
620             ENTER @Agt4288a;Buff$
630             ! Measurement
640             ON INTR 7 GOTO Meas_end
650             ENABLE INTR 7;2
660             OUTPUT @Agt4288a;":CORR:COLL "&Std$
670 Meas_wait: GOTO Meas_wait
680 Meas_end: OFF INTR 7
690             ! Error Check
700             OUTPUT @Agt4288a;":SYST:ERR?"
710             ENTER @Agt4288a;Err_no,Err$
720             IF Err_no<>0 THEN
730                 PRINT "Error: "&Err$
740                 GOTO Compen_meas
750             END IF
760             ! Data Check
770             OUTPUT @Agt4288a;":CORR:DATA? "&Std$
780             ENTER @Agt4288a;Paral,Para2
790             Err_flag=0
800             SELECT Standard$
810                 CASE "Open"
820                     Ym=SQRT(Paral*Paral+Para2*Para2)
830                     PRINT "G =" ;Paral,"B =" ;Para2,"|Y| =" ;Ym
840                     IF Ym>=Limit THEN Err_flag=1
850                 CASE "Short"
860                     Zm=SQRT(Paral*Paral+Para2*Para2)
870                     PRINT "R =" ;Paral,"X =" ;Para2,"|Z| =" ;Zm
880                     IF Zm>=Limit THEN Err_flag=1
890                 CASE "Load"
900                     OUTPUT @Agt4288a;":CORR:CKIT:STAN3?"
910                     ENTER @Agt4288a;Cpref,Dref
920                     Bref=2*PI*Freq(I)*Cpref
930                     Gref=Bref*Dref
940                     Zref=1/SQRT(Gref*Gref+Bref*Bref)
950                     Bm=2*PI*Freq(I)*Paral
960                     Gm=Bm*Para2
970                     Zm=1/SQRT(Gm*Gm+Bm*Bm)
980                     PRINT "Cpref=" ;Cpref,"Dref=" ;Dref,"|Zref| =" ;Zref
990                     PRINT "Cp =" ;Paral,"D =" ;Para2,"|Z| =" ;Zm
1000                    IF ABS((Zm-Zref)/Zref)>=Limit THEN Err_flag=1
1010                END SELECT
1020             IF Err_flag<>0 THEN

```

Preparation for Accurate Measurement (Executing Compensation) Executing OPEN/SHORT/LOAD Compensation

```
1030         PRINT "Out of limit!!"
1040         GOTO Compen_meas
1050     END IF
1060     NEXT I
1070     PRINT Standard$&" Data Measurement Complete"
1080     OUTPUT @Agt4288a;" :SOUR:FREQ ";Curr_freq
1090     RETURN 0
1100 ELSE
1110     PRINT "Program Interruption"
1120     OUTPUT @Agt4288a;" :SOUR:FREQ ";Curr_freq
1130     RETURN -1
1140 END IF
1150 FNEND
1160 !=====
1170 ! Compensation Data File Save Function
1180 !=====
1190 SUB Save_comp_data(@Agt4288a,File_name$)
1200     DIM Load_para$(5)
1210     REAL Freq(1:2),Open(1:2,1:2),Shor(1:2,1:2)
1220     REAL Load(1:2,1:2),Load_ref(1:2,1:2)
1230     INTEGER Cable,F_shift,Fr,Std
1240     OUTPUT @Agt4288a;" :CAL:CABL?"
1250     ENTER @Agt4288a;Cable
1260     OUTPUT @Agt4288a;" :SYST:FSH?"
1270     ENTER @Agt4288a;F_shift
1280     !
1290     Freq(1)=1.E+3
1300     Freq(2)=1.E+6
1310     FOR Fr=1 TO 2
1320         OUTPUT @Agt4288a;" :SOUR:FREQ ";Freq(Fr)
1330         OUTPUT @Agt4288a;" :CORR:DATA? STAN1"
1340         ENTER @Agt4288a;Open(Fr,1),Open(Fr,2)
1350         OUTPUT @Agt4288a;" :CORR:DATA? STAN2"
1360         ENTER @Agt4288a;Shor(Fr,1),Shor(Fr,2)
1370         OUTPUT @Agt4288a;" :CORR:DATA? STAN3"
1380         ENTER @Agt4288a;Load(Fr,1),Load(Fr,2)
1390         OUTPUT @Agt4288a;" :CORR:CKIT:STAN3?"
1400         ENTER @Agt4288a;Load_ref(Fr,1),Load_ref(Fr,2)
1410     NEXT Fr
1420     OUTPUT @Agt4288a;" :CORR:CKIT:STAN3:FORM?"
1430     ENTER @Agt4288a;Load_para$
1440     !
1450     ON ERROR GOTO Skip_purge
1460     PURGE File_name$
1470 Skip_purge: OFF ERROR
1480     CREATE File_name$,1
1490     ASSIGN @File TO File_name$
1500     OUTPUT @File;Cable,F_shift,Open(*),Shor(*),Load(*),Load_ref(*),Lo
ad_para$
1510     ASSIGN @File TO *
1520     PRINT "Save file name: "&File_name$
1530 SUBEND
1540 !=====
1550 ! Data Input Function
1560 !=====
1570 SUB Inp_data(Mes$,Inp_val)
1580     DIM Inp_char$(30)
1590     ON ERROR GOTO Inp_start
1600 Inp_start: !
1610     PRINT "Input "&Mes$
1620     INPUT "Value?",Inp_char$
1630     Inp_val=VAL(UPC$(Inp_char$))
1640     PRINT "Input Value: ";Inp_val
1650     INPUT "OK? [Y/N]",Inp_char$
```

Preparation for Accurate Measurement (Executing Compensation) Executing OPEN/SHORT/LOAD Compensation

```
1660 IF UPC$(Inp_char$)<>"Y" THEN Inp_start
1670 OFF ERROR
1680 SUBEND
```

Example 4-2 reads out data saved into a file by the program of Example 4-1 and recovers the compensation state at the execution of Example 4-1.

The program of Example 4-2 is detailed below:

- Line 70 Sets the GPIB address.
- Line 90 Assings the filename from which the compensation state data is read out (Cmp_data) to the File_name\$ variable.
- Line 120 Specifies the branch destination if an error occurs (for example, there is no file whose name is File_name\$) when reading out the data from the file.
- Lines 130 to 150 Reads out the cable length, frequency shift, OPEN compensation data, SHORT compensation data, LOAD compensation data, LOAD compensation standard definition value, and LOAD compensation standard definition parameter from the File_name\$ file and stores them as the Cable, F_shift, Open, Shor, Load, Load_ref, and Load_para\$ variables, respectively.
- Lines 180 to 230 Sets the cable length, frequency shift, and compensation standard definition parameter to Cable, F_shift, and Load_para\$, respectively, and displays the setups.
- Lines 250 to 390 For both 1 kHz and 1 MHz, sets the OPEN compensation data, SHORT compensation data, LOAD compensation data, and LOAD compensation standard definition value to Open, Short, Load, and Load_ref, respectively, and displays the settings.
- Lines 410 to 430 Turns ON the OPEN/SHORT/LOAD compensations individually.
- Lines 460 to 500 The processing done if an error occurs while reading out the data from the file.

Preparation for Accurate Measurement (Executing Compensation) Executing OPEN/SHORT/LOAD Compensation

Example 4-2

Recovering the compensation state (comp_dat.bas)

```
10 DIM File_name$(20),Load_para$(5),Img$(30)
20 REAL Freq(1:2),Open(1:2,1:2),Shor(1:2,1:2)
30 REAL Load(1:2,1:2),Load_ref(1:2,1:2)
40 INTEGER Cable,F_shift,Fr
50 CLEAR SCREEN
60 !
70 ASSIGN @Agt4288a TO 717
80 !
90 File_name$="Cmp_data"
100 !
110 PRINT "[Download Compensation data]"
120 ON ERROR GOTO File_error
130 ASSIGN @File TO File_name$;FORMAT OFF
140 ENTER @File;Cable,F_shift,Open(*),Shor(*),Load(*),Load_ref(*),Loa
d_para$
150 ASSIGN @File TO *
160 OFF ERROR
170 !
180 OUTPUT @Agt4288a;":CAL:CABL ";Cable
190 OUTPUT @Agt4288a;":SYST:FSH ";F_shift
200 OUTPUT @Agt4288a;":CORR:CKIT:STAN3:FORM "&Load_para$
210 PRINT "Cable      ";Cable;"m"
220 PRINT "1MHz Shift:";F_shift;"%"
230 PRINT "Load para  : ";Load_para$
240 !
250 Freq(1)=1.E+3
260 Freq(2)=1.E+6
270 FOR Fr=1 TO 2
280   OUTPUT @Agt4288a;":SOUR:FREQ ";Freq(Fr)
290   OUTPUT @Agt4288a;":CORR:DATA STAN1,";Open(Fr,1);",";Open(Fr,2)
300   OUTPUT @Agt4288a;":CORR:DATA STAN2,";Shor(Fr,1);",";Shor(Fr,2)
310   OUTPUT @Agt4288a;":CORR:DATA STAN3,";Load(Fr,1);",";Load(Fr,2)
320   OUTPUT @Agt4288a;":CORR:CKIT:STAN3";Load_ref(Fr,1);",";Load_ref
(Fr,2)
330   Img$="7A,MD.5DE,3X,MD.5DE"
340   PRINT "Frequency  :";Freq(Fr);"Hz"
350   PRINT USING Img$;"Open  : ",Open(Fr,1),Open(Fr,2)
360   PRINT USING Img$;"Short: ",Shor(Fr,1),Shor(Fr,2)
370   PRINT USING Img$;"Load  : ",Load(Fr,1),Load(Fr,2)
380   PRINT USING Img$;" Ref  : ",Load_ref(Fr,1),Load_ref(Fr,2)
390 NEXT Fr
400 !
410 OUTPUT @Agt4288a;":CORR:OPEN ON"
420 OUTPUT @Agt4288a;":CORR:SHOR ON"
430 OUTPUT @Agt4288a;":CORR:LOAD ON"
440 !
450 GOTO Prog_end
460 File_error: OFF ERROR
470 PRINT "##### ERROR #####"
480 PRINT "The CAL_DATA (cal. coef. file) is NOT exist."
490 PRINT "                or"
500 PRINT "The CAL_DATA's size is UNSUITABLE."
510 !
520 Prog_end: END
```

Executing Offset Compensation

Turning ON/OFF the compensation function

When you turn ON the offset compensation, assuming that the measured value before compensation is $Meas$ and the offset compensation data is $Offset$, the measured value is compensated as $Meas - Offset$.

To turn ON/OFF the offset compensation, use the following command.

- **:CORR:OFFS** on page 163

You cannot turn ON/OFF the primary parameter and secondary parameter separately. However, if you set the compensation value to 0, the state is actually the same as OFF even if the offset compensation is ON. Therefore, in practice you can realize separate ON/OFF states by setting the compensation value for either parameter to 0.

Setting up the compensation data

To set up the offset compensation data, use the following command.

- **:CORR:OFFS:DATA** on page 164

The entered value is set as the offset compensation data for the measurement frequency at the time of the entry.

Using the Multi-compensation Function

Turning ON/OFF the multi-compensation function

To turn ON/OFF the multi-compensation function, use the following command.

- **:CORR:MULT** on page 161

Selecting a channel

To select a channel for the multi compensation function, use the following command.

- **:CORR:MULT:CHAN** on page 161

Measuring compensation data

Selecting the definition method of the LOAD compensation standard

To select whether to define the LOAD compensation standard value (LOAD compensation reference value) for each channel individually or for all channels commonly, use the following command.

- **:CORR:MULT:CKIT:STAN3** on page 162

Measuring compensation data

The method to measure the OPEN/SHORT/LOAD compensation data for multi-compensation is the same as that for basic compensation data except that you need to select the proper channel before measurement. For more details, refer to “Measuring compensation data” on page 36.

Reading/writing compensation data

The method used to read/write the OPEN/SHORT/LOAD compensation data for multi-compensation is the same as that for basic compensation data except that you need to select the proper channel before measurement. For more details, refer to “Reading/writing compensation data (saving/recalling compensation conditions)” on page 37.

Sample program

Example 4-3 shows a sample program to execute multi-compensation. This program is stored on the sample program disk under the filename “multi.bas.”

This program defines a different LOAD compensation standard value for each channel and executes the OPEN/SHORT/LOAD compensation for four channels (0 to 3).

The program is detailed below.

- | | |
|------------------|--|
| Line 40 | Sets the GPIB address. |
| Line 60 | Performs a reset. |
| Lines 70 to 80 | Turns ON the multi-compensation function and then selects the channel-by-channel definition for the LOAD compensation standard value. |
| Line 90 | Makes the setup display the multi-compensation function setup in the instrument setup display area. |
| Lines 110 to 160 | Repeats the following four times (channels: 0 to 3). <ol style="list-style-type: none">1. Line 120: Displays the channel.2. Line 130: Sets up the channel of the 4288A.3. Line 140: Uses the FNCompen sub-program to execute the OPEN compensation. For information on the FNCompen sub-program, refer to the description in Example 4-1 on page 40. |
| Lines 170 to 220 | Repeats the following four times (channels: 0 to 3). <ol style="list-style-type: none">1. Line 180: Displays the channel.2. Line 190: Sets up the channel of the 4288A.3. Line 200: Uses the FNCompen sub-program to execute the SHORT compensation. |
| Lines 230 to 280 | Repeats the following four times (channels: 0 to 3). <ol style="list-style-type: none">1. Line 240: Displays the channel.2. Line 250: 4288A Sets up the channel of the 4288A.3. Line 260: Uses the FNCompen sub-program to execute the LOAD compensation. |

Preparation for Accurate Measurement (Executing Compensation) Using the Multi-compensation Function

Example 4-3

Executing the multi compensation (multi.bas)

```
10     INTEGER Ch,Result
20     CLEAR SCREEN
30     !
40     ASSIGN @Agt4288a TO 717
50     !
60     OUTPUT @Agt4288a;" :SYST:PRES"
70     OUTPUT @Agt4288a;" :CORR:MULT ON"
80     OUTPUT @Agt4288a;" :CORR:MULT:CKIT:STAN3 ON"
90     OUTPUT @Agt4288a;" :DISP:TEXT2:PAGE 5"
100    !
110   FOR Ch=0 TO 3
120     PRINT "## Channel No. : ";Ch;"##"
130     OUTPUT @Agt4288a;" :CORR:MULT:CHAN ";Ch
140     Result=FNCompen(@Agt4288a,"Open",.00002)
150     IF Result<>0 THEN Prog_end
160   NEXT Ch
170   FOR Ch=0 TO 3
180     PRINT "## Channel No. : ";Ch;"##"
190     OUTPUT @Agt4288a;" :CORR:MULT:CHAN ";Ch
200     Result=FNCompen(@Agt4288a,"Short",20)
210     IF Result<>0 THEN Prog_end
220   NEXT Ch
230   FOR Ch=0 TO 3
240     PRINT "## Channel No. : ";Ch;"##"
250     OUTPUT @Agt4288a;" :CORR:MULT:CHAN ";Ch
260     Result=FNCompen(@Agt4288a,"Load",.2)
270     IF Result<>0 THEN Prog_end
280   NEXT Ch
290   !
300 Prog_end:  END
310   !=====
320   ! Compensation Data Measurement Function
330   !=====
340 DEF FNCompen(@Agt4288a,Standard$,Limit)
350 DIM Inp_char$(9),Buff$(9),Std$(9),Err$(50)
360 REAL Curr_freq,Freq(1:2),Para1,Para2,Zm,Ym,Gm,Bm
370 REAL Cpref,Dref,Zref,Gref,Bref
380 INTEGER Err_flag
390 OUTPUT @Agt4288a;" :SOUR:FREQ?"
400 ENTER @Agt4288a;Curr_freq
410 Freq(1)=1.E+3
420 Freq(2)=1.E+6
430 Load_para$="CPD"
440 OUTPUT @Agt4288a;" :STAT:OPER:ENAB 128"
450 OUTPUT @Agt4288a;" *SRE 128"
460 SELECT Standard$
470   CASE "Open"
480     Std$="STAN1"
490   CASE "Short"
500     Std$="STAN2"
510   CASE "Load"
520     Std$="STAN3"
530   CALL Inp_data("Load(Cp) Value @1kHz",Load1(1))
540   CALL Inp_data("Load(D) Value @1kHz",Load2(1))
550   CALL Inp_data("Load(Cp) Value @1MHz",Load1(2))
560   CALL Inp_data("Load(D) Value @1MHz",Load2(2))
570   OUTPUT @Agt4288a;" :CORR:CKIT:STAN3:FORM "&Load_para$
580   FOR I=1 TO 2
590     OUTPUT @Agt4288a;" :SOUR:FREQ ";Freq(I)
600     OUTPUT @Agt4288a;" :CORR:CKIT:STAN3 ";Load1(I);",";Load2(I)
610   NEXT I
```

Preparation for Accurate Measurement (Executing Compensation) Using the Multi-compensation Function

```

620     END SELECT
630 Compen_meas:  !
640     PRINT "Set "&Standard$&"-Connection."
650     INPUT "OK? [Y/N]", Inp_char$
660     IF UPC$(Inp_char$)="Y" THEN
670         FOR I=1 TO 2
680             PRINT "Frequency:";Freq(I)
690             OUTPUT @Agt4288a;":SOUR:FREQ ";Freq(I)
700             OUTPUT @Agt4288a;"*CLS"
710             OUTPUT @Agt4288a;"*OPC?"
720             ENTER @Agt4288a;Buff$
730             ! Measurement
740             ON INTR 7 GOTO Meas_end
750             ENABLE INTR 7;2
760             OUTPUT @Agt4288a;":CORR:COLL "&Std$
770 Meas_wait:  GOTO Meas_wait
780 Meas_end:  OFF INTR 7
790             ! Error Check
800             OUTPUT @Agt4288a;":SYST:ERR?"
810             ENTER @Agt4288a;Err_no,Err$
820             IF Err_no<>0 THEN
830                 PRINT "Error: "&Err$
840                 GOTO Compen_meas
850             END IF
860             ! Data Check
870             OUTPUT @Agt4288a;":CORR:DATA? "&Std$
880             ENTER @Agt4288a;Para1,Para2
890             Err_flag=0
900             SELECT Standard$
910                 CASE "Open"
920                     Ym=SQRT(Para1*Para1+Para2*Para2)
930                     PRINT "G =" ;Para1,"B =" ;Para2,"|Y| =" ;Ym
940                     IF Ym>=Limit THEN Err_flag=1
950                 CASE "Short"
960                     Zm=SQRT(Para1*Para1+Para2*Para2)
970                     PRINT "R =" ;Para1,"X =" ;Para2,"|Z| =" ;Zm
980                     IF Zm>=Limit THEN Err_flag=1
990                 CASE "Load"
1000                    OUTPUT @Agt4288a;":CORR:CKIT:STAN3?"
1010                    ENTER @Agt4288a;Cpref,Dref
1020                    Bref=2*PI*Freq(I)*Cpref
1030                    Gref=Bref*Dref
1040                    Zref=1/SQRT(Gref*Gref+Bref*Bref)
1050                    Bm=2*PI*Freq(I)*Para1
1060                    Gm=Bm*Para2
1070                    Zm=1/SQRT(Gm*Gm+Bm*Bm)
1080                    PRINT "Cpref=" ;Cpref,"Dref=" ;Dref,"|Zref| =" ;Zref
1090                    PRINT "Cp =" ;Para1,"D =" ;Para2,"|Z| =" ;Zm
1100                    IF ABS((Zm-Zref)/Zref)>=Limit THEN Err_flag=1
1110             END SELECT
1120             IF Err_flag<>0 THEN
1130                 PRINT "Out of limit!!"
1140                 GOTO Compen_meas
1150             END IF
1160         NEXT I
1170         PRINT Standard$&" Data Measurement Complete"
1180         OUTPUT @Agt4288a;":SOUR:FREQ ";Curr_freq
1190         RETURN 0
1200     ELSE
1210         PRINT "Program Interruption"
1220         OUTPUT @Agt4288a;":SOUR:FREQ ";Curr_freq
1230         RETURN -1
1240     END IF
1250 FNEND

```

Preparation for Accurate Measurement (Executing Compensation) Using the Multi-compensation Function

```
1260 !=====
1270 ! Data Input Function
1280 !=====
1290 SUB Inp_data(Mes$,Inp_val)
1300 DIM Inp_char$(30)
1310 ON ERROR GOTO Inp_start
1320 Inp_start:
1330 PRINT "Input "&Mes$
1340 INPUT "Value?",Inp_char$
1350 Inp_val=VAL(UPC$(Inp_char$))
1360 PRINT "Input Value: ";Inp_val
1370 INPUT "OK? [Y/N]",Inp_char$
1380 IF UPC$(Inp_char$)<>"Y" THEN Inp_start
1390 OFF ERROR
1400 SUBEND
```

5

Starting (Triggering) Measurement and Waiting for Completion of Measurement

This chapter describes how to trigger the instrument to start measurement and how to detect completion of measurement.

Starting (triggering) Measurement

Trigger system

The operations performed by the trigger system include detection of the measurement start signal (trigger) and control of the delay time for starting measurement. The trigger system has three states: “idle,” “waiting for trigger,” and “measurement,” as shown in Figure 5-1.

Figure 5-1

Trigger system

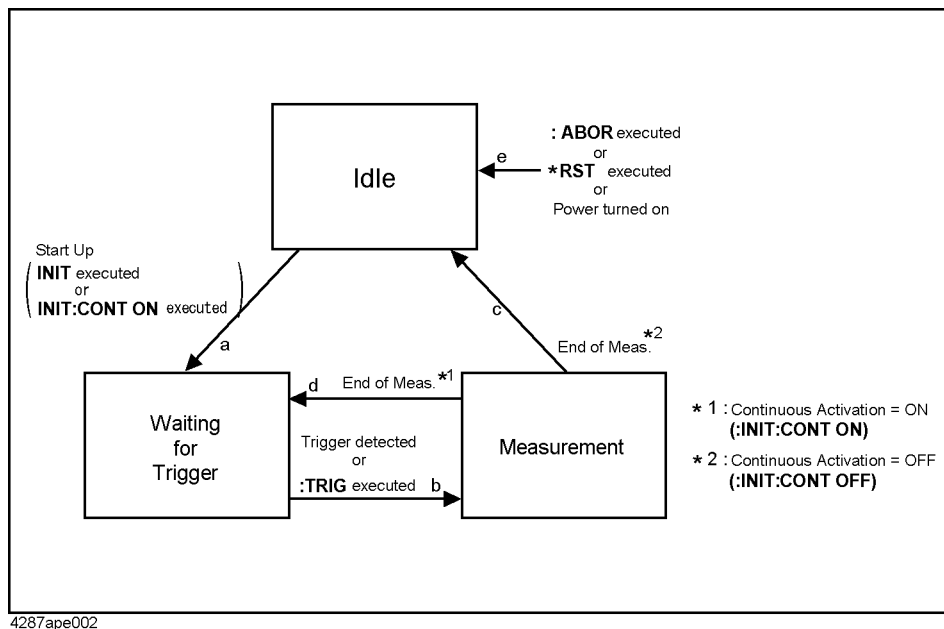

Each state of the trigger system and the transitions between them are described below.

Idle state

When the following commands are executed, the trigger system transitions to the idle state (e in Figure 5-1). The idle state is also in effect immediately after power-on. Because the continuous activation of the trigger system and the trigger mode are set to ON and internal trigger, respectively, at power-on, the trigger system immediately transitions to the waiting for trigger state and then repeats the transition between the measurement state and the waiting for trigger state.

- ***RST** on page 126
- **:ABOR** on page 130

When the trigger system is started up using the following commands, it transitions to the waiting for trigger state (a in Figure 5-1).

- **:INIT** on page 183
- **:INIT:CONT** on page 183 (when executed with ON specified)

Waiting for trigger state (trigger event detect state)

The waiting for trigger state, when the instrument is triggered (a trigger is detected) or the **:TRIG** command on page 195 is executed, transitions to the measurement state after the trigger delay time (set with the **:TRIG:DEL** command on page 195) has elapsed (b in Figure 5-1).

As shown in the table below, the instrument triggering method differs depending on which trigger mode is set. To set up the trigger mode, use the **:TRIG:SOUR** command on page 196.

Trigger mode	Instrument triggering method
Internal trigger (Int)	The instrument is automatically triggered within itself.
External trigger (Ext)	The instrument is triggered when a trigger signal is input through the Ext Trig terminal or the handler/scanner interface.
GPIB trigger (Bus)	The instrument is triggered when the *TRG command on page 128 is executed.
Manual trigger (Man)	The instrument is triggered when the [Trig] key on the front panel is pressed.

Figure 5-2

Transition flow from waiting for trigger state to measurement state

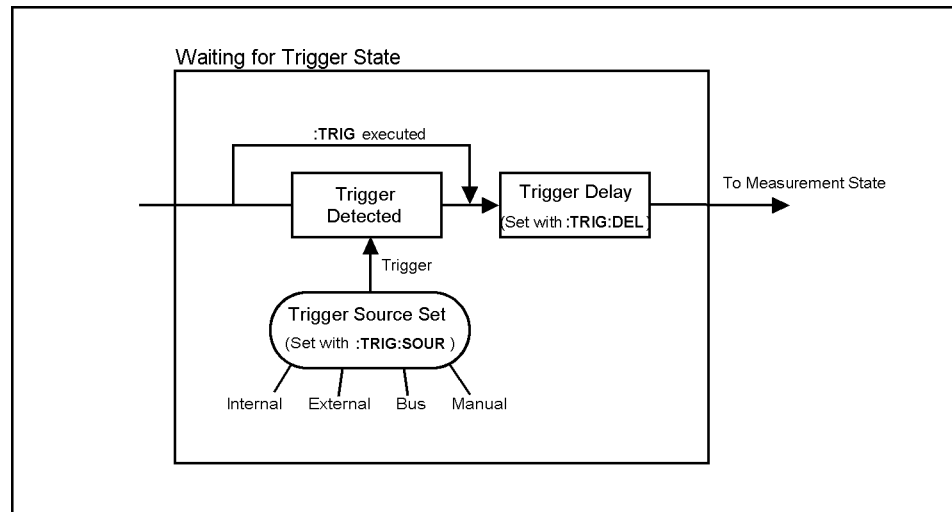

4287ape003

Measurement state (sequence operation state)

Measurement is performed in the measurement state. When the measurement is finished, the state transitions to a different state depending on the setup of the continuous activation of the trigger system (set with **:INIT:CONT** on page 183) as shown below.

When the continuous activation is OFF:

Transition to the idle state (c in Figure 5-1)

When the continuous activation is ON:

Transition to the waiting for trigger state (d in Figure 5-1)

Starting (triggering) measurement

Follow the procedure below to perform successive measurements automatically (initial setup).

- Step 1.** Set the trigger mode to the internal trigger with the **:TRIG:SOUR** command on page 196.
- Step 2.** If the trigger system has not started up (in the idle state), use the **:INIT:CONT** command on page 183 to turn ON the continuous activation of the trigger system.

Two methods to perform a measurement at your desired time:

Triggering the instrument at your desired time

- Step 1.** Use the **:TRIG:SOUR** command to set the trigger mode to the GPIB mode.
- Step 2.** If the trigger system has not started up (in the idle state), use the **:INIT:CONT** command to turn ON the continuous activation of the trigger system.
- Step 3.** Trigger the instrument at your desired time. An external controller can trigger the instrument with one of the following two commands:

Command	Query response	Applicable trigger mode
*TRG on page 128	Yes (The measured result is read out.)	GPIB trigger
:TRIG on page 195	No	All

- Step 4.** To repeat measurement, repeat Step 3.

Starting up the trigger system at your desired time

- Step 1.** If the trigger system has started up (in a state other than the idle state), use the **:INIT:CONT** command to turn OFF the continuous activation of the trigger system and then use the **:ABOR** command on page 130 to stop the trigger system.
- Step 2.** Set the trigger mode to the internal trigger with the **:TRIG:SOUR** command.
- Step 3.** Start up the trigger system with the **:INIT** command on page 183 at your desired time. The instrument will be automatically triggered by the internal trigger and measurement will be performed once.
- Step 4.** To repeat measurement, repeat Step 3.

Waiting For Completion Of Measurement (detecting completion of measurement)

You can detect the status of the 4288A by using the status register, as described in this section. For information on the entire status report system (for example, information on each bit of the status register), refer to Appendix C, “Status Reporting System.”

The measurement state is indicated by the operation status register (refer to Table C-3 on page 254). An SRQ (service request) is useful for detecting the completion of measurement in your program by using the information indicated by this register.

To detect the completion of measurement using SRQ, use the following commands.

- ***SRE** on page 127
- **:STAT:OPER:ENAB** on page 189

The procedure is given below.

- Step 1.** Make the setup so that the 4288A generates an SRQ if bit 4 of the operation status event register is set to 1.
- Step 2.** Trigger the instrument to start a measurement.
- Step 3.** Perform interrupt handling in the program when the SRQ occurs.

Figure 5-3

SRQ generation sequence (when measurement finishes)

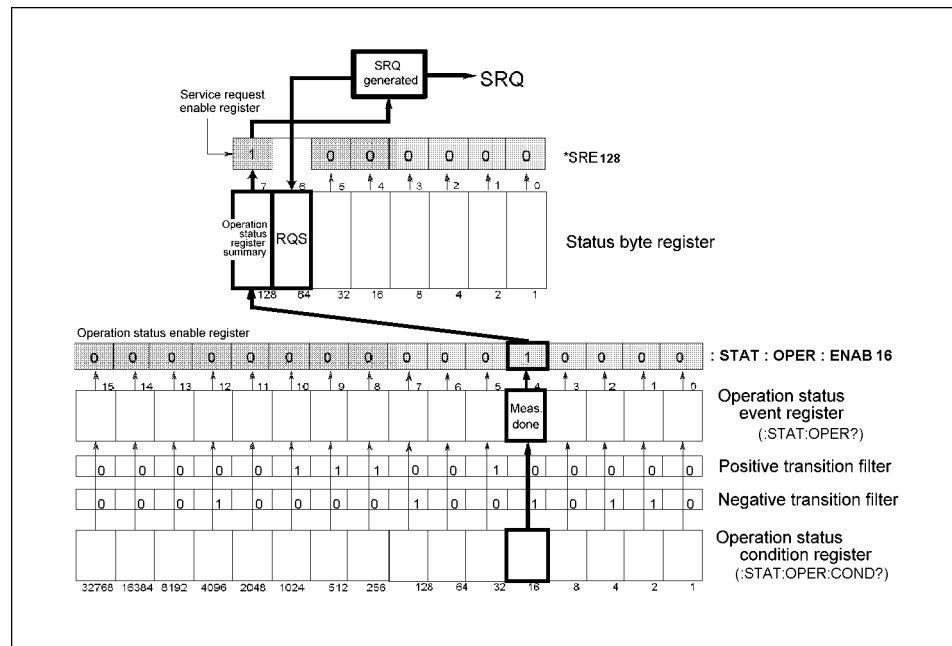

4288ape006

Starting (Triggering) Measurement and Waiting for Completion of Measurement Waiting For Completion Of Measurement (detecting completion of measurement)

Sample program

Example 5-1 shows a sample program to detect the completion of measurement using an SRQ. This program is stored on the sample program disk under the filename "srq_meas.bas."

This program stops the trigger system, sets up SRQ, and then starts up the trigger system once. When an SRQ of the completion of the measurement occurs, it displays a "Measurement Complete" message and finishes.

The program is detailed below.

Line 20	Sets the GPIB address.
Lines 40 to 60	Stops the trigger system and sets the trigger mode to the internal trigger.
Lines 80 to 90	Enables bit 4 of the operation status event register and enables bit 7 of the status byte register.
Lines 100 to 120	Clears the status byte register and operation status event register.
Lines 140 to 150	Sets the branch destination of the SRQ interrupt and enables the SRQ interrupt.
Lines 160 to 180	Starts up the trigger system once to start the measurement and waits for the completion of the measurement.
Line 230	Displays "Measurement Complete" message.

Example 5-1

Detecting the completion of measurement using SRQ (srq_meas.bas)

```
10 DIM Buff$(9)
20 ASSIGN @Agt4288a TO 717
30 !
40 OUTPUT @Agt4288a;":INIT:CONT OFF"
50 OUTPUT @Agt4288a;":ABOR"
60 OUTPUT @Agt4288a;":TRIG:SOUR INT"
70 !
80 OUTPUT @Agt4288a;":STAT:OPER:ENAB 16"
90 OUTPUT @Agt4288a;":*SRE 128"
100 OUTPUT @Agt4288a;":*CLS"
110 OUTPUT @Agt4288a;":*OPC?"
120 ENTER @Agt4288a;Buff$
130 !
140 ON INTR 7 GOTO Meas_end
150 ENABLE INTR 7;2
160 OUTPUT @Agt4288a;":INIT"
170 PRINT "Waiting..."
180 Meas_wait: GOTO Meas_wait
190 Meas_end: OFF INTR 7
200 PRINT "Measurement Complete"
210 END
```

6 Reading Out Measured Result

This chapter describes how to read out the measured result and the measurement signal level monitor result.

Data Transfer Format

You can select either the ASCII transfer format or binary transfer format when transferring data with the following commands.

NOTE

The ASCII transfer format is always used when transferring data with commands other than those listed below.

- **:FETC?** on page 181
- **:READ?** on page 186
- ***TRG** on page 128
- **:DATA** on page 168
- **:CORR:DATA** on page 158

To set up the data transfer format, use the following command.

- **:FORM** on page 182

ASCII transfer format

When data is transferred in the ASCII transfer format, values are transferred as ASCII bytes in one of the following formats. According to the specification of IEEE488.2, values are separated by a comma (,).

NOTE

The string length of numerical values is not constant. Therefore, the comma does not occur at constant intervals when extracting numerical values from the read out numerical data string.

- Integer format

The format shown in Figure 6-1. Numerical values are expressed as integers. For example, the value, 11, is expressed as “+11.”

Figure 6-1

Integer format

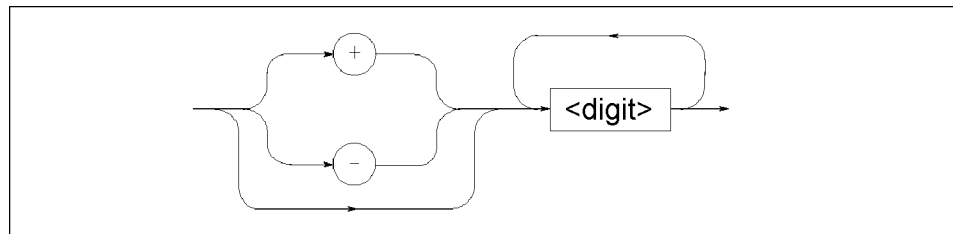

- Floating point format

The format shown in Figure 6-2. Numerical values are expressed using a floating point. For example, the value, 1000, is expressed as “+1.00000E+03.”

Figure 6-2

Floating point format

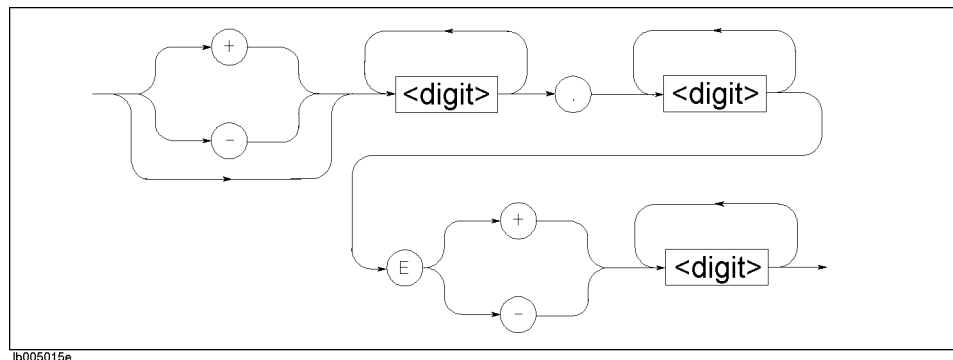

Binary transfer format

When data is transferred in the binary transfer format, values (binary data) are transferred in the format shown in Figure 6-3.

Figure 6-3 Binary transfer format

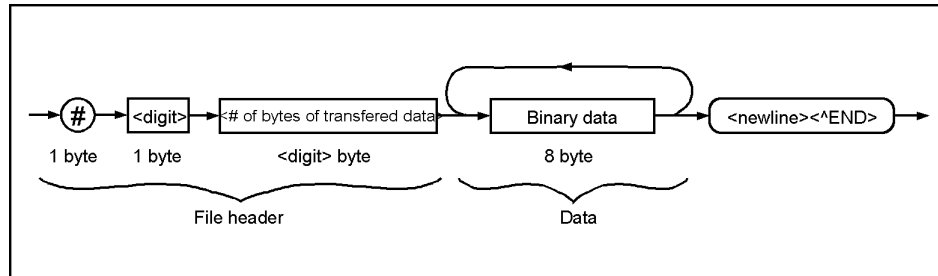

In this data transfer format, a pounds symbol (#) occurs at the beginning. The 2nd byte <digit count> indicates the number of bytes in the <transfer data byte count> part. The <transfer data byte count> indicates the total number of bytes of the binary data. <newline><^END> is the message terminator.

Binary data is in the IEEE 754 floating point format consisting of 64 bits as shown in Figure 6-4.

Figure 6-4 64-bit floating-point data

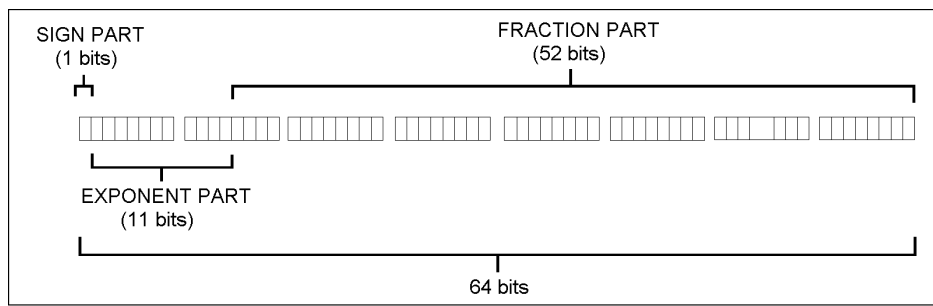

Byte order

In binary transfer, data bytes (8 bytes) are transferred from the byte including the MSB (Most Significant Bit) (the left-most byte in Figure 6-4) through the byte including the LSB (Least Significant Bit) (the right-most byte in Figure 6-4).

Reading Out Measured Result

This section describes how to read out the measured result.

You can read out the measured result in two ways: reading out data for each measurement or reading out data of several measurements in batch.

The three commands shown in the table below can be used to read out the measured data for each measurement.

	Available trigger mode	Readout procedure
Using the *TRG command	GPIB trigger (Bus)	Executing *TRG ↓ Readout
Using the :FETC? command	All	Triggering the instrument ↓ Executing :FETC? ↓ Readout
Using the :READ? command	External trigger (Ext) Internal trigger (Int)	Executing :READ? ↓ Triggering the instrument ↓ Readout

When you want to read out the data of several measurements in batch, use the data buffer.

Reading out measured result using *TRG command

This command actually performs two tasks: it triggers the instrument and returns the results. It is useful, for example, when you want to retrieve measurement results immediately after triggering the instrument from an external controller.

The readout procedure using the *TRG command is described below.

- Step 1.** Use the **:TRIG:SOUR** command on page 196 to set up the trigger mode to the GPIB trigger (Bus).
- Step 2.** Execute the ***TRG** command.
- Step 3.** Read out the measured result. To repeat the measurement, repeat Steps 2 and 3.

Example 6-1 and Example 6-2 show sample programs using the *TRG command. Example 6-1 is for the ASCII transfer format and Example 6-2 is for the binary transfer format. These programs are stored on the sample program disk under the filenames “trg_a.bas” and “trg_b.bas.”

These programs read out the measurement status, measured primary parameter result, measured secondary parameter result, and comparator sorting result (when the comparator function is ON) and then display this information.

The program of Example 6-1 is detailed below.

Line 60	Sets the GPIB address.
Line 70	Sets the data transfer format to the ASCII format.
Lines 90 to 100	Turns ON the trigger system continuous startup and sets the trigger mode to the GPIB trigger.
Lines 120 to 130	Reads out the ON/OFF state of the comparator function and assigns it to the Comp_flag variable.
Lines 170 to 210	After the trigger system state transitions to the trigger wait state, triggers the instrument.
Line 230	If the Comp_flag value is 1 (the comparator function is ON), reads out the measurement status, measured primary parameter result, measured secondary parameter result, and comparator sorting result.
Line 250	If the Comp_flag value is not 1 (the comparator function is OFF), reads out the measurement status, measured primary parameter result, and measured secondary parameter result.
Lines 300 to 320	Displays the measurement status, measured primary parameter result, and measured secondary parameter result.
Line 340	If the Comp_flag value is 1 (the comparator function is ON), displays the comparator sorting result.
Line 360	If the Comp_flag value is not 1 (the comparator function is OFF), displays “Comparator : OFF.”

Example 6-1

Reading out the measured result in ASCII transfer format by using the *TRG command (trg_a.bas)

```

10   DIM Buff$(9]
20   REAL Pri_para,Sec_para
30   INTEGER Meas_stat,Comp
40   INTEGER Comp_flag,Cond_reg
50   !
60   ASSIGN @Agt4288a TO 717
70   OUTPUT @Agt4288a;":FORM ASC"
80   !
90   OUTPUT @Agt4288a;":INIT:CONT ON"
100  OUTPUT @Agt4288a;":TRIG:SOUR BUS"
110  !
120  OUTPUT @Agt4288a;":CALC:COMP?"
130  ENTER @Agt4288a;Comp_flag
140  !
150  ! Triggering and data read
160  !
170  REPEAT
180    OUTPUT @Agt4288a;":STAT:OPER:COND?"
190    ENTER @Agt4288a;Cond_reg
200  UNTIL BIT(Cond_reg,5)
210  OUTPUT @Agt4288a;"*TRG"
220  IF Comp_flag=1 THEN
230    ENTER @Agt4288a;Meas_stat,Pri_para,Sec_para,Comp
240  ELSE
250    ENTER @Agt4288a;Meas_stat,Pri_para,Sec_para
260  END IF
270  !
280  ! Display results
290  !
300  PRINT USING "15A,X,D";"Meas. status :",Meas_stat
310  PRINT USING "15A,X,SD.5DE";"Pri. parameter:",Pri_para
320  PRINT USING "15A,X,SD.5DE";"Sec. parameter:",Sec_para
330  IF Comp_flag=1 THEN
340    PRINT USING "15A,X,K";"Comparator      :",Comp
350  ELSE
360    PRINT USING "19A";"Comparator      : OFF"
370  END IF
380  END

```

Reading Out Measured Result

Reading Out Measured Result

The program of Example 6-2 is detailed below.

Lines 50 to 60	Sets the GPIB address.
Line 70	Sets the data transfer format to the binary format.
Lines 90 to 100	Turns ON the trigger system continuous startup and sets the trigger mode to the GPIB trigger.
Lines 120 to 130	Reads out the ON/OFF state of the comparator function and assigns it to the Comp_flag variable.
Lines 170 to 210	After the trigger system state transitions to the trigger wait state, triggers the instrument.
Lines 220 to 250	Reads out the header part.
Line 270	If the Comp_flag value is 1 (the comparator function is ON), reads out the measurement status, measured primary parameter result, measured secondary parameter result, and comparator sorting result.

NOTE

Binary data must be read out without formatting. Therefore, use an I/O path (@Binary) set up for such readout. This is also applicable to Line 290.

Line 290	If the Comp_flag value is not 1 (the comparator function is OFF), reads out the measurement status, measured primary parameter result, and measured secondary parameter result.
Line 310	Reads out the message terminator at the end of the data.
Lines 350 to 370	Displays the measurement status, measured primary parameter result, and measured secondary parameter result.
Line 390	If the Comp_flag value is 1 (the comparator function is ON), displays the comparator sorting result.
Line 410	If the Comp_flag value is not 1 (the comparator function is OFF), displays “Comparator : OFF.”

Example 6-2

Reading out the measured result in binary transfer format using *TRG command (trg_b.bas)

```

10   DIM Buff$[9],Digit$[1],Read_form$[9],Num_of_byte$[9]
20   REAL Pri_para,Sec_para
30   REAL Meas_stat,Comp
40   INTEGER Comp_flag,Cond_reg
50   ASSIGN @Binary TO 717;FORMAT OFF
60   ASSIGN @Agt4288a TO 717
70   OUTPUT @Agt4288a;":FORM REAL"
80   !
90   OUTPUT @Agt4288a;":INIT:CONT ON"
100  OUTPUT @Agt4288a;":TRIG:SOUR BUS"
110  !
120  OUTPUT @Agt4288a;":CALC:COMP?"
130  ENTER @Agt4288a;Comp_flag
140  !
150  ! Triggering and data read
160  !
170  REPEAT
180    OUTPUT @Agt4288a;":STAT:OPER:COND?"
190    ENTER @Agt4288a;Cond_reg
200  UNTIL BIT(Cond_reg,5)
210  OUTPUT @Agt4288a;"*TRG"
220  ENTER @Agt4288a USING "#,A";Buff$
230  ENTER @Agt4288a USING "#,A";Digit$
240  Read_form$="#",&Digit$&"A"
250  ENTER @Agt4288a USING Read_form$;Num_of_byte$
260  IF Comp_flag=1 THEN
270    ENTER @Binary;Meas_stat,Pri_para,Sec_para,Comp
280  ELSE
290    ENTER @Binary;Meas_stat,Pri_para,Sec_para
300  END IF
310  ENTER @Agt4288a USING "#,A";Buff$
320  !
330  ! Display results
340  !
350  PRINT USING "15A,X,D";"Meas. status :",Meas_stat
360  PRINT USING "15A,X,SD.5DE";"Pri. parameter:",Pri_para
370  PRINT USING "15A,X,SD.5DE";"Sec. parameter:",Sec_para
380  IF Comp_flag=1 THEN
390    PRINT USING "15A,X,K";"Comparator      :",Comp
400  ELSE
410    PRINT USING "19A";"Comparator      : OFF"
420  END IF
430  END

```

Reading out measured result using **:FETC?** command

You can use this readout method when you want to trigger the instrument from any source other than an external controller or when you want to perform a process that is between triggering the instrument and reading out the measured result.

The readout procedure using the **:FETC?** command is described below.

- Step 1.** Set up the trigger mode as necessary.
- Step 2.** Trigger the instrument by using the method for the trigger mode.

NOTE

To trigger the instrument from an external controller in this procedure, use the **:TRIG** command on page 195.

- Step 3.** Execute the **:FETC?** command at the completion of the measurement.
- Step 4.** Read out the measured result. To repeat the measurement, repeat Steps 2 to 4.

Example 6-3 and Example 6-4 show sample programs using the **:FETC?** command. Example 6-3 is for the ASCII transfer format and Example 6-4 is for the binary transfer format. These programs are stored on the sample program disk under the filenames “fetch_a.bas” and “fetch_b.bas.”

These programs, when an external trigger is inputted and the measurement finishes, read out the measurement status, measured primary parameter result, measured secondary parameter result, and comparator sorting result (when the comparator function is ON) and display them.

The program of Example 6-3 is detailed below.

Line 60	Sets the GPIB address.
Line 70	Sets the data transfer format to the ASCII format.
Lines 90 to 100	Turns ON the trigger system continuous startup and sets the trigger mode to the external trigger.
Lines 120 to 130	Reads out the ON/OFF state of the comparator function and assigns it into the Comp_flag variable.
Lines 170 to 210	Makes the setup generate an SRQ when measurement finishes and clears the status byte register and operation status event register.
Lines 250 to 260	Sets the branch destination of the SRQ interrupt and enables the SRQ interrupt.
Lines 270 to 280	Displays the message to prompt the user to input an external trigger and then waits until the external trigger is inputted and the measurement finishes.
Line 300	Executes the measured result readout command (:FETC?).
Line 320	If the Comp_flag value is 1 (the comparator function is ON), reads out the measurement status, measured primary parameter result, measured secondary parameter result, and comparator sorting result.
Line 340	If the Comp_flag value is not 1 (the comparator function is OFF), reads out the measurement status, measured primary parameter result, and measured secondary parameter result.

- Lines 390 to 410 Displays the measurement status, measured primary parameter result, and measured secondary parameter result.
- Line 430 If the Comp_flag value is 1 (the comparator function is ON), displays the comparator sorting result.
- Line 450 If the Comp_flag value is not 1 (the comparator function is OFF), displays "Comparator : OFF."

Example 6-3

Reading out the measured result in ASCII transfer format using the :FETC? command (fetch_a.bas)

```

10   DIM Buff$(9]
20   REAL Pri_para,Sec_para
30   INTEGER Meas_stat,Comp
40   INTEGER Comp_flag
50   !
60   ASSIGN @Agt4288a TO 717
70   OUTPUT @Agt4288a;":FORM ASC"
80   !
90   OUTPUT @Agt4288a;":INIT:CONT ON"
100  OUTPUT @Agt4288a;":TRIG:SOUR EXT"
110  !
120  OUTPUT @Agt4288a;":CALC:COMP?"
130  ENTER @Agt4288a;Comp_flag
140  !
150  ! SRQ setting
160  !
170  OUTPUT @Agt4288a;":STAT:OPER:ENAB 16"
180  OUTPUT @Agt4288a;"*SRE 128"
190  OUTPUT @Agt4288a;"*CLS"
200  OUTPUT @Agt4288a;"*OPC?"
210  ENTER @Agt4288a;Buff$
220  !
230  ! Triggering and data read
240  !
250  ON INTR 7 GOTO Meas_end
260  ENABLE INTR 7;2
270  PRINT "Waiting for External Trigger!"
280 Meas_wait: GOTO Meas_wait
290 Meas_end:  OFF INTR 7
300  OUTPUT @Agt4288a;":FETC?"
310  IF Comp_flag=1 THEN
320     ENTER @Agt4288a;Meas_stat,Pri_para,Sec_para,Comp
330  ELSE
340     ENTER @Agt4288a;Meas_stat,Pri_para,Sec_para
350  END IF
360  !
370  ! Display results
380  !
390  PRINT USING "15A,X,D";"Meas. status :",Meas_stat
400  PRINT USING "15A,X,SD.5DE";"Pri. parameter:",Pri_para
410  PRINT USING "15A,X,SD.5DE";"Sec. parameter:",Sec_para
420  IF Comp_flag=1 THEN
430     PRINT USING "15A,X,K";"Comparator      :",Comp
440  ELSE
450     PRINT USING "19A";"Comparator      : OFF"
460  END IF
470  END

```

Reading Out Measured Result

Reading Out Measured Result

The program of Example 6-4 is detailed below.

Lines 50 to 60	Sets the GPIB address.
Line 70	Sets the data transfer format to the binary format.
Lines 90 to 100	Turns ON the trigger system continuous startup and sets the trigger mode to the external trigger.
Lines 120 to 130	Reads out the ON/OFF state of the comparator function and assigns it to the Comp_flag variable.
Lines 170 to 210	Makes the setup generate an SRQ when measurement finishes and clears the status byte register and operation status event register.
Lines 250 to 260	Sets the branch destination of the SRQ interrupt and enables the SRQ interrupt.
Lines 270 to 280	Displays the message to prompt the user to input an external trigger and then waits until the external trigger is inputted and the measurement finishes.
Line 300	Executes the measured result readout command (:FETC?).
Lines 310 to 340	Reads out the header part.
Line 360	If the Comp_flag value is 1 (the comparator function is ON), reads out the measurement status, measured primary parameter result, measured secondary parameter result, and comparator sorting result.

NOTE

Binary data must be read out without formatting. Therefore, use an I/O path (@Binary) set up as such for readout. This is also applicable to Line 380.

Line 380	If the Comp_flag value is not 1 (the comparator function is OFF), reads out the measurement status, measured primary parameter result, and measured secondary parameter result.
Line 400	Reads out the message terminator at the end of the data.
Lines 440 to 460	Displays the measurement status, measured primary parameter result, and measured secondary parameter result.
Line 480	If the Comp_flag value is 1 (the comparator function is ON), displays the comparator sorting result.
Line 500	If the Comp_flag value is not 1 (the comparator function is OFF), displays "Comparator : OFF."

Example 6-4

Reading out measured result in binary transfer format using :FETC? command (fetch_b.bas)

```

10   DIM Buff$(9),Digit$(1),Read_form$(9),Num_of_byte$(9)
20   REAL Pri_para,Sec_para
30   REAL Meas_stat,Comp
40   INTEGER Comp_flag
50   ASSIGN @Binary TO 717;FORMAT OFF
60   ASSIGN @Agt4288a TO 717
70   OUTPUT @Agt4288a;":FORM REAL"
80   !
90   OUTPUT @Agt4288a;":INIT:CONT ON"
100  OUTPUT @Agt4288a;":TRIG:SOUR EXT"
110  !
120  OUTPUT @Agt4288a;":CALC:COMP?"
130  ENTER @Agt4288a;Comp_flag
140  !
150  ! SRQ setting
160  !
170  OUTPUT @Agt4288a;":STAT:OPER:ENAB 16"
180  OUTPUT @Agt4288a;"*SRE 128"
190  OUTPUT @Agt4288a;"*CLS"
200  OUTPUT @Agt4288a;"*OPC?"
210  ENTER @Agt4288a;Buff$
220  !
230  ! Triggering and data read
240  !
250  ON INTR 7 GOTO Meas_end
260  ENABLE INTR 7;2
270  PRINT "Waiting for External Trigger!"
280 Meas_wait: GOTO Meas_wait
290 Meas_end:  OFF INTR 7
300  OUTPUT @Agt4288a;":FETC?"
310  ENTER @Agt4288a USING "#,A";Buff$
320  ENTER @Agt4288a USING "#,A";Digit$
330  Read_form$="#,&Digit$&"A"
340  ENTER @Agt4288a USING Read_form$;Num_of_byte$
350  IF Comp_flag=1 THEN
360    ENTER @Binary;Meas_stat,Pri_para,Sec_para,Comp
370  ELSE
380    ENTER @Binary;Meas_stat,Pri_para,Sec_para
390  END IF
400  ENTER @Agt4288a USING "#,A";Buff$
410  !
420  ! Display results
430  !
440  PRINT USING "15A,X,D";"Meas. status :",Meas_stat
450  PRINT USING "15A,X,SD.5DE";"Pri. parameter:",Pri_para
460  PRINT USING "15A,X,SD.5DE";"Sec. parameter:",Sec_para
470  IF Comp_flag=1 THEN
480    PRINT USING "15A,X,K";"Comparator      :",Comp
490  ELSE
500    PRINT USING "19A";"Comparator      : OFF"
510  END IF
520  END

```

Reading out measured result using :READ? command

You can use this readout method when you want to read out the result synchronously with the completion of measurement without detecting the time of trigger in the trigger wait state in your program. Therefore, this is useful, for example, when you want to trigger the instrument from external equipment such as a handler and read out the result using an external controller immediately after the completion of measurement.

The readout procedure using the **:READ?** command is described below.

- Step 1.** Use the **:TRIG:SOUR** command on page 196 to set the trigger mode to internal trigger (Internal) or external trigger (External).
- Step 2.** Execute the **:READ?** command.
- Step 3.** Trigger the instrument using the method for the trigger mode setup.
- Step 4.** Read out the measured result. To repeat the measurement, repeat Steps 2 to 4.

Example 6-5 and Example 6-6 show sample programs using the **:READ?** command. Example 6-5 is for the ASCII transfer format and Example 6-6 is for the binary transfer format. These programs are stored on the sample program disk under the filenames “read_a.bas” and “read_b.bas.”

These programs, when an external trigger is inputted and the measurement finishes, read out the measurement status, measured primary parameter result, measured secondary parameter result, and comparator sorting result (when the comparator function is ON) and then display this information.

The program of Example 6-5 is detailed below.

Line 60	Sets the GPIB address.
Line 70	Sets the data transfer format to the ASCII format.
Lines 90 to 100	Turns OFF the trigger system continuous startup and sets the trigger mode to external trigger.
Lines 120 to 130	Reads out the ON/OFF state of the comparator function and assigns it to the Comp_flag variable.
Lines 170 to 180	Executes the :READ? command, displays the message to prompt the user to input an external trigger, and waits until the external trigger is inputted and the measurement finishes.
Line 200	If the Comp_flag value is 1 (the comparator function is ON), reads out the measurement status, measured primary parameter result, measured secondary parameter result, and comparator sorting result.
Line 220	If the Comp_flag value is not 1 (the comparator function is OFF), reads out the measurement status, measured primary parameter result, and measured secondary parameter result.
Lines 270 to 290	Displays the measurement status, measured primary parameter result, and measured secondary parameter result.
Line 310	If the Comp_flag value is 1 (the comparator function is ON), displays the comparator sorting result.
Line 330	If the Comp_flag value is not 1 (the comparator function is OFF), displays “Comparator : OFF.”

Example 6-5

Reading out the measured result in ASCII transfer format using the :READ? command (read_a.bas)

```

10   DIM Buff$(9]
20   REAL Pri_para,Sec_para
30   INTEGER Meas_stat,Comp
40   INTEGER Comp_flag
50   !
60   ASSIGN @Agt4288a TO 717
70   OUTPUT @Agt4288a;":FORM ASC"
80   !
90   OUTPUT @Agt4288a;":INIT:CONT OFF"
100  OUTPUT @Agt4288a;":TRIG:SOUR EXT"
110  !
120  OUTPUT @Agt4288a;":CALC:COMP?"
130  ENTER @Agt4288a;Comp_flag
140  !
150  ! Triggering and data read
160  !
170  OUTPUT @Agt4288a;":READ?"
180  PRINT "Waiting for External Trigger!"
190  IF Comp_flag=1 THEN
200      ENTER @Agt4288a;Meas_stat,Pri_para,Sec_para,Comp
210  ELSE
220      ENTER @Agt4288a;Meas_stat,Pri_para,Sec_para
230  END IF
240  !
250  ! Display results
260  !
270  PRINT USING "15A,X,D";"Meas. status :",Meas_stat
280  PRINT USING "15A,X,SD.5DE";"Pri. parameter:",Pri_para
290  PRINT USING "15A,X,SD.5DE";"Sec. parameter:",Sec_para
300  IF Comp_flag=1 THEN
310      PRINT USING "15A,X,K";"Comparator      :",Comp
320  ELSE
330      PRINT USING "19A";"Comparator      : OFF"
340  END IF
350  END

```

Reading Out Measured Result

Reading Out Measured Result

The program of Example 6-6 is detailed below.

Lines 50 to 60	Sets the GPIB address.
Line 70	Sets the data transfer format to the binary format.
Lines 90 to 100	Turns OFF the trigger system continuous startup and sets the trigger mode to external trigger.
Lines 120 to 130	Reads out the ON/OFF state of the comparator function and sets it to the Comp_flag variable.
Lines 170 to 180	Executes the :READ? command, displays the message to prompt the user to input an external trigger, and waits until the external trigger is inputted and the measurement finishes.
Lines 190 to 220	Reads out the header part.
Line 240	If the Comp_flag value is 1 (the comparator function is ON), reads out the measurement status, measured primary parameter result, measured secondary parameter result, and comparator sorting result.
Line 260	If the Comp_flag value is not 1 (the comparator function is OFF), reads out the measurement status, measured primary parameter result, and measured secondary parameter result.
Line 280	Reads out the message terminator at the end of the data.
Lines 320 to 340	Displays the measurement status, measured primary parameter result, and measured secondary parameter result.
Line 360	If the Comp_flag value is 1 (the comparator function is ON), displays the comparator sorting result.
Line 380	If the Comp_flag value is not 1 (the comparator function is OFF), displays “Comparator : OFF.”

Example 6-6

Reading out the measured result in binary transfer format using the :READ? command (read_b.bas)

```

10   DIM Buff$(9),Digit$(1),Read_form$(9),Num_of_byte$(9)
20   REAL Pri_para,Sec_para
30   REAL Meas_stat,Comp
40   INTEGER Comp_flag
50   ASSIGN @Binary TO 717;FORMAT OFF
60   ASSIGN @Agt4288a TO 717
70   OUTPUT @Agt4288a;":FORM REAL"
80   !
90   OUTPUT @Agt4288a;":INIT:CONT OFF"
100  OUTPUT @Agt4288a;":TRIG:SOUR EXT"
110  !
120  OUTPUT @Agt4288a;":CALC:COMP?"
130  ENTER @Agt4288a;Comp_flag
140  !
150  ! Triggering and data read
160  !
170  PRINT "Waiting for External Trigger!"
180  OUTPUT @Agt4288a;":READ?"
190  ENTER @Agt4288a USING "#,A";Buff$
200  ENTER @Agt4288a USING "#,A";Digit$
210  Read_form$="#,&Digit$&"A"
220  ENTER @Agt4288a USING Read_form$;Num_of_byte$
230  IF Comp_flag=1 THEN
240     ENTER @Binary;Meas_stat,Pri_para,Sec_para,Comp
250  ELSE
260     ENTER @Binary;Meas_stat,Pri_para,Sec_para
270  END IF
280  ENTER @Agt4288a USING "#,A";Buff$
290  !
300  ! Display results
310  !
320  PRINT USING "15A,X,D";"Meas. status :",Meas_stat
330  PRINT USING "15A,X,SD.5DE";"Pri. parameter:",Pri_para
340  PRINT USING "15A,X,SD.5DE";"Sec. parameter:",Sec_para
350  IF Comp_flag=1 THEN
360     PRINT USING "15A,X,K";"Comparator      :",Comp
370  ELSE
380     PRINT USING "19A";"Comparator      : OFF"
390  END IF
400  END

```

Trigger input timing when using :READ? command

You must input a trigger after execution of the **:READ?** command. Therefore, if you use different controllers for outputting the trigger and executing the **:READ?** command, you need to find out whether the **:READ?** command has been executed from the controller for outputting the trigger in order to prepare the proper timing for trigger output (to trigger the instrument after execution of the **:READ?** command).

You can obtain this information from the `/READY_FOR_TRIG` signal of the handler interface as shown in Figure 6-5.

Figure 6-5

Behavior of /READY_FOR_TRIG signal at execution of :READ? command

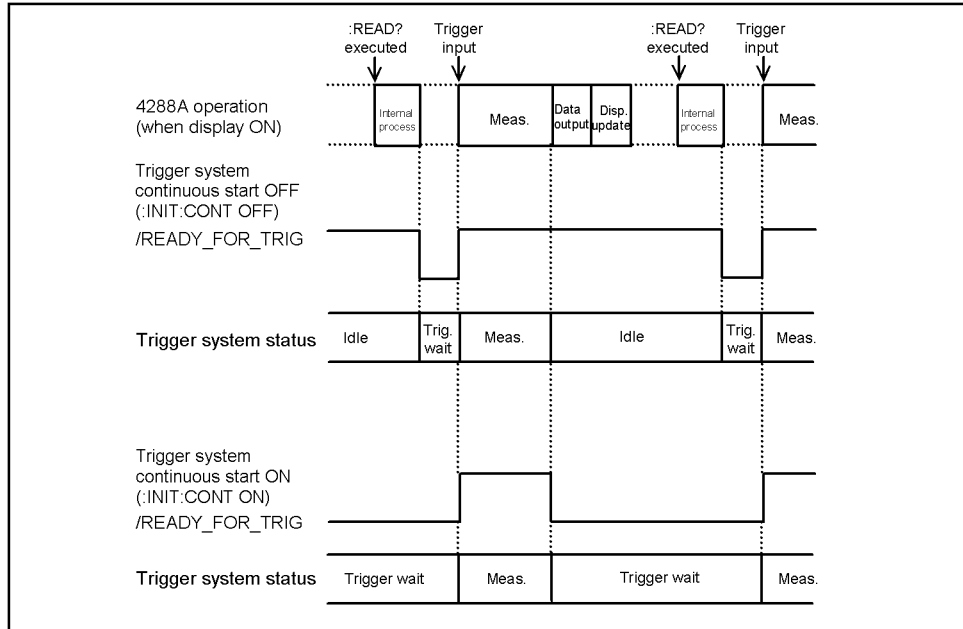

4288ape011

If the **:READ?** command is executed when the trigger system is in the idle state, the `/READY_FOR_TRIG` signal of the handler interface changes from HIGH to LOW after completion of the internal processing following the reception of the command as shown in Figure 6-5.

If the trigger system continuous startup is ON, the `/READY_FOR_TRIG` signal changes from HIGH to LOW (the trigger system transitions to the trigger wait state instead of the idle state) after the completion of measurement and display update as shown in Figure 6-5. As a result, it is not possible to determine whether the **:READ?** command has actually been executed. Therefore, you need to turn OFF the trigger system continuous startup (execute the **:INIT:CONT** command on page 183 specifying OFF) in advance.

NOTE

In Figure 6-5, the **:READ?** command is executed after display is updated. In practice, you may execute the **:READ?** command before or during display update provided that data output has finished (after completion of the query of the previous **:READ?** command). However, the internal processing is started after the completion of display update.

The 4288A normally updates display after data output as shown in Figure 6-5. However, if readout of data stagnates due to the external controller, the 4288A may update display before data output.

Reading out results of several measurements in batch (using data buffer)

You can use the data buffer to temporarily store the results of several measurements and then later read out these results in batch.

Data buffer types

There are three types of data buffers (buffers 1–3). Buffers 1 and 2 have the same function. Buffer 3 has a different function as shown in the below table.

		Buffers 1 and 2	Buffer 3
Maximum number of measurements that can be fed		200	1000
Data to be fed for each measurement	When the comparator function is OFF	3 data items: measurement status, measured value of the primary parameter or secondary parameter *1, and comparator sorting result *2	3 data items: measurement status, measured primary parameter value, and measured secondary parameter value
	When the comparator function is ON	(Independent of ON/OFF of the comparator function)	4 data items: measurement status, measured primary parameter value, measured secondary parameter value, and comparator sorting result

*1. Use the **:DATA:FEED** command on page 173 to select the parameter to store into the buffer from the primary or secondary parameters.

*2. When the comparator function is OFF, 11 is read out.

Feed position

Data fed into the buffer is stored sequentially in the order of measurement. When the data is read out, the feed position returns to the beginning of the buffer and storage newly starts from the position of the first data set (Figure 6-6).

The feed position also returns to the beginning of the buffer in the following cases:

- When you set up the number of measurements to be fed into the data buffer
- When you do not read out data and continue measurement after the maximum number of measurements that can be fed into the data buffer is reached (in this case, the data are overwritten from the beginning and the previous data will be lost)

Figure 6-6 Structure of data buffer

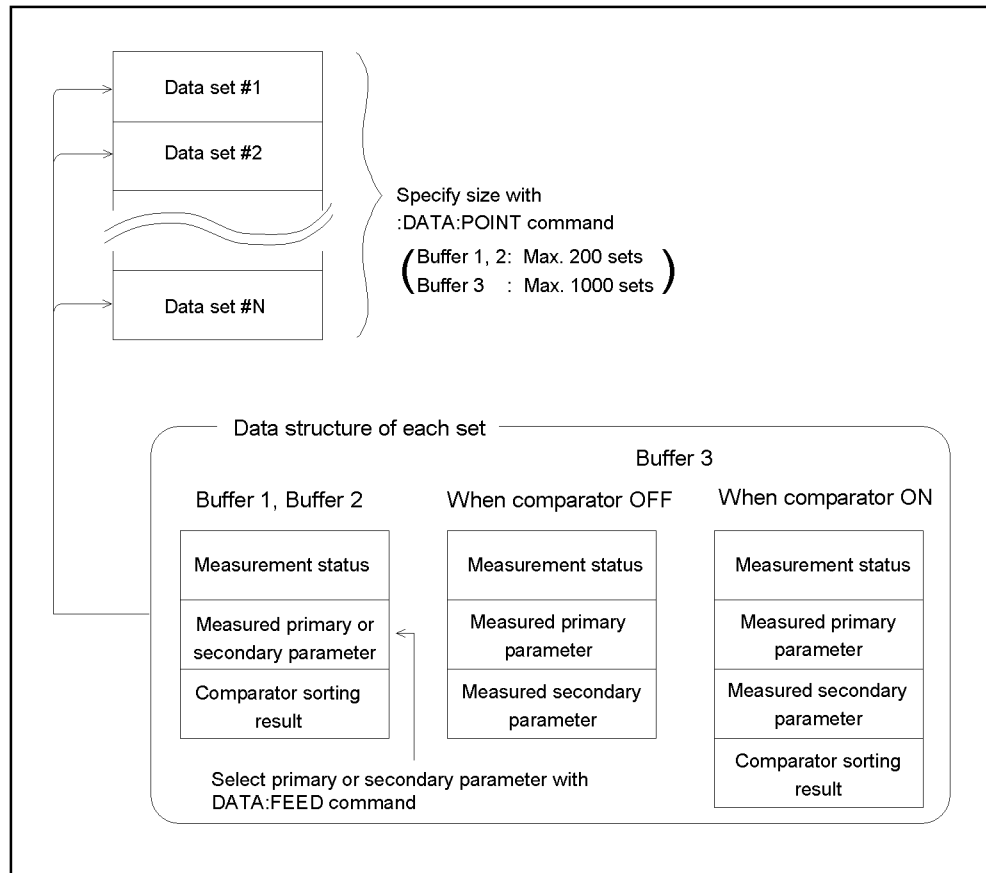

4288ape014

Procedure for use

- Step 1.** Use the **:DATA:POIN** command on page 175 to set up the number of measurements you want to feed into the data buffer.
- Step 2.** When you use buffer 1 or buffer 2, use the **:DATA:FEED** command on page 173 to select whether the parameter is fed from the primary or secondary parameter.
- Step 3.** Use the **:DATA:FEED:CONT** command on page 174 to make the setup feed the measured result into the data buffer.
- Step 4.** Execute the measurement for the number of times specified in Step 1.
- Step 5.** Use the **:DATA** command on page 168 to read out the data temporarily stored in the data buffer.
- Step 6.** Repeat Steps 4 to 5.

Sample program

Example 6-7 shows a sample program to read out the measured result using the data buffer. This program is stored on the sample program disk under the filename "data_buf.bas."

This program executes measurement 50 times, reads out the results of the 50 measurements in batch using data buffer 3, and then displays this information.

The program is detailed below.

Lines 40 to 50	Sets the GPIB address.
Line 70	Assigns the number of measurements to be fed into the data buffer (50 times) to the Point variable.
Line 90	Sets the data transfer format to the binary format.
Lines 110 to 120	Turns ON the trigger system continuous startup and sets the trigger mode to the GPIB trigger.
Lines 140 to 150	Reads out the ON/OFF state of the comparator function and assigns it to the Comp_flag variable.
Line 170	If the Comp_flag value is 1 (the comparator function is ON), redefines the size of the array data so that the number of data items for each measurement is 4.
Line 190	If the Comp_flag value is not 1 (the comparator function is OFF), redefines the size of the array data so that the number of data items for each measurement is 3.
Lines 220 to 230	Sets the number of measurements to be fed into the data buffer to 'Point' and makes the setup feed the measured result into the data buffer.
Lines 270 to 310	Repeats the measurement until data buffer 3 becomes full.
Lines 350 to 410	Reads out data buffer 3.
Lines 470 to 530	If the Comp_flag value is 1 (the comparator function is ON), displays the measurement status, measured primary parameter value, measured secondary parameter value, and comparator sorting result.
Lines 550 to 610	If the Comp_flag value is not 1 (the comparator function is OFF), displays the measurement status, measured primary parameter value, and measured secondary parameter value.

Example 6-7

Reading out measured result using data buffer (data_buf.bas)

```

10 DIM Buff$(9),Digit$(1),Read_form$(9),Num_of_byte$(9),Img$(50)
20 REAL Data(1:1000,1:4)
30 INTEGER Point,Comp_flag,Cond_reg
40 ASSIGN @Binary TO 717;FORMAT OFF
50 ASSIGN @Agt4288a TO 717
60 !
70 Point=50
80 !
90 OUTPUT @Agt4288a;" :FORM REAL"
100 !
110 OUTPUT @Agt4288a;" :INIT:CONT ON"
120 OUTPUT @Agt4288a;" :TRIG:SOUR BUS"
130 !
140 OUTPUT @Agt4288a;" :CALC:COMP?"

```

Reading Out Measured Result

Reading Out Measured Result

```
150   ENTER @Agt4288a;Comp_flag
160   IF Comp_flag=1 THEN
170     REDIM Data(1:Point,1:4)
180   ELSE
190     REDIM Data(1:Point,1:3)
200   END IF
210   !
220   OUTPUT @Agt4288a;":DATA:POIN BUF3,";Point
230   OUTPUT @Agt4288a;":DATA:FEED:CONT BUF3,ALW"
240   !
250   ! Triggering
260   !
270   REPEAT
280     OUTPUT @Agt4288a;":TRIG"
290     OUTPUT @Agt4288a;":STAT:OPER:COND?"
300     ENTER @Agt4288a;Cond_reg
310   UNTIL BIT(Cond_reg,10)
320   !
330   ! Data reading
340   !
350   OUTPUT @Agt4288a;":DATA? BUF3"
360   ENTER @Agt4288a USING "#,A";Buff$
370   ENTER @Agt4288a USING "#,A";Digit$
380   Read_form$="#,&Digit$&"A"
390   ENTER @Agt4288a USING Read_form$;Num_of_byte$
400   ENTER @Binary;Data(*)
410   ENTER @Agt4288a USING "#,A";Buff$
420   !
430   ! Display results
440   !
450   CLEAR SCREEN
460   IF Comp_flag=1 THEN
470     Img$="4D,3X,D,4X,MD.4DE,2X,MD.4DE,2X,2D"
480     PRINT "[MEASUREMENT and BIN SORT RESULT]"
490     PRINT "      Status      Pri          Sec          BIN"
500     PRINT "-----"
510     FOR I=1 TO Point
520       PRINT USING Img$;I,Data(I,1),Data(I,2),Data(I,3),Data(I,4)
530     NEXT I
540   ELSE
550     Img$="4D,3X,D,4X,MD.4DE,2X,MD.4DE"
560     PRINT "[MEASUREMENT RESULT]"
570     PRINT "      Status      Pri          Sec          "
580     PRINT "-----"
590     FOR I=1 TO Point
600       PRINT USING Img$;I,Data(I,1),Data(I,2),Data(I,3)
610     NEXT I
620   END IF
630   END
```

Reading out measurement signal level monitor result

To read out measurement signal level monitor result, use the following command:

- `:DATA? {IMON|VMON}` on page 171

Example 6-8 shows a sample program to read out the measurement signal level monitor result. This program is stored on the sample program disk under the filename “lvl_mon.bas.”

This program turns ON the measurement signal level monitor function, performs measurement once, and reads out and displays the measurement signal level monitor result.

The program is detailed below.

Line 40	Sets the GPIB address.
Line 50	Sets the data transfer format to the ASCII format.
Lines 70 to 80	Turns ON the measurement signal level current & voltage monitor function.
Line 90	Makes the setup display the measurement signal level monitor result in the instrument setup display area.
Lines 110 to 120	Turns ON the trigger system continuous startup and sets the trigger mode to GPIB trigger.
Lines 160 to 200	Makes the setup generate an SRQ when measurement finishes and clears the status byte register and operation status event register.
Lines 240 to 250	Sets the branch destination of the SRQ interrupt and enables the SRQ interrupt.
Lines 260 to 270	Triggers the measurement through GPIB and waits for the completion of measurement.
Lines 290 to 300	Reads out the voltage monitor value of the measurement signal level.
Lines 310 to 320	Reads out the current monitor value of the measurement signal level.
Lines 360 to 410	Converts the voltage monitor value and current monitor value of the measurement signal level into mV and μ A, respectively, and displays them.

Reading Out Measured Result
Reading out measurement signal level monitor result

Example 6-8 **Reading out the measurement signal level monitor result (lvl_mon.bas)**

```
10     DIM Buff$(9)
20     REAL V_mon,I_mon
30     !
40     ASSIGN @Agt4288a TO 717
50     OUTPUT @Agt4288a;" :FORM ASC"
60     !
70     OUTPUT @Agt4288a;" :CALC3:MATH:STAT ON"
80     OUTPUT @Agt4288a;" :CALC4:MATH:STAT ON"
90     OUTPUT @Agt4288a;" :DISP:TEXT2:PAGE 4"
100    !
110    OUTPUT @Agt4288a;" :INIT:CONT ON"
120    OUTPUT @Agt4288a;" :TRIG:SOUR BUS"
130    !
140    ! SRQ setting
150    !
160    OUTPUT @Agt4288a;" :STAT:OPER:ENAB 16"
170    OUTPUT @Agt4288a;" *SRE 128"
180    OUTPUT @Agt4288a;" *CLS"
190    OUTPUT @Agt4288a;" *OPC?"
200    ENTER @Agt4288a;Buff$
210    !
220    ! Triggering and level monitor data read
230    !
240    ON INTR 7 GOTO Meas_end
250    ENABLE INTR 7;2
260    OUTPUT @Agt4288a;" :TRIG"
270 Meas_wait:  GOTO Meas_wait
280 Meas_end:   OFF INTR 7
290    OUTPUT @Agt4288a;" :DATA? VMON"
300    ENTER @Agt4288a;V_mon
310    OUTPUT @Agt4288a;" :DATA? IMON"
320    ENTER @Agt4288a;I_mon
330    !
340    ! Display results
350    !
360    IF V_mon<9.9E37 THEN
370        PRINT USING "8A,6D.3D,3A";"Voltage: ",V_mon*1.E+3," mV"
380        PRINT USING "8A,6D.3D,3A";"Current: ",I_mon*1.E+6," uA"
390    ELSE
400        PRINT "Overload!"
410    END IF
420    END
```

7 **Sorting Based on Measured Result (Comparator Function)**

This chapter describes how to use the comparator function to perform sorting based on the measured result.

Setting Up Comparator Function

Turning ON/OFF comparator function

To enable/disable the comparator function, use the following command.

- **:CALC:COMP** on page 134

Setting up limit range

Clearing (resetting) limit range

You can clear the ON/OFF state and the lower and upper limit values of all limit ranges (BIN1 to BIN9 and the secondary parameter limit range) and the ON/OFF state of AUX BIN to recover the factory-shipped default values (refer to Table D-1, “Initial settings, settings that can be saved/recalled, settings that can be backed up,” on page 259).

To clear the limit ranges, use the following command.

- **:CALC:COMP:CLE** on page 136

Selecting limit range designation method

You can select the designation method of the primary parameter limit ranges (BIN1 to BIN9) from the following three modes:

Mode	Description	
Absolute mode	Designation using the absolute value	
Absolute tolerance mode	Designation using the relative value (deviation from the reference value)	Designation using the absolute value ^{*1}
Percent tolerance mode		Designation using the percentage of the reference value ^{*2}

*1. Boundary value - reference value

*2. ((Boundary value - reference value)/reference value) × 100

NOTE

Only the absolute mode can be used as the designation method of the secondary parameter limit range.

To select the designation method, use the following command.

- **:CALC:COMP:MODE** on page 141

To set up the reference value for the absolute tolerance mode or percent tolerance mode, use the following command.

- **:CALC:COMP:PRIM:NOM** on page 144

Turning ON/OFF limit range

To turn ON/OFF the primary parameter limit range (BIN1 to BIN9), use the following command.

- **:CALC:COMP:PRIM:BIN{1-9}:STAT** on page 143

Only BINs set to ON with the above command become the targets of sorting judgment. In other words, even if the measured result falls within the limit range of a BIN set to OFF, it will not be sorted to that BIN.

To turn ON/OFF the secondary parameter limit range, use the following command.

- **:CALC:COMP:SEC:STAT** on page 146

If you specify OFF with the above command, no sorting judgment is made for the measured result of the secondary parameter. The comparator sorting judgment result is determined only on the basis of the measured primary parameter result.

Setting the range's lower and upper limit values

To set the lower limit value and upper limit value of the primary parameter limit range (BIN1 to BIN9), use the following command.

- **:CALC:COMP:PRIM:BIN{1-9}** on page 142

To set the lower limit value and upper limit value of the secondary parameter limit range, use the following command.

- **:CALC:COMP:SEC:LIM** on page 145

NOTE

If you set the upper limit value to a value equal to or less than the lower limit value, no limit range is used. Doing this would be equivalent to setting the limit range to OFF.

As shown in Figure 7-1, "Sorting judgment flow," on page 87, the sorting judgment is performed in increasing order of BIN number. Therefore, when the limit ranges of two BINs overlap, the result is sorted to the BIN with the smaller number.

For the tolerance mode, the reference value does not need to be within the limit range (between the lower limit value and upper limit value).

Gaps are allowed between the limit ranges.

Sorting Based on Measured Result (Comparator Function) Setting Up Comparator Function

Turning ON/OFF AUX BIN function

To turn ON/OFF the AUX BIN function, use the following command.

- **:CALC:COMP:AUXB** on page 135

Depending on the ON/OFF state of the AUX BIN function, the sorting result when the value of the secondary parameter exceeds the limit range varies as shown in Table 7-1.

Table 7-1

Sorting result when measured secondary parameter value exceeds limit range

Primary parameter sorting result	AUX BIN function	Sorting result
One of BIN1 to BIN9	OFF	OUT_OF_BINS
	ON	AUX_BIN
Not sorted to any BIN	Not applicable	OUT_OF_BINS

Setting up condition to make a beep sound

You can select the condition that produces a beep sound based on the comparator sorting judgment result from the following:

- Beep when the sorting judgment result is OUT_OF_BINS or AUX_BIN
- Beep when the sorting judgment result is BIN1 to BIN9

To set the condition that makes a beep sound, use the following command.

- **:CALC:COMP:BEEP:COND** on page 136

You can also disable the beep sound. To turn ON/OFF the beep, use either of the following commands (they have the same function).

- **:CALC:COMP:BEEP** on page 135
- **:SYST:BEEP:STAT** on page 191

Rejecting Excessively Low Measured Results (Low C reject function)

Turning ON/OFF Low C reject function

To turn ON/OFF the Low C reject function, use the following command.

- **:CREJ** on page 166

You can detect an excessively low (equal to or less than the preset boundary value) measured result of the primary parameter value (Cp or Cs) as Low C (abnormal measurement status) by turning ON the Low C reject function.

NOTE

When the comparator function is ON, the sorting judgment is performed normally even if Low C is detected. However, the sorting judgment result displayed on the screen is LOWC and, on the handler interface, the /LOW_C_REJECT signal becomes active (LOW) in addition to the sorting judgment signal.

Setting limit (range boundary values) of Low C reject function

To set the limit (boundary values of the range in which Low C is detected) of the Low C reject function, use the following command.

- **:CREJ:LIM** on page 167

Reading Out Sorting Judgment Result

You can read out the sorting judgment result (readout value) along with the measured result by the comparator function according to the correspondences in Figure 7-1. To do this, use the following commands.

- ***TRG** on page 128
- **:FETC?** on page 181
- **:READ?** on page 186

The comparator sorting result is read out as an integer between 0 and 11, as shown in the table below.

Table 7-2

Relationship between comparator sorting result and readout value

Readout value	Comparator sorting result
0	OUT_OF_BINS
1	BIN1
2	BIN2
3	BIN3
4	BIN4
5	BIN5
6	BIN6
7	BIN7
8	BIN8
9	BIN9
10	AUX_BIN
11	Cannot be sorted (an overload is detected).

To display the comparator sorting result in the left side of the instrument setup display area, use the following command to select the comparator sorting result display page (page number: 6).

- **:DISP:TEXT2:PAGE** on page 179

Figure 7-1

Sorting judgment flow

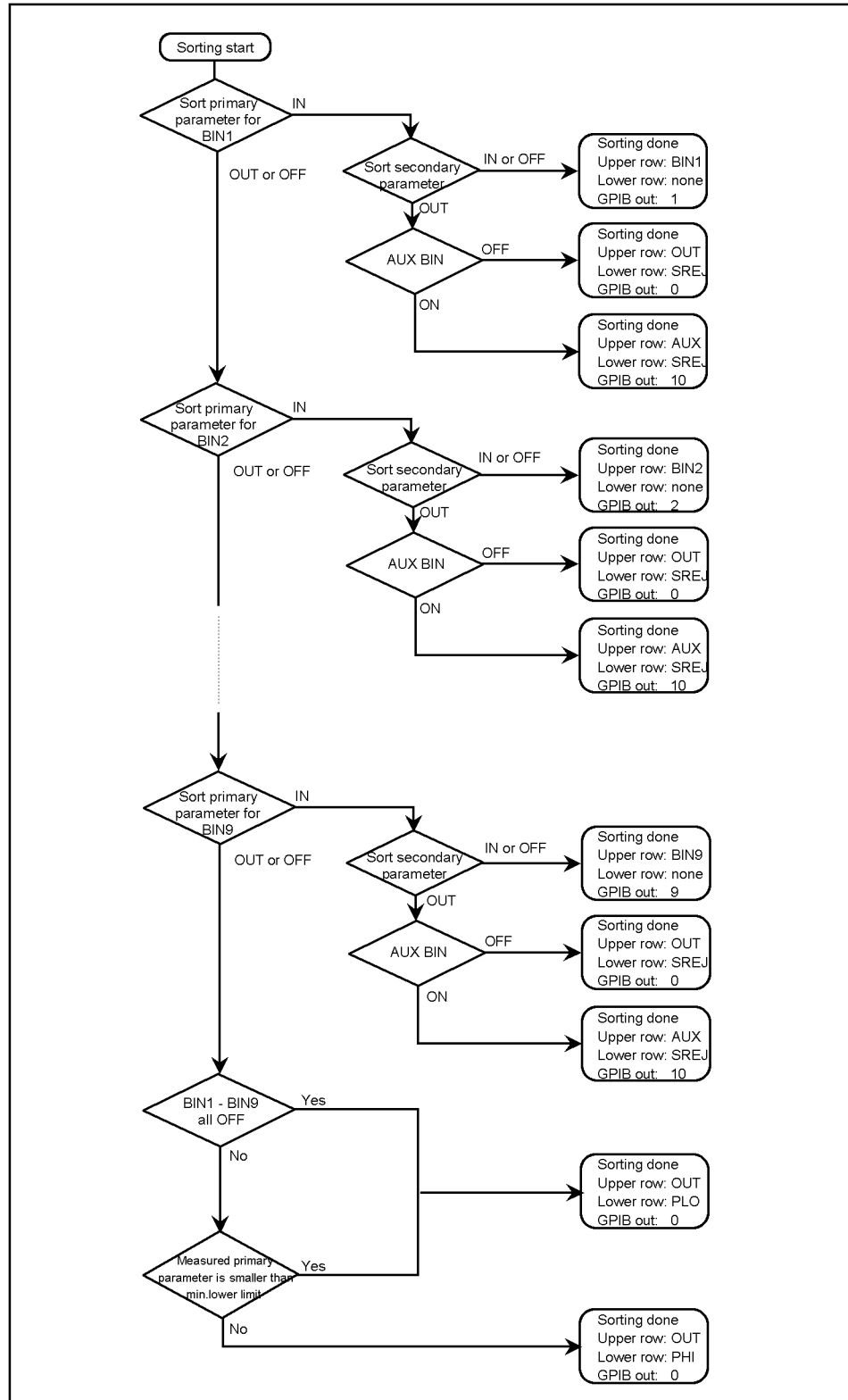

4288ace075

7. Sorting Based on Measured Result (Comparator Function)

Reading Out Sort Count Of Each Bin (BIN count function)

Turning ON/OFF BIN count function

To turn ON/OFF the BIN count function, use the following command.

- **:CALC:COMP:COUN** on page 137

You can count the number of DUTs sorted into each BIN by turning ON the BIN count function. The maximum value of the count is 999999. If this value is exceeded, the count does not continue to increase but remains at 999999 (does not return to 0).

When the MULTI compensation function is ON (set to ON with **:CORR:MULT** command on page 161), a channel-by-channel count is performed in addition to the normal count (total of all the channels).

Reading out BIN count value

To read out the BIN count value, use the following commands:

- **:CALC:COMP:COUN:DATA?** on page 138
- **:CALC:COMP:COUN:OVLD?** on page 140

To read out the BIN count value for each channel when the MULTI compensation function is ON, use the following commands:

- **:CALC:COMP:COUN:MULT:DATA?** on page 139
- **:CALC:COMP:COUN:MULT:OVLD?** on page 140

Clearing (resetting) the BIN count value

To clear all of the BIN count values (initialize to 0), use the following command.

- **:CALC:COMP:COUN:CLE** on page 137

Sample Program

Example 7-1 shows a sample program of the BIN sort function. This program is stored on the sample program disk under the filename “bin_sort.bas”.

This program sets up the limit ranges as shown in the below table, performs measurement 50 times, and then reads out and displays the measured result and comparator sorting result for each measurement. Then, it reads out and displays the sort count for each BIN after the completion of all measurements.

	Lower limit value	Upper limit value
BIN1	-1%	1%
BIN2	-2%	2%
BIN3	-3%	3%
Secondary parameter	0	0.1

The program is detailed below:

- Line 60 Sets the GPIB address.
- Lines 80 to 100 Assigns the settings of the primary parameter (Cp), secondary parameter (D), and measurement range (1 nF) to the Pri\$, Sec\$, and Range\$ variables, respectively.
- Lines 120 to 130 Assigns the limit range designation method (percent tolerance mode) and reference value (1 nF) to the Mode\$ and Nom variables, respectively.
- Lines 140 to 220 Assigns the lower limit values and upper limit values of BIN1 to BIN3 to the L_lim(*) and U_Lim(*) variables, respectively.
- Lines 230 to 250 Assigns the lower limit value and upper limit value of the secondary parameter limit range to the L_lim_sec and U_lim_sec variables, respectively.
- Lines 270 to 290 Assigns the ON/OFF state of the AUX BIN function, the ON/OFF state of the Low C reject function, and the limit (10%) to the Aux\$, Low_c_rej\$, and Low_c_rej_lim variables, respectively.
- Line 310 Resets the instrument.
- Lines 350 to 370 Sets the primary parameter, secondary parameter, and measurement range to Pri\$, Sec\$, and Range\$, respectively.
- Lines 410 to 420 Sets the limit range designation method and reference value to Mode\$ and Nom, respectively.
- Lines 430 to 460 Sets the lower limit values and upper limit values of BIN1 to BIN3 to L_lim(*) and U_Lim(*), respectively, and turns ON BIN1 to BIN3.
- Lines 470 to 490 Turns OFF BIN4 to BIN9.
- Lines 500 to 510 Sets the lower limit value and upper limit value of the secondary parameter limit range to L_lim_sec and U_Lim_sec, respectively, and turns ON the secondary parameter limit range.

7. Sorting Based on Measured Result (Comparator Function)

Sorting Based on Measured Result (Comparator Function)

Sample Program

- Lines 530 to 550 Sets the ON/OFF state of the AUX BIN function, the ON/OFF state of the Low C reject function, and the limit of the Low C reject function to Aux\$, Low_c_rej\$, and Low_c_rej_lim.
- Lines 560 to 570 Turns ON the comparator function and sets the instrument to display the comparator sorting result in the instrument setup display area.
- Line 610 Sets the trigger mode to the GPIB trigger.
- Lines 650 to 680 Turns ON the BIN count function and clears the count values.
- Lines 730 to 760 Sets the result display format to the Img\$ variable and displays the title section of the result display.
- Lines 770 to 810 Repeats 50 times the operation of triggering the instrument, reading out the measured result, and displaying the result according to the Img\$ format.
- Lines 820 to 850 Reads out the BIN count values.
- Lines 860 to 950 Displays the read out BIN count values.

Example 7-1

Sorting using comparator function (comprtr.bas)

```

10    DIM Pri$(9),Sec$(9),Range$(9),Mode$(9),Aux$(9),Low_c_rej$(9)
      ,Img$(50)
20    REAL Nom,L_lim(1:3),U_lim(1:3),L_lim_sec,U_lim_sec
30    REAL Low_c_rej_lim,Pri_para,Sec_para
40    INTEGER I,Meas_stat,Comp,Bin(1:11),Ovld
50    !
60    ASSIGN @Agt4288a TO 717
70    !
80    Pri$="CP"
90    Sec$="D"
100   Range$="1NF"
110   !
120   Mode$="PCNT"
130   Nom=1.E-9
140   !-- [BIN1] --
150   L_lim(1)=-1.0
160   U_lim(1)=1.0
170   !-- [BIN2] --
180   L_lim(2)=-2.0
190   U_lim(2)=2.0
200   !-- [BIN3] --
210   L_lim(3)=-3.0
220   U_lim(3)=3.0
230   !-- [Sec] --
240   L_lim_sec=0.
250   U_lim_sec=.1
260   !
270   Aux$="ON"
280   Low_c_rej$="ON"
290   Low_c_rej_lim=10.0
300   !
310   OUTPUT @Agt4288a;":SYST:PRES"
320   !
330   ! Measurement Condition Setting
340   !
350   OUTPUT @Agt4288a;":CALC1:FORM "&Pri$
360   OUTPUT @Agt4288a;":CALC2:FORM "&Sec$
370   OUTPUT @Agt4288a;":RANG "&Range$
380   !
390   ! Comparator Setting
400   !
410   OUTPUT @Agt4288a;":CALC:COMP:MODE "&Mode$
420   OUTPUT @Agt4288a;":CALC:COMP:PRIM:NOM " ;Nom
430   FOR I=1 TO 3
440     OUTPUT @Agt4288a;":CALC:COMP:PRIM:BIN"&VAL$(I)&" ";L_lim(I)
      ;",";U_lim(I)
450     OUTPUT @Agt4288a;":CALC:COMP:PRIM:BIN"&VAL$(I)&":STAT ON"
460   NEXT I
470   FOR I=4 TO 9
480     OUTPUT @Agt4288a;":CALC:COMP:PRIM:BIN"&VAL$(I)&":STAT OFF"
490   NEXT I
500   OUTPUT @Agt4288a;":CALC:COMP:SEC:LIM ";L_lim_sec;" ";U_lim_s
      ec
510   OUTPUT @Agt4288a;":CALC:COMP:SEC:STAT ON"
520   !

```

Sorting Based on Measured Result (Comparator Function) Sample Program

```
530  OUTPUT @Agt4288a;":CALC:COMP:AUXB "&Aux$
540  OUTPUT @Agt4288a;":CREJ "&Low_c_rej$
550  OUTPUT @Agt4288a;":CREJ:LIM ";Low_c_rej_lim
560  OUTPUT @Agt4288a;":CALC:COMP ON"
570  OUTPUT @Agt4288a;":DISP:TEXT2:PAGE 6"
580  !
590  ! Trigger setting
600  !
610  OUTPUT @Agt4288a;":TRIG:SOUR BUS"
620  !
630  ! Bin count setting
640  !
650  OUTPUT @Agt4288a;":CALC:COMP:COUN ON"
660  OUTPUT @Agt4288a;":CALC:COMP:COUN:CLE"
670  OUTPUT @Agt4288a;":*OPC?"
680  ENTER @Agt4288a;Buff$
690  !
700  ! Measurement
710  !
720  CLEAR SCREEN
730  Img$="3D,3X,D,4X,MD.4DE,2X,MD.4DE,2X,2D"
740  PRINT "[MEASUREMENT and BIN SORT RESULT]"
750  PRINT "      Status      "&Pri$&"          "&Sec$&"          BIN"
760  PRINT " -----"
770  FOR I=1 TO 50
780      OUTPUT @Agt4288a;":*TRG"
790      ENTER @Agt4288a;Meas_stat,Pri_para,Sec_para,Comp
800      PRINT USING Img$;I,Meas_stat,Pri_para,Sec_para,Comp
810  NEXT I
820  OUTPUT @Agt4288a;":CALC:COMP:COUN:DATA?"
830  ENTER @Agt4288a;Bin(*)
840  OUTPUT @Agt4288a;":CALC:COMP:COUN:OVLD?"
850  ENTER @Agt4288a;Ovld
860  Img$="2X,17A,5D"
870  PRINT "[BIN COUNT RESULT]"
880  PRINT "      BIN          Count"
890  PRINT " -----"
900  FOR I=1 TO 9
910      PRINT USING Img$;"BIN"&VAL$(I)&":",Bin(I)
920  NEXT I
930  PRINT USING Img$;"OUT OF BINS:",Bin(10)
940  PRINT USING Img$;"AUX BIN:",Bin(11)
950  PRINT USING Img$;"OVLD:",Ovld
960  !
970  END
```

8 **Avoiding Mistakes Related to Work and Daily Checks**

This chapter describes how to avoid simple mistakes related to work, how to detect the occurrence of an error, and how to execute the self-test.

Avoiding Mistakes Related To Work

Avoiding improper input from the front panel (key lock function)

When you do not need to operate the keys on the front panel, you can disable entry from the front panel keys (key lock function) to avoid improper input due to touching the front panel keys accidentally.

To turn ON/OFF the key lock function, use the following command.

- **:SYST:KLOC** on page 193

NOTE

If you lock the keys through GPIB, the **[Lcl]** key is disabled and you cannot clear the remote mode. Therefore, to clear the remote mode, you must first unlock the keys through GPIB.

Avoiding mistakes related to work when obtaining compensation data

By confirming that the data is measured properly, you can avoid careless mistakes related to work when measuring data for OPEN/SHORT/LOAD compensation (for example, setting up the OPEN state and SHORT state inversely).

For details, refer to “Avoiding work-related mistakes in measuring compensation data” on page 37.

Detecting the occurrence of an error

Using error queue

The error queue contains the error number and error message of an error that has occurred. By reading out the contents of the error queue, you can find out which error has occurred. To read out the contents of the error queue, use the following command.

- **:SYST:ERR?** on page 192

You can use the error queue in the following ways.

1. You can use it to make a branch for error handling in your program. When you read out the contents of the error queue, 0 and “No error” are read out as the error number and error message if no error has occurred. This result helps you to determine whether an error has occurred and to make the branch of your program’s flow. You can also use it to restrict error handling to the occurrence of a specific error. However, it is difficult to use this method to perform processing during the occurrence of an error.
2. You can use it to investigate the kind of error that has occurred when an error is detected by using SRQ and other means. Refer to the sample program in Example 8-1.

Using status report system

You can detect the status of the 4288A by using the status register. This section describes how to detect the occurrence of an error by using the status register. For information on the entire status report system (for example, information on each bit of the status register), refer to Appendix C, “Status Reporting System,” on page 247.

The occurrence of an error is indicated by the standard event status register. An SRQ (service request), which is useful for detecting the occurrence of an error in your program, uses the information indicated by this register.

To detect the end of sweep with an SRQ, use the following commands.

- ***SRE** on page 127
- ***ESE** on page 124

The procedure is given below.

- Step 1.** Set the 4288A to generate an SRQ if one of the error occurrence bits of the standard event status register is set to 1.
- Step 2.** Perform interrupt handling in the program when SRQ occurs.

Figure 8-1

SRQ generation sequence (when an error occurs)

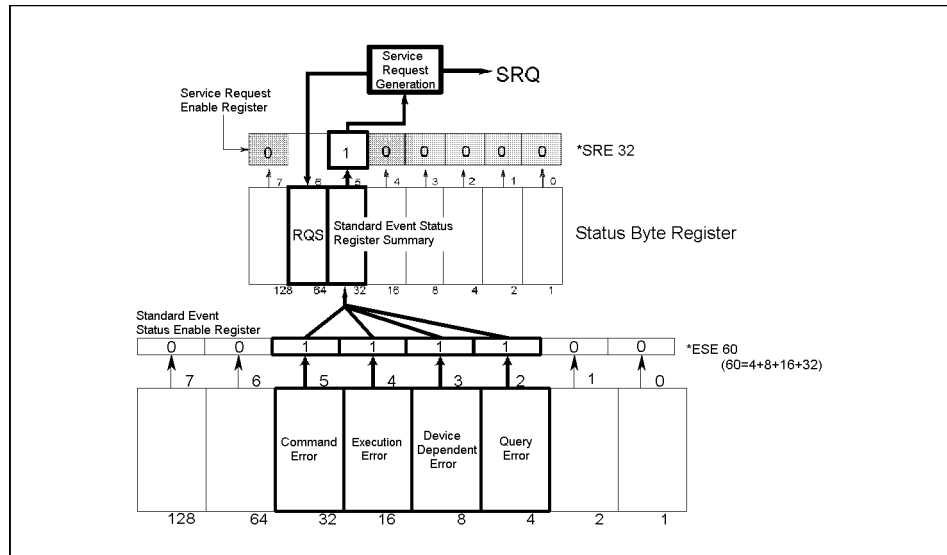

4288ape015

Sample program

Example 8-1 shows a sample program to detect the occurrence of an error using SRQ. This program is stored on the sample program disk under the filename “srq_err.bas”.

This program sets up SRQ, intentionally sends a nonexistent command for the 4288A to generate an error, and performs error handling. In the error handling, the program checks which error has occurred, displays the error number and error message, and displays the “PROGRAM INTERRUPT” message.

- Line 40 Sets the GPIB address.
- Lines 60 to 70 Enables bit 2, bit 3, bit 4, and bit 5 of the standard event status register and sets bit 5 of the service request enable register to 1.
- Lines 80 to 100 Clears the status byte register, standard event status register, and error queue.
- Lines 120 to 130 Sets the branch destination of the SRQ interrupt and enables SRQ interrupt.
- Lines 140 to 190 Selects the primary parameter and secondary parameter. However, because the command for the secondary parameter is wrong, an error occurs.
- Lines 220 to 230 Processing when an error occurs. Reads out the error number and error message of the error that has occurred.
- Lines 240 to 260 Displays the “Error occurred!!” message, error number, error message, and “PROGRAM INTERRUPT!!” message.
- Line 280 Displays the “PROGRAM DONE” Message. Notice that this message is not displayed unless you correct and execute the secondary parameter selection command.

Example 8-1

Error occurrence detection using SRQ (srq_err.bas)

```
10 DIM Buff$(9),Err_mes$(50)
20 INTEGER Err_no
30 !
40 ASSIGN @Agt4288a TO 717
50 !
60 OUTPUT @Agt4288a;"*ESE 60"
70 OUTPUT @Agt4288a;"*SRE 32"
80 OUTPUT @Agt4288a;"*CLS"
90 OUTPUT @Agt4288a;"*OPC?"
100 ENTER @Agt4288a;Buff$
110 !
120 ON INTR 7 GOTO Err_proc
130 ENABLE INTR 7;2
140 OUTPUT @Agt4288a;":CALC1:FORM CS"
150 PRINT "Primary Parameter Setting: Cs"
160 OUTPUT @Agt4288a;":CALC2:FOR Q"
170 PRINT "Secondary Parameter Setting: Q"
180 OUTPUT @Agt4288a;"*OPC?"
190 ENTER @Agt4288a;Buff$
200 GOTO Skip_err_proc
210 Err_proc: OFF INTR 7
220 OUTPUT @Agt4288a;";:SYST:ERR?"
230 ENTER @Agt4288a;Err_no,Err_mes$
240 PRINT "Error occurred!!"
250 PRINT " No: ";Err_no,"Description: "&Err_mes$
260 PRINT "PROGRAM INTERRUPT!!"
270 GOTO Prog_end
280 Skip_err_proc: PRINT "PROGRAM DONE."
290 Prog_end: END
```

Daily Checks (executing the self-test)

The 4288A has a self-test function that consists of an internal test and an external test.

Internal test

To execute the internal test, use the following command.

- ***TST?** on page 129

When you execute the above command, one of the error codes shown in Table 8-1 may be displayed after the completion of the test.

NOTE

If the instrument has passed all of the tests, 0 is read out. If several errors are detected simultaneously, the sum of their error numbers is read out.

Table 8-1 Self-test items

Test item	Description of test	Error code
RAM	Checks that the data bus of RAM is connected properly and there is no faulty memory cell.	1
Boot ROM	Checks that the checksum of the boot ROM is correct.	2
Flash ROM	Checks that the checksum of the flash ROM is correct.	4
Calibration data	Checks that the checksum of the calibration data (factory calibration data) in EEPROM is correct.	8
Compensation data	Checks that the checksum of the compensation data in EEPROM is correct. Even if the test fails, the compensation data is not initialized.	16
A/D converter	Checks that the A/D converter operates properly.	32
Backup RAM	Checks that the instrument setup values in backup memory (RAM) are proper. Even if the test fails, the instrument setup values are not initialized.	64

External test

To execute the external test, use the following command.

- **:SYST:TEST?** on page 194

NOTE

Before executing the command, connect the 42090A to the UNKNOWN terminal of the 4288A (or directly connect between L_{CUR} and L_{POT} and between H_{CUR} and H_{POT} with BNC cables).

Sample program

Example 8-1 shows a sample program to execute the self-test. This program is stored on the sample program disk under the filename “selftest.bas”.

This program executes the self-test and displays the result.

Line 30 Sets the GPIB address.

Lines 50 to 70 Executes the self-test and reads out the result.

Line 100 If the error code is 0, displays the “ALL TEST PASS” message.

Lines 120 to 320 If the error code is not 0, displays the test item that has failed.

Example 8-2

Executing the self-test (selftest.bas)

```
10     INTEGER Result
20     !
30     ASSIGN @Agt4288a TO 717
40     !
50     PRINT "Now testing..."
60     OUTPUT @Agt4288a;"*TST?"
70     ENTER @Agt4288a;Result
80     !
90     IF Result=0 THEN
100       PRINT "ALL TEST PASS"
110     ELSE
120       IF BIT(Result,0)=1 THEN
130          PRINT "TEST FAIL: RAM"
140       END IF
150       IF BIT(Result,1)=1 THEN
160          PRINT "TEST FAIL: Boot ROM"
170       END IF
180       IF BIT(Result,2)=1 THEN
190          PRINT "TEST FAIL: Flash ROM"
200       END IF
210       IF BIT(Result,3)=1 THEN
220          PRINT "TEST FAIL: Factory Cal. Data"
230       END IF
240       IF BIT(Result,4)=1 THEN
250          PRINT "TEST FAIL: Compensation Data"
260       END IF
270       IF BIT(Result,5)=1 THEN
280          PRINT "TEST FAIL: A/D Converter"
290       END IF
300       IF BIT(Result,6)=1 THEN
310          PRINT "TEST FAIL: Back-up RAM"
320       END IF
330     END IF
340     END
```

Avoiding Mistakes Related to Work and Daily Checks
Daily Checks (executing the self-test)

9 Measurement Applications (Sample Programs)

This chapter contains sample programs for both basic measurement and measurement using a system integrated with the handler/scanner interface.

Basic Capacitor Measurement

Example 9-1 shows a sample program to measure a capacitor using the test fixture. This program is stored on the sample program disk under the filename “meas_fxt.bas”.

This program performs measurement in the same way as the procedure given in Chapter 4 of the *Operation Manual*, in the section called “Learning Basic Measurement Procedure.” When you start this program, the message “Connect Test Fixture, then Push [Enter] key” is displayed. Connect the test fixture suitable for the shape of the capacitor you want to measure to the Agilent 4288A and press the **[Enter]** key.

“Set Open-Connection” is displayed. Bring the test fixture to the state for OPEN measurement and press the **[y]** key and **[Enter]** key in this order. The OPEN compensation data is measured. Then, “Set Short-Connection” is displayed. Measure the SHORT compensation data in the same way.

NOTE

For how to use the test fixture (for example, the states for the OPEN/SHORT measurement), refer to the operation manual of the test fixture.

When measurement of the compensation data is finished, “Set DUT, then Push [Enter] key” is displayed. Attach a capacitor to the test fixture and then press the **[Enter]** key. The measurement is performed and the result is displayed.

After the result is displayed, “Once more? [Y]es/[N]o” is displayed. If you want to make the measurement again or measure another DUT, press the **[y]** key and **[Enter]** key in this order. If you want to finish measurement, press any key other than the **[y]** key and **[Enter]** key in this order.

The program is detailed below.

Line 60	Sets the GPIB address.
Lines 80 to 120	Assigns the setups of the primary parameter (Cp), secondary parameter (Q), measurement signal frequency (1 MHz), measurement signal level (0.5 V), and cable length (0 m) to the Pri\$, Sec\$, Freq, Lvl, and Cbl variables, respectively.
Lines 140 to 150	Prompts the user to connect the test fixture and waits for the user to press the [Enter] key after the connection.
Line 170	Resets the instrument.
Lines 190 to 230	Sets the primary parameter, secondary parameter, measurement signal frequency, measurement signal level, and cable length to Pri\$, Sec\$, Freq, Lvl, and Cbl.
Lines 250 to 280	Uses the FNCompen sub-program to measure OPEN/SHORT compensation data. For the FNCompen sub-program, refer to the description in Example 4-1 on page 40.
Lines 300 to 310	Sets the trigger mode to the GPIB trigger and turns ON the trigger system successive startup.
Lines 340 to 350	Prompts the user to connect the DUT and waits for the user to press the [Enter] key after the connection.
Lines 360 to 370	Triggers the instrument and reads out the measured result.

- Lines 410 to 480 Displays the measured result.
- Lines 500 to 510 Prompts the user to enter decision on whether to make the measurement again. If the user presses the **[y]** and **[Enter]** keys, returns to the DUT connection stage and repeats the measurement.

Example 9-1

Capacitor measurement using test fixture (meas_fxt.bas)

```

10 DIM Pri$(9),Sec$(9),Inp_char$(9)
20 REAL Freq,Lvl,Pri_res,Sec_res
30 INTEGER Cbl,Result,Meas_stat
40 CLEAR SCREEN
50 !
60 ASSIGN @Agt4288a TO 717
70 !
80 Pri$="CP"
90 Sec$="Q"
100 Freq=1.E+6
110 Lvl=.5
120 Cbl=0
130 !
140 PRINT "Connect Test Fixture, then Push [Enter] key"
150 INPUT "",Inp_char$
160 !
170 OUTPUT @Agt4288a;" :SYST:PRES"
180 !
190 OUTPUT @Agt4288a;" :CALC1:FORM ";Pri$
200 OUTPUT @Agt4288a;" :CALC2:FORM ";Sec$
210 OUTPUT @Agt4288a;" :SOUR:FREQ ";Freq
220 OUTPUT @Agt4288a;" :SOUR:VOLT ";Lvl
230 OUTPUT @Agt4288a;" :CAL:CABL ";Cbl
240 !
250 Result=FNCompen(@Agt4288a,"Open",.00002)
260 IF Result<>0 THEN Prog_end
270 Result=FNCompen(@Agt4288a,"Short",20)
280 IF Result<>0 THEN Prog_end
290 !
300 OUTPUT @Agt4288a;" :TRIG:SOUR BUS"
310 OUTPUT @Agt4288a;" :INIT:CONT ON"
320 !
330 Meas_start: !
340 PRINT "Set DUT, then Push [Enter] key"
350 INPUT "",Inp_char$
360 OUTPUT @Agt4288a;"*TRG"
370 ENTER @Agt4288a;Meas_stat,Pri_res,Sec_res
380 !
390 ! Display results
400 !
410 PRINT "[MEASUREMENT RESULT]"
420 IF Meas_stat=1 THEN
430 PRINT USING "X,3A,6A";Pri$," : OVLD"
440 PRINT USING "X,3A,6A";Sec$," : OVLD"
450 ELSE
460 PRINT USING "X,3A,A,X,SD.5DE";Pri$," :",Pri_res
470 PRINT USING "X,3A,A,X,SD.5DE";Sec$," :",Sec_res
480 END IF
490 !
500 INPUT "Once more? [Y]es/[N]o",Inp_char$
510 IF UPC$(Inp_char$)="Y" OR UPC$(Inp_char$)="YES" THEN Meas_start
520 !
530 Prog_end: END
540 !=====
550 ! Compensation Data Measurement Function

```

Measurement Applications (Sample Programs)

Basic Capacitor Measurement

```

560      !=====
570 DEF FNCompen(@Agt4288a,Standard$,Limit)
580   DIM Inp_char$[9],Buff$[9],Std$[9],Err$[50]
590   REAL Curr_freq,Freq(1:2),Para1,Para2,Zm,Ym,Gm,Bm
600   REAL Cpref,Dref,Zref,Gref,Bref
610   INTEGER Err_flag
620   OUTPUT @Agt4288a;":SOUR:FREQ?"
630   ENTER @Agt4288a;Curr_freq
640   Freq(1)=1.E+3
650   Freq(2)=1.E+6
660   Load_para$="CPD"
670   OUTPUT @Agt4288a;":STAT:OPER:ENAB 128"
680   OUTPUT @Agt4288a;"*SRE 128"
690   SELECT Standard$
700     CASE "Open"
710       Std$="STAN1"
720     CASE "Short"
730       Std$="STAN2"
740     CASE "Load"
750       Std$="STAN3"
760       CALL Inp_data("Load(Cp) Value @1kHz",Load1(1))
770       CALL Inp_data("Load(D) Value @1kHz",Load2(1))
780       CALL Inp_data("Load(Cp) Value @1MHz",Load1(2))
790       CALL Inp_data("Load(D) Value @1MHz",Load2(2))
800       OUTPUT @Agt4288a;":CORR:CKIT:STAN3:FORM "&Load_para$
810       FOR I=1 TO 2
820         OUTPUT @Agt4288a;":SOUR:FREQ ";Freq(I)
830         OUTPUT @Agt4288a;":CORR:CKIT:STAN3 ";Load1(I);",";Load2(I)
840       NEXT I
850     END SELECT
860   Compen_meas: !
870   PRINT "Set "&Standard$&"-Connection."
880   INPUT "OK? [Y/N]",Inp_char$
890   IF UPC$(Inp_char$)="Y" THEN
900     FOR I=1 TO 2
910       PRINT "Frequency: ";Freq(I)
920       OUTPUT @Agt4288a;":SOUR:FREQ ";Freq(I)
930       OUTPUT @Agt4288a;"*CLS"
940       OUTPUT @Agt4288a;"*OPC?"
950       ENTER @Agt4288a;Buff$
960       ! Measurement
970       ON INTR 7 GOTO Meas_end
980       ENABLE INTR 7;2
990       OUTPUT @Agt4288a;":CORR:COLL "&Std$
1000   Meas_wait: GOTO Meas_wait
1010   Meas_end: OFF INTR 7
1020     ! Error Check
1030     OUTPUT @Agt4288a;":SYST:ERR?"
1040     ENTER @Agt4288a;Err_no,Err$
1050     IF Err_no<>0 THEN
1060       PRINT "Error: "&Err$
1070       GOTO Compen_meas
1080     END IF
1090     ! Data Check
1100     OUTPUT @Agt4288a;":CORR:DATA? "&Std$
1110     ENTER @Agt4288a;Para1,Para2
1120     Err_flag=0
1130     SELECT Standard$
1140       CASE "Open"
1150         Ym=SQRT(Para1*Para1+Para2*Para2)
1160         PRINT "G = ";Para1,"B = ";Para2,"|Y| = ";Ym
1170         IF Ym>=Limit THEN Err_flag=1
1180       CASE "Short"
1190         Zm=SQRT(Para1*Para1+Para2*Para2)

```



```

1200         PRINT "R =" ; Para1, "X =" ; Para2, " |Z| =" ; Zm
1210         IF Zm >= Limit THEN Err_flag = 1
1220         CASE "Load"
1230             OUTPUT @Agt4288a; ":CORR:CKIT:STAN3?"
1240             ENTER @Agt4288a; Cpref, Dref
1250             Bref = 2*PI*Freq(I)*Cpref
1260             Gref = Bref*Dref
1270             Zref = 1/SQRT(Gref*Gref+Bref*Bref)
1280             Bm = 2*PI*Freq(I)*Para1
1290             Gm = Bm*Para2
1300             Zm = 1/SQRT(Gm*Gm+Bm*Bm)
1310             PRINT "Cpref=" ; Cpref, "Dref=" ; Dref, " |Zref| =" ; Zref
1320             PRINT "Cp =" ; Para1, "D =" ; Para2, " |Z| =" ; Zm
1330             IF ABS((Zm-Zref)/Zref) >= Limit THEN Err_flag = 1
1340         END SELECT
1350         IF Err_flag <> 0 THEN
1360             PRINT "Out of limit!!"
1370             GOTO Compen_meas
1380         END IF
1390     NEXT I
1400     PRINT Standard$ & " Data Measurement Complete"
1410     OUTPUT @Agt4288a; ":SOUR:FREQ "; Curr_freq
1420     RETURN 0
1430 ELSE
1440     PRINT "Program Interruption"
1450     OUTPUT @Agt4288a; ":SOUR:FREQ "; Curr_freq
1460     RETURN -1
1470 END IF
1480 FNEND
1490 !=====
1500 ! Data Input Function
1510 !=====
1520 SUB Inp_data(Mes$, Inp_val)
1530     DIM Inp_char$(30)
1540     ON ERROR GOTO Inp_start
1550 Inp_start:
1560     PRINT "Input "&Mes$
1570     INPUT "Value?", Inp_char$
1580     Inp_val = VAL(UPC$(Inp_char$))
1590     PRINT "Input Value: "; Inp_val
1600     INPUT "OK? [Y/N]", Inp_char$
1610     IF UPC$(Inp_char$) <> "Y" THEN Inp_start
1620     OFF ERROR
1630 SUBEND

```

Measurement with Auto-sorting System

Example 9-2 shows a sample program to measure a capacitor (1 nF), assuming that it is used in the auto-sorting system integrated with the handler. This program is stored on the sample program disk under the filename “meas_sys.bas”.

Prepare the auto-sorting system and then start the program. “Set Open-Connection” is displayed. Bring the measurement terminal of the system (for example, contact probe) to the OPEN state and press the **[y]** key and **[Enter]** key in this order. The OPEN compensation data is measured. Then, “Set Short-Connection” is displayed. Bring the measurement terminal of the system to the SHORT state and press the **[y]** key and **[Enter]** key in this order. The SHORT compensation data is measured.

Then, “Input Load(Cp) Value @1kHz” is displayed. According to the on-screen instructions, enter the Cp value of the LOAD standard (pre-valued working standard) at 1 kHz. In the same way, enter the D value at 1 kHz and the Cp and D values at 1 MHz.

When you finish defining the LOAD standard values, “Set Load-Connection” is displayed. Connect the working standard to the measurement terminal and press the **[y]** key and **[Enter]** key in this order. The LOAD compensation data is measured.

When measurement of the compensation data is finished, “Set Dut, then input external trigger!” is displayed. Connect the DUT to the measurement terminal in the auto-sorting system and enter an external trigger signal from the handler interface. When the measurement finishes, the sorting judgment result for the BIN setup (see table below), measurement status, and measured primary and secondary parameter values are displayed. Repeat this operation 10 times.

	Lower limit value	Upper limit value
BIN1	-1%	1%
BIN2	-2%	2%
BIN3	-3%	3%
Secondary parameter	0	0.1

When all 10 measurements are finished, the counts sorted to each BIN are displayed and the program finishes.

The program is detailed below.

Line 70	Sets the GPIB address.
Line 90	Assigns the number of measurements (10 times) into the Max_meas variable.
Lines 110 to 160	Assigns the setups of the primary parameter (Cp), secondary parameter (D), measurement signal frequency (1 kHz), measurement signal level (1 V), measurement time mode (short), and cable length (1 m) to the Pri\$, Sec\$, Freq, Lvl, Meas_time\$, and Cbl variables, respectively.
Lines 180 to 190	Assigns the limit range designation method (percent tolerance mode) and reference value (1 nF) to the Mode\$ and Nom variables, respectively.
Lines 200 to 280	Assigns the lower limit values and upper limit values of BIN1 to BIN3 to the L_lim(*) and U_Lim(*) variables, respectively.
Lines 290 to 310	Assigns the lower limit value and upper limit value of the secondary parameter limit range to the L_lim_sec and U_lim_sec variables, respectively.
Lines 320 to 340	Assigns the ON/OFF state of the AUX BIN function, ON/OFF state of the Low C reject function, and limit (10%) to the Aux\$, Low_c_rej\$, and Low_c_rej_lim variables, respectively.
Line 360	Resets the instrument.
Lines 370 to 420	Sets the primary parameter, secondary parameter, measurement signal frequency, measurement signal level, measurement time mode, and cable length to Pri\$, Sec\$, Freq, Lvl, Meas_time\$, and Cbl, respectively.
Lines 440 to 460	Turns OFF the measured result display and beep output and locks the front panel keys.
Lines 500 to 550	Uses the FNCompen sub-program to measure OPEN/SHORT/LOAD compensation data. For the FNCompen sub-program, refer to the description in Example 4-1 on page 40.
Line 570	Sets the measurement range to Nom.
Lines 610 to 620	Sets the limit range designation method and reference value to Mode\$ and Nom, respectively.
Lines 630 to 660	Sets the lower limit values and upper limit values of BIN1 to BIN3 to L_lim(*) and U_Lim(*), respectively, and turns ON BIN1 to BIN3.
Lines 670 to 690	Turns OFF BIN4 to BIN9.
Lines 700 to 710	Sets the lower limit value and upper limit value of the secondary parameter limit range to L_lim_sec and U_Lim_sec, respectively, and turns ON the secondary parameter limit range.
Lines 730 to 750	Sets the ON/OFF state of the AUX BIN function, the ON/OFF state of the Low C reject function, and the limit of the Low C reject function to Aux\$, Low_c_rej\$, and Low_c_rej_lim, respectively.
Line 760	Turns ON the comparator function.

Measurement Applications (Sample Programs)

Measurement with Auto-sorting System

- Lines 800 to 810 Sets the trigger mode to the external trigger and turns ON the trigger system successive startup.
- Lines 850 to 880 Turns ON the BIN count function and clears the count values.
- Lines 920 to 930 Sets the instrument to generate an SRQ when measurement finishes and clears the status byte register and operation status event register.
- Lines 950 to 1160 Repeats the following Max_meas times.
1. Lines 960 to 990: Waits for the trigger system to make the transition to the trigger wait state.
 2. Lines 1000 to 1020: Clears the status byte register and operation status event register.
 3. Lines 1030 to 1040: Sets the branch destination of the SRQ interrupt and enables SRQ interrupt.
 4. Lines 1050 to 1060: Displays the message to prompt the user to connect the DUT and enter an external trigger and then waits until the external trigger is inputted and the measurement is finished.

NOTE

In this example, the status report system is employed to synchronize with the instrument state of the 4288A. For the auto-sorting system using the handler, you can also use handler interface output signals such as /READY_FOR_TRIG, /INDEX, and /EOM for synchronization.

5. Lines 1070 to 1150: Reads out the measurement status, measured primary and secondary parameter values, and comparator sorting result and displays them.

NOTE

For the auto-sorting system integrated with the handler, you can also use the handler interface output signals /BIN1 to /BIN9, /OUT_OF_BINS, and /AUX_BIN to obtain the comparator sorting result and /OVLd and /LOW_C_REJECT to obtain the measurement status (overload and Low C occurrence).

Lines 1180 to 1300 Reads out the BIN count values and displays them.

Example 9-2

Measurement assuming auto-sorting system (meas_sys.bas)

```
10 DIM Pri$(9),Sec$(9),Mode$(9),Aux$(9),Meas_time$(9),Low_c_rej$(9)
20 REAL Freq,Lvl,Nom,Low_c_rej_lim
30 REAL L_lim(1:3),U_lim(1:3),L_lim_sec,U_lim_sec,Pri_res,Sec_res
40 INTEGER Max_meas,Cbl,Result,Meas_stat,Comp,Bin(1:11),Ovld,I
50 CLEAR SCREEN
60 !
70 ASSIGN @Agt4288a TO 717
80 !
90 Max_meas=10
100 !
110 Pri$="CP"
120 Sec$="D"
130 Freq=1.E+3
140 Lvl=1.0
150 Meas_time$="SHOR"
```

```

160 Cbl=1
170 !
180 Mode$="PCNT"
190 Nom=1.E-9
200 !-- [BIN1] --
210 L_lim(1)=-1.0
220 U_lim(1)=1.0
230 !-- [BIN2] --
240 L_lim(2)=-2.0
250 U_lim(2)=2.0
260 !-- [BIN3] --
270 L_lim(3)=-3.0
280 U_lim(3)=3.0
290 !-- [Sec] --
300 L_lim_sec=0.
310 U_lim_sec=.1
320 Aux$="ON"
330 Low_c_rej$="ON"
340 Low_c_rej_lim=10.0
350 !
360 OUTPUT @Agt4288a;"*RST"
370 OUTPUT @Agt4288a;"CALC1:FORM ";Pri$
380 OUTPUT @Agt4288a;"CALC2:FORM ";Sec$
390 OUTPUT @Agt4288a;"SOUR:FREQ ";Freq
400 OUTPUT @Agt4288a;"SOUR:VOLT ";Lvl
410 OUTPUT @Agt4288a;"APER "&Meas_time$
420 OUTPUT @Agt4288a;"CAL:CABL ";Cbl
430 !
440 OUTPUT @Agt4288a;"DISP OFF"
450 OUTPUT @Agt4288a;"SYST:BEEP:STAT OFF"
460 OUTPUT @Agt4288a;"SYST:KLOC ON"
470 !
480 ! Compensation
490 !
500 Result=FNCompen(@Agt4288a,"Open",.00002)
510 IF Result<>0 THEN Prog_end
520 Result=FNCompen(@Agt4288a,"Short",20)
530 IF Result<>0 THEN Prog_end
540 Result=FNCompen(@Agt4288a,"Load",20)
550 IF Result<>0 THEN Prog_end
560 !
570 OUTPUT @Agt4288a;"RANG ";Nom
580 !
590 ! Comparator Setting
600 !
610 OUTPUT @Agt4288a;"CALC:COMP:MODE "&Mode$
620 OUTPUT @Agt4288a;"CALC:COMP:PRIM:NOM ";Nom
630 FOR I=1 TO 3
640 OUTPUT @Agt4288a;"CALC:COMP:PRIM:BIN"&VAL$(I)&" ";L_lim(I);", "
;U_lim(I)
650 OUTPUT @Agt4288a;"CALC:COMP:PRIM:BIN"&VAL$(I)&" :STAT ON"
660 NEXT I
670 FOR I=4 TO 9
680 OUTPUT @Agt4288a;"CALC:COMP:PRIM:BIN"&VAL$(I)&" :STAT OFF"
690 NEXT I
700 OUTPUT @Agt4288a;"CALC:COMP:SEC:LIM ";L_lim_sec;",";U_lim_sec
710 OUTPUT @Agt4288a;"CALC:COMP:SEC:STAT ON"
720 !
730 OUTPUT @Agt4288a;"CALC:COMP:AUXB ON"
740 OUTPUT @Agt4288a;"CREJ "&Low_c_rej$
750 OUTPUT @Agt4288a;"CREJ:LIM ";Low_c_rej_lim
760 OUTPUT @Agt4288a;"CALC:COMP ON"
770 !
780 ! Trigger setting

```

Measurement Applications (Sample Programs)

Measurement with Auto-sorting System

```

790      !
800      OUTPUT @Agt4288a;":TRIG:SOUR EXT"
810      OUTPUT @Agt4288a;":INIT:CONT ON"
820      !
830      ! Bin count setting
840      !
850      OUTPUT @Agt4288a;":CALC:COMP:COUN ON"
860      OUTPUT @Agt4288a;":CALC:COMP:COUN:CLE"
870      OUTPUT @Agt4288a;"*OPC?"
880      ENTER @Agt4288a;Buff$
890      !
900      ! SRQ setting
910      !
920      OUTPUT @Agt4288a;":STAT:OPER:ENAB 16"
930      OUTPUT @Agt4288a;"*SRE 128"
940      !
950      FOR I=1 TO Max_meas
960          REPEAT
970              OUTPUT @Agt4288a;":STAT:OPER:COND?"
980              ENTER @Agt4288a;Cond_reg
990              UNTIL BIT(Cond_reg,5)
1000             OUTPUT @Agt4288a;"*CLS"
1010             OUTPUT @Agt4288a;"*OPC?"
1020             ENTER @Agt4288a;Buff$
1030             ON INTR 7 GOTO Meas_end
1040             ENABLE INTR 7;2
1050             PRINT "Set DUT, then input external trigger!"
1060 Meas_wait: GOTO Meas_wait
1070 Meas_end: OFF INTR 7
1080             OUTPUT @Agt4288a;":FETC?"
1090             ENTER @Agt4288a;Meas_stat,Pri_res,Sec_res,Comp
1100             !
1110             PRINT "[MEASUREMENT RESULT]"
1120             PRINT USING "X,7A,X,2D";"BIN      :",Comp
1130             PRINT USING "X,7A,X,2D";"STATUS:",Meas_stat
1140             PRINT USING "X,6A,A,X,SD.5DE";Pri$,":",Pri_res
1150             PRINT USING "X,6A,A,X,SD.5DE";Sec$,":",Sec_res
1160         NEXT I
1170         !
1180         OUTPUT @Agt4288a;":CALC:COMP:COUN:DATA?"
1190         ENTER @Agt4288a;Bin(*)
1200         OUTPUT @Agt4288a;":CALC:COMP:COUN:OVLD?"
1210         ENTER @Agt4288a;Ovld
1220         PRINT "[BIN COUNT RESULT]"
1230         PRINT "      BIN              Count"
1240         PRINT " -----"
1250         FOR I=1 TO 3
1260             PRINT USING "2X,17A,5D";"BIN"&VAL$(I)&":",Bin(I)
1270         NEXT I
1280         PRINT USING "2X,17A,5D";"OUT OF BINS:",Bin(10)
1290         PRINT USING "2X,17A,5D";"AUX BIN:",Bin(11)
1300         PRINT USING "2X,17A,5D";"OVLD:",Ovld
1310         !
1320 Prog_end: END
1330      !=====
1340      ! Compensation Data Measurement Function
1350      !=====
1360 DEF FNCompen(@Agt4288a,Standard$,Limit)
1370     DIM Inp_char$(9),Buff$(9),Std$(9),Err$(50)
1380     REAL Curr_freq,Freq(1:2),Para1,Para2,Zm,Ym,Gm,Bm
1390     REAL Cpref,Dref,Zref,Gref,Bref
1400     INTEGER Err_flag
1410     OUTPUT @Agt4288a;":SOUR:FREQ?"
1420     ENTER @Agt4288a;Curr_freq

```

```

1430 Freq(1)=1.E+3
1440 Freq(2)=1.E+6
1450 Load_para$="CPD"
1460 OUTPUT @Agt4288a;" :STAT:OPER:ENAB 128"
1470 OUTPUT @Agt4288a;"*SRE 128"
1480 SELECT Standard$
1490 CASE "Open"
1500 Std$="STAN1"
1510 CASE "Short"
1520 Std$="STAN2"
1530 CASE "Load"
1540 Std$="STAN3"
1550 CALL Inp_data("Load(Cp) Value @1kHz",Load1(1))
1560 CALL Inp_data("Load(D) Value @1kHz",Load2(1))
1570 CALL Inp_data("Load(Cp) Value @1MHz",Load1(2))
1580 CALL Inp_data("Load(D) Value @1MHz",Load2(2))
1590 OUTPUT @Agt4288a;" :CORR:CKIT:STAN3:FORM "&Load_para$
1600 FOR I=1 TO 2
1610 OUTPUT @Agt4288a;" :SOUR:FREQ ";Freq(I)
1620 OUTPUT @Agt4288a;" :CORR:CKIT:STAN3 ";Load1(I);",";Load2(I)
1630 NEXT I
1640 END SELECT
1650 Compen_meas: !
1660 PRINT "Set "&Standard$&"-Connection."
1670 INPUT "OK? [Y/N]",Inp_char$
1680 IF UPC$(Inp_char$)="Y" THEN
1690 FOR I=1 TO 2
1700 PRINT "Frequency:";Freq(I)
1710 OUTPUT @Agt4288a;" :SOUR:FREQ ";Freq(I)
1720 OUTPUT @Agt4288a;"*CLS"
1730 OUTPUT @Agt4288a;"*OPC?"
1740 ENTER @Agt4288a;Buff$
1750 ! Measurement
1760 ON INTR 7 GOTO Meas_end
1770 ENABLE INTR 7;2
1780 OUTPUT @Agt4288a;" :CORR:COLL "&Std$
1790 Meas_wait: GOTO Meas_wait
1800 Meas_end: OFF INTR 7
1810 ! Error Check
1820 OUTPUT @Agt4288a;" :SYST:ERR?"
1830 ENTER @Agt4288a;Err_no,Err$
1840 IF Err_no<>0 THEN
1850 PRINT "Error: "&Err$
1860 GOTO Compen_meas
1870 END IF
1880 ! Data Check
1890 OUTPUT @Agt4288a;" :CORR:DATA? "&Std$
1900 ENTER @Agt4288a;Para1,Para2
1910 Err_flag=0
1920 SELECT Standard$
1930 CASE "Open"
1940 Ym=SQRT(Para1*Para1+Para2*Para2)
1950 PRINT "G =" ;Para1,"B =" ;Para2," |Y| =" ;Ym
1960 IF Ym>=Limit THEN Err_flag=1
1970 CASE "Short"
1980 Zm=SQRT(Para1*Para1+Para2*Para2)
1990 PRINT "R =" ;Para1,"X =" ;Para2," |Z| =" ;Zm
2000 IF Zm>=Limit THEN Err_flag=1
2010 CASE "Load"
2020 OUTPUT @Agt4288a;" :CORR:CKIT:STAN3?"
2030 ENTER @Agt4288a;Cpref,Dref
2040 Bref=2*PI*Freq(I)*Cpref
2050 Gref=Bref*Dref
2060 Zref=1/SQRT(Gref*Gref+Bref*Bref)

```

Measurement Applications (Sample Programs)

Measurement with Auto-sorting System

```
2070          Bm=2*PI*Freq(I)*Paral
2080          Gm=Bm*Para2
2090          Zm=1/SQRT(Gm*Gm+Bm*Bm)
2100          PRINT "Cpref=";Cpref,"Dref=";Dref,"|Zref|=";Zref
2110          PRINT "Cp   =";Paral,"D   =";Para2,"|Z|   =";Zm
2120          IF ABS((Zm-Zref)/Zref)>=Limit THEN Err_flag=1
2130      END SELECT
2140      IF Err_flag<>0 THEN
2150          PRINT "Out of limit!!"
2160          GOTO Compen_meas
2170      END IF
2180  NEXT I
2190  PRINT Standard$&" Data Measurement Complete"
2200  OUTPUT @Agt4288a;" :SOUR:FREQ ";Curr_freq
2210  RETURN 0
2220 ELSE
2230     PRINT "Program Interruption"
2240     OUTPUT @Agt4288a;" :SOUR:FREQ ";Curr_freq
2250     RETURN -1
2260 END IF
2270 FNEED
2280 !=====
2290 ! Data Input Function
2300 !=====
2310 SUB Inp_data(Mes$,Inp_val)
2320   DIM Inp_char$(30)
2330   ON ERROR GOTO Inp_start
2340 Inp_start: !
2350   PRINT "Input "&Mes$
2360   INPUT "Value?",Inp_char$
2370   Inp_val=VAL(UPC$(Inp_char$))
2380   PRINT "Input Value: ";Inp_val
2390   INPUT "OK? [Y/N]",Inp_char$
2400   IF UPC$(Inp_char$)<>"Y" THEN Inp_start
2410   OFF ERROR
2420 SUBEND
```

Measurement with changing channels (scanning)

Example 9-3 shows a sample program to measure a capacitor (1 nF) that is used in a four-channel scanning system. This program is stored on the sample program disk under the filename “meas_scn.bas”.

Prepare the scanning system and then start the program. “Set the Scanner's Channel to No.0, and Set Open-Connection” is displayed. Set the channel of the scanner in the system to No. 0, bring the measurement terminal of channel 0 (for example, a contact probe) to the OPEN state, and press the **[y]** key and **[Enter]** key in this order. The OPEN compensation data for channel 0 is measured. In the same way, measure the OPEN compensation data for channels 1 to 3.

When measurement of the OPEN compensation data for all of the channels is finished, “Set the Scanner's Channel to No.0, and Set Short-Connection” is displayed. Set the channel of the scanner in the system to No. 0, bring the measurement terminal of channel 0 to the SHORT state, and press the **[y]** key and **[Enter]** key in this order. The SHORT compensation data for channel 0 is measured. In the same way, measure the SHORT compensation data for channels 1 to 3.

When measurement of the SHORT compensation data for all of the channels is finished, “Set the Scanner's Channel to No.0, and Input Load(Cp) Value @1kHz” is displayed. Set the channel of the scanner in the system to No. 0. According to the on-screen instructions, enter the Cp value of the LOAD standard (pre-valued working standard) for channel 0 at 1 kHz. In the same way, enter the D value at 1 kHz and the Cp and D values at 1 MHz. When you finish defining the LOAD standard values, “Set Load-Connection” is displayed. Connect the working standard to the measurement terminal of channel 0 and press the **[y]** key and **[Enter]** key in this order. The LOAD compensation data for channel 0 is measured. In the same way, measure the LOAD compensation data for channels 1 to 3.

When the measurement of the compensation data is finished, “Set DUT of All Channels. Set the Scanner's Channel to No.0. Input External Trigger!” is displayed. Connect the DUTs to the measurement terminals of all channels, set the channel of the scanner to No. 0, and then input an external trigger signal from the scanner (or handler) interface. The measurement is performed. In the same way, perform measurement for channels 1 to 3. When measurement for all the channels is finished, the sorting judgment result for the BIN setup (see table below), measurement status, and measured primary and secondary parameter values for all of the channels are displayed at the same time. Repeat this operation 10 times.

	Lower limit value	Upper limit value
BIN1	-1%	1%
BIN2	-2%	2%
BIN3	-3%	3%
Secondary parameter	0	0.1

When the 10 measurements for each channel (total 40 times) are finished, the counts sorted to each BIN for each channel are displayed and the program finishes.

Measurement Applications (Sample Programs)

Measurement with changing channels (scanning)

The program is detailed below.

- Lines 80 to 90 Sets the GPIB address.
- Lines 110 to 120 Assigns the number of measurements (10 times) and maximum channel number to the Max_meas and Max_chan variables, respectively
- Lines 140 to 190 Assigns the setups of the primary parameter (Cp), secondary parameter (D), measurement signal frequency (1 kHz), measurement signal level (1 V), measurement time mode (short), and cable length (1 m) to the Pri\$, Sec\$, Freq, Lvl, Meas_time\$, and Cbl variables, respectively.
- Lines 210 to 220 Assigns the limit range designation method (percent tolerance mode) and reference value (1 nF) to the Mode\$ and Nom variables, respectively.
- Lines 230 to 310 Assigns the lower limit values and upper limit values of BIN1 to BIN3 to the L_lim(*) and U_Lim(*) variables, respectively.
- Lines 320 to 340 Assigns the lower limit value and upper limit value of the secondary parameter limit range to the L_lim_sec and U_lim_sec variables, respectively.
- Lines 350 to 370 Assigns the ON/OFF state of the AUX BIN function, the ON/OFF state of the Low C reject function, and the limit (10%) to the Aux\$, Low_c_rej\$, and Low_c_rej_lim variables, respectively.
- Line 390 Resets the instrument.
- Lines 400 to 450 Sets the primary parameter, secondary parameter, measurement signal frequency, measurement signal level, measurement time mode, and cable length to Pri\$, Sec\$, Freq, Lvl, Meas_time\$, and Cbl, respectively.
- Lines 470 to 480 Turns ON the MULTI compensation function and specifies the channel-by-channel definition for the LOAD compensation standard value.
- Line 490 Sets the instrument to display the setup of the MULTI compensation function in the instrument setup display area.
- Lines 510 to 520 Turns OFF the beep sound output and locks the front panel keys.
- Lines 560 to 760 Uses the FNCompen sub-program to measure the OPEN/SHORT/LOAD compensation data for all of the channels (0 to 3). For the FNCompen sub-program, refer to the description in Example 4-1 on page 40.
- Line 780 Sets the measurement range to Nom.
- Lines 820 to 830 Sets the limit range designation method and reference value to Mode\$ and Nom, respectively.
- Lines 840 to 870 Sets the lower limit values and upper limit values of BIN1 to BIN3 to L_lim(*) and U_Lim(*) respectively and turns ON BIN1 to BIN3.
- Lines 880 to 900 Turns OFF BIN4 to BIN9.
- Lines 910 to 920 Sets the lower limit value and upper limit value of the secondary parameter limit range to L_lim_sec and U_Lim_sec, respectively, and

- turns ON the secondary parameter limit range.
- Lines 940 to 960 Sets the ON/OFF state of the AUX BIN function, the ON/OFF state of the Low C reject function, and the limit of the Low C reject function to Aux\$, Low_c_rej\$, and Low_c_rej_lim, respectively.
- Line 970 Turns ON the comparator function.
- Lines 1010 to 1020 Sets the trigger mode to the external trigger and turns ON the trigger system successive startup.
- Lines 1060 to 1090 Turns ON the BIN count function and clears the count values.
- Lines 1130 to 1140 Sets the instrument to generate an SRQ when measurement is finished and clears the status byte register and operation status event register.
- Lines 1180 to 1190 Sets the number of measurements to be fed into the data buffer to 4 and sets the instrument to feed the measured result to the data buffer.
- Line 1200 Sets the data transfer format to the binary format.
- Lines 1220 to 1530 Repeats the following procedures the number of times equivalent to Max_meas.
1. Line 1230: Displays the message to prompt the user to connect the DUTs to all channels.
 2. Lines 1250 to 1360: Repeats the following for all channels (0 to Max_chan) in the order of channel number.
 - a. Line 1260: Sets the channel of the 4288A.
 - b. Lines 1270 to 1290: Clears the status byte register and operation status event register.
 - c. Lines 1300 to 1310: Sets the branch destination of the SRQ interrupt and enables the SRQ interrupt.
 - d. Lines 1320 to 1340: Displays the message to prompt the user to connect the DUT and enter an external trigger and then waits until the external trigger is inputted and the measurement is finished.
 3. Lines 1380 to 1440: Reads out the measurement status, measured primary and secondary parameter values, and comparator sorting result for all of the channels at one time by using data buffer 3.
 4. Lines 1460 to 1520: Displays the measurement status, measured primary and secondary parameter values, and comparator sorting result for all channels.
- Lines 1550 to 1660 Reads out the BIN count values for each channel and displays them.

NOTE

In this example, the GPIB command is used to set the channel of the 4288A. When using the scanner interface, you can also use the input signals /CH0 to /CH5 and /CH_VALID to set the channel.

Measurement Applications (Sample Programs)

Measurement with changing channels (scanning)

Example 9-3

Scanning measurement (meas_scn.bas)

```
10 DIM Pri$(9),Sec$(9),Mode$(9),Aux$(9),Meas_time$(9),Low_c_rej$(9)
20 DIM Digit$(1),Read_form$(9),Num_of_byte$(9),Buff$(9),Img$(50)
30 REAL Freq,Lvl,Data(0:3,1:4),Nom,Low_c_rej_lim
40 REAL L_lim(1:3),U_lim(1:3),L_lim_sec,U_lim_sec,Pri_res,Sec_res
50 INTEGER Max_meas,Max_chan,Cbl,Result,Ch,Bin(1:11),Ovld,I
60 CLEAR SCREEN
70 !
80 ASSIGN @Binary TO 717;FORMAT OFF
90 ASSIGN @Agt4288a TO 717
100 !
110 Max_meas=10
120 Max_chan=3
130 !
140 Pri$="CP"
150 Sec$="D"
160 Freq=1.E+3
170 Lvl=1.0
180 Meas_time$="SHOR"
190 Cbl=1
200 !
210 Mode$="PCNT"
220 Nom=1.E-9
230 !-- [BIN1] --
240 L_lim(1)=-1.0
250 U_lim(1)=1.0
260 !-- [BIN2] --
270 L_lim(2)=-2.0
280 U_lim(2)=2.0
290 !-- [BIN3] --
300 L_lim(3)=-3.0
310 U_lim(3)=3.0
320 !-- [Sec] --
330 L_lim_sec=0.
340 U_lim_sec=.1
350 Aux$="ON"
360 Low_c_rej$="ON"
370 Low_c_rej_lim=10.0
380 !
390 OUTPUT @Agt4288a;"*RST"
400 OUTPUT @Agt4288a;"CALC1:FORM ";Pri$
410 OUTPUT @Agt4288a;"CALC2:FORM ";Sec$
420 OUTPUT @Agt4288a;"SOUR:FREQ ";Freq
430 OUTPUT @Agt4288a;"SOUR:VOLT ";Lvl
440 OUTPUT @Agt4288a;"APER "&Meas_time$
450 OUTPUT @Agt4288a;"CAL:CABL ";Cbl
460 !
470 OUTPUT @Agt4288a;"CORR:MULT ON"
480 OUTPUT @Agt4288a;"CORR:MULT:CKIT:STAN3 ON"
490 OUTPUT @Agt4288a;"DISP:TEXT2:PAGE 5"
500 !
510 OUTPUT @Agt4288a;"SYST:BEEP:STAT OFF"
520 OUTPUT @Agt4288a;"SYST:KLOC ON"
530 !
540 ! Compensation
550 !
560 PRINT "##### Open Data Measurement #####"
570 FOR Ch=0 TO Max_chan
580 OUTPUT @Agt4288a;"CORR:MULT:CHAN ";Ch
590 PRINT "Set the Scanner's Channel to No."&VAL$(Ch)&", and"
600 Result=FNCompen(@Agt4288a,"Open",.00002)
610 IF Result<>0 THEN Prog_end
```

Measurement Applications (Sample Programs)
Measurement with changing channels (scanning)

```
620 NEXT Ch
630 PRINT "##### Short Data Measurement #####"
640 FOR Ch=0 TO Max_chan
650     OUTPUT @Agt4288a;":CORR:MULT:CHAN ";Ch
660     PRINT "Set the Scanner's Channel to No."&VAL$(Ch)&", and"
670     Result=FNCompen(@Agt4288a,"Short",20)
680     IF Result<>0 THEN Prog_end
690 NEXT Ch
700 PRINT "##### Load Data Measurement #####"
710 FOR Ch=0 TO Max_chan
720     OUTPUT @Agt4288a;":CORR:MULT:CHAN ";Ch
730     PRINT "Set the Scanner's Channel to No."&VAL$(Ch)&", and"
740     Result=FNCompen(@Agt4288a,"Load",.2)
750     IF Result<>0 THEN Prog_end
760 NEXT Ch
770 !
780 OUTPUT @Agt4288a;":RANG ";Nom
790 !
800 ! Comparator Setting
810 !
820 OUTPUT @Agt4288a;":CALC:COMP:MODE "&Mode$
830 OUTPUT @Agt4288a;":CALC:COMP:PRIM:NOM ";Nom
840 FOR I=1 TO 3
850     OUTPUT @Agt4288a;":CALC:COMP:PRIM:BIN"&VAL$(I)&" ";L_lim(I);","
;U_lim(I)
860     OUTPUT @Agt4288a;":CALC:COMP:PRIM:BIN"&VAL$(I)&":STAT ON"
870 NEXT I
880 FOR I=4 TO 9
890     OUTPUT @Agt4288a;":CALC:COMP:PRIM:BIN"&VAL$(I)&":STAT OFF"
900 NEXT I
910 OUTPUT @Agt4288a;":CALC:COMP:SEC:LIM ";L_lim_sec;",";U_lim_sec
920 OUTPUT @Agt4288a;":CALC:COMP:SEC:STAT ON"
930 !
940 OUTPUT @Agt4288a;":CALC:COMP:AUXB "&Aux$
950 OUTPUT @Agt4288a;":CREJ "&Low_c_rej$
960 OUTPUT @Agt4288a;":CREJ:LIM ";Low_c_rej_lim
970 OUTPUT @Agt4288a;":CALC:COMP ON"
980 !
990 ! Trigger setting
1000 !
1010 OUTPUT @Agt4288a;":TRIG:SOUR EXT"
1020 OUTPUT @Agt4288a;":INIT:CONT ON"
1030 !
1040 ! Bin count setting
1050 !
1060 OUTPUT @Agt4288a;":CALC:COMP:COUN ON"
1070 OUTPUT @Agt4288a;":CALC:COMP:COUN:CLE"
1080 OUTPUT @Agt4288a;":*OPC?"
1090 ENTER @Agt4288a;Buff$
1100 !
1110 ! SRQ setting
1120 !
1130 OUTPUT @Agt4288a;":STAT:OPER:ENAB 16"
1140 OUTPUT @Agt4288a;":*SRE 128"
1150 !
1160 ! Data buffer setting
1170 !
1180 OUTPUT @Agt4288a;":DATA:POIN BUF3,";Max_chan+1
1190 OUTPUT @Agt4288a;":DATA:FEED:CONT BUF3,ALW"
1200 OUTPUT @Agt4288a;":FORM REAL"
1210 !
1220 FOR I=1 TO Max_meas
1230     PRINT "Set DUT of All Channels."
1240     !
```

Measurement Applications (Sample Programs)

Measurement with changing channels (scanning)

```

1250     FOR Ch=0 TO Max_chan
1260         OUTPUT @Agt4288a;" :CORR:MULT:CHAN ";Ch
1270         OUTPUT @Agt4288a;"*CLS"
1280         OUTPUT @Agt4288a;"*OPC?"
1290         ENTER @Agt4288a;Buff$
1300         ON INTR 7 GOTO Meas_end
1310         ENABLE INTR 7;2
1320         PRINT "Set the Scanner's Channel to No."&VAL$(Ch)&". "
1330         PRINT "Input External Trigger!"
1340 Meas_wait: GOTO Meas_wait
1350 Meas_end: OFF INTR 7
1360     NEXT Ch
1370     !
1380     OUTPUT @Agt4288a;" :DATA? BUF3"
1390     ENTER @Agt4288a USING "#,A";Buff$
1400     ENTER @Agt4288a USING "#,A";Digit$
1410     Read_form$="#,&Digit$&"A"
1420     ENTER @Agt4288a USING Read_form$;Num_of_byte$
1430     ENTER @Binary;Data(*)
1440     ENTER @Agt4288a USING "#,A";Buff$
1450     !
1460     Img$=" 2X, 2D, 7X, D, 3X, SD. 5DE, 2X, SD. 5DE, 2X, 2D"
1470     PRINT "[MEASUREMENT RESULT]"
1480     PRINT "CH No.  STATUS          "&Pri$&"          "&Sec$&"          BI
N"
1490     PRINT "-----"
1500     FOR Ch=0 TO Max_chan
1510         PRINT USING Img$;Ch,Data(Ch,1),Data(Ch,2),Data(Ch,3),Data(Ch,4)
1520     NEXT Ch
1530 NEXT I
1540 !
1550 Img$=" 2X, 2D, 3X, 5D, 3X, 5D, 3X, 5D, 3X, 5D, 3X, 5D, 3X, 5D"
1560 PRINT "[BIN COUNT RESULT]"
1570 PRINT "CH No.  BIN1    BIN2    BIN3    OUT    AUX    OVLD"
1580 PRINT "-----"
1590 FOR Ch=0 TO Max_chan
1600     OUTPUT @Agt4288a;" :CORR:MULT:CHAN ";Ch
1610     OUTPUT @Agt4288a;" :CALC:COMP:COUN:MULT:DATA?"
1620     ENTER @Agt4288a;Bin(*)
1630     OUTPUT @Agt4288a;" :CALC:COMP:COUN:MULT:OVLD?"
1640     ENTER @Agt4288a;Ovld
1650     PRINT USING Img$;Ch,Bin(1),Bin(2),Bin(3),Bin(10),Bin(11),Ovld
1660 NEXT Ch
1670 !
1680 Prog_end: END
1690 !=====
1700 ! Compensation Data Measurement Function
1710 !=====
1720 DEF FNCompen(@Agt4288a,Standard$,Limit)
1730 DIM Inp_char$(9),Buff$(9),Std$(9),Err$(50)
1740 REAL Curr_freq,Freq(1:2),Para1,Para2,Zm,Ym,Gm,Bm
1750 REAL Cpref,Dref,Zref,Gref,Bref
1760 INTEGER Err_flag
1770 OUTPUT @Agt4288a;" :SOUR:FREQ?"
1780 ENTER @Agt4288a;Curr_freq
1790 Freq(1)=1.E+3
1800 Freq(2)=1.E+6
1810 Load_para$="CPD"
1820 OUTPUT @Agt4288a;" :STAT:OPER:ENAB 128"
1830 OUTPUT @Agt4288a;"*SRE 128"
1840 SELECT Standard$
1850     CASE "Open"
1860         Std$="STAN1"
1870     CASE "Short"

```

Measurement Applications (Sample Programs)
Measurement with changing channels (scanning)

```

1880     Std$="STAN2"
1890 CASE "Load"
1900     Std$="STAN3"
1910     CALL Inp_data("Load(Cp) Value @1kHz",Load1(1))
1920     CALL Inp_data("Load(D) Value @1kHz",Load2(1))
1930     CALL Inp_data("Load(Cp) Value @1MHz",Load1(2))
1940     CALL Inp_data("Load(D) Value @1MHz",Load2(2))
1950     OUTPUT @Agt4288a;":CORR:CKIT:STAN3:FORM "&Load_para$
1960     FOR I=1 TO 2
1970         OUTPUT @Agt4288a;":SOUR:FREQ ";Freq(I)
1980         OUTPUT @Agt4288a;":CORR:CKIT:STAN3 ";Load1(I);",";Load2(I)
1990     NEXT I
2000 END SELECT
2010 Compen_meas: !
2020 PRINT "Set "&Standard$&"-Connection."
2030 INPUT "OK? [Y/N]",Inp_char$
2040 IF UPC$(Inp_char$)="Y" THEN
2050     FOR I=1 TO 2
2060         PRINT "Frequency: ";Freq(I)
2070         OUTPUT @Agt4288a;":SOUR:FREQ ";Freq(I)
2080         OUTPUT @Agt4288a;"*CLS"
2090         OUTPUT @Agt4288a;"*OPC?"
2100         ENTER @Agt4288a;Buff$
2110         ! Measurement
2120         ON INTR 7 GOTO Meas_end
2130         ENABLE INTR 7;2
2140         OUTPUT @Agt4288a;":CORR:COLL "&Std$
2150 Meas_wait: GOTO Meas_wait
2160 Meas_end: OFF INTR 7
2170         ! Error Check
2180         OUTPUT @Agt4288a;":SYST:ERR?"
2190         ENTER @Agt4288a;Err_no,Err$
2200         IF Err_no<>0 THEN
2210             PRINT "Error: "&Err$
2220             GOTO Compen_meas
2230         END IF
2240         ! Data Check
2250         OUTPUT @Agt4288a;":CORR:DATA? "&Std$
2260         ENTER @Agt4288a;Para1,Para2
2270         Err_flag=0
2280         SELECT Standard$
2290             CASE "Open"
2300                 Ym=SQRT(Para1*Para1+Para2*Para2)
2310                 PRINT "G =";Para1,"B =";Para2,"|Y| =" ;Ym
2320                 IF Ym>=Limit THEN Err_flag=1
2330             CASE "Short"
2340                 Zm=SQRT(Para1*Para1+Para2*Para2)
2350                 PRINT "R =";Para1,"X =";Para2,"|Z| =" ;Zm
2360                 IF Zm>=Limit THEN Err_flag=1
2370             CASE "Load"
2380                 OUTPUT @Agt4288a;":CORR:CKIT:STAN3?"
2390                 ENTER @Agt4288a;Cpref,Dref
2400                 Bref=2*PI*Freq(I)*Cpref
2410                 Gref=Bref*Dref
2420                 Zref=1/SQRT(Gref*Gref+Bref*Bref)
2430                 Bm=2*PI*Freq(I)*Para1
2440                 Gm=Bm*Para2
2450                 Zm=1/SQRT(Gm*Gm+Bm*Bm)
2460                 PRINT "Cpref=" ;Cpref,"Dref=" ;Dref,"|Zref| =" ;Zref
2470                 PRINT "Cp =" ;Para1,"D =" ;Para2,"|Z| =" ;Zm
2480                 IF ABS((Zm-Zref)/Zref)>=Limit THEN Err_flag=1
2490             END SELECT
2500         IF Err_flag<>0 THEN
2510             PRINT "Out of limit!!"

```

Measurement Applications (Sample Programs)

Measurement with changing channels (scanning)

```
2520         GOTO Compen_meas
2530         END IF
2540     NEXT I
2550     PRINT Standard$&" Data Measurement Complete"
2560     OUTPUT @Agt4288a;" :SOUR:FREQ ";Curr_freq
2570     RETURN 0
2580 ELSE
2590     PRINT "Program Interruption"
2600     OUTPUT @Agt4288a;" :SOUR:FREQ ";Curr_freq
2610     RETURN -1
2620 END IF
2630 FNEED
2640 !=====
2650 ! Data Input Function
2660 !=====
2670 SUB Inp_data(Mes$,Inp_val)
2680     DIM Inp_char$(30)
2690     ON ERROR GOTO Inp_start
2700     Inp_start: !
2710     PRINT "Input "&Mes$
2720     INPUT "Value?",Inp_char$
2730     Inp_val=VAL(UPC$(Inp_char$))
2740     PRINT "Input Value: ";Inp_val
2750     INPUT "OK? [Y/N]",Inp_char$
2760     IF UPC$(Inp_char$)<>"Y" THEN Inp_start
2770     OFF ERROR
2780 SUBEND
```

10 Command Reference

This chapter provides the GPIB command reference for the Agilent 4288A. Each command is fully described and ordered alphabetically based on its abbreviated name format. Use the index to look up a GPIB command by its full syntax. To find a command according to its function, refer to the “GPIB Command Table” on page 197.

Notational conventions in this command reference

This section describes the conventions used in the descriptions of the commands listed in this chapter.

Syntax

The section under the heading “Syntax” describes the syntax used to send the command from the external controller to the 4288A. A syntax consists of a command part and a parameter part, and the separator between these parts is a space.

If there are several parameters, the separator between adjacent parameters is a comma (,). An ellipsis (...) between commas indicates that parameters in that part are omitted. For example, <numeric 1>,...,<numeric 4> indicates that four parameters, <numeric 1>, <numeric 2>, <numeric 3>, and <numeric 4>, are required. String-type parameters, for example, <string>, <string 1>, must be enclosed in double quotation marks (“”).

You can omit the lowercase letters in syntax. For example, “:CALibration:CABLe” can be shortened to “:CAL:CABL.”

The symbols used in the syntax are defined as follows:

- < > Characters enclosed in this pair of symbols are necessary parameters when sending the command.
- [] The part enclosed in a pair of brackets can be omitted.
- { } A pair of braces indicates that you must select one of the items in this part. Individual items are separated by a pipe (|).

For example, “:APER SHOR,” “:SENS:FIMP:APERTURE:MODE LONG,” are valid for the syntax given below.

Syntax

```
[ :SENSe ] [ :FIMPedance ] :APERTure [ :MODE ] { SHORt | LONG }
```

Description

The section under the heading “Description” describes how to use the command or the operation when executed.

Parameters

The section under the heading “Parameters” describes the necessary parameters when sending the command. When a parameter is a value type or a string type enclosed by < > symbols, its description, allowable setup range, initial (factory-set) value, and so on are given; when a parameter is a selection type enclosed by { } symbols, a description of each selection item is given.

For a value-type parameter denoted with “MAX or MIN can be used,” you can use MAX (or MAXIMUM) and MIN (or MINIMUM) as the parameter instead of a value. These specify the maximum value and minimum value within the allowable setup range.

Query response

The section under the heading “Query response” describes the data format read out when query (reading out data) is available with the command.

Each readout parameter is enclosed with { } symbols. If there are several items within { } separated by a pipe (|), only one of them is read out.

When several parameters are read out, they are separated with a comma (,). An ellipsis (...) between commas indicate that the data of that part is omitted. For example, {numeric 1},..., {numeric 4} indicates that 4 data items, {numeric 1}, {numeric 2}, {numeric 3}, and {numeric 4}, are read out.

<newline><^END> after the parameters is the program message terminator.

Related commands

The section under the heading “Related commands” lists other commands associated with the current command.

Equivalent key sequence

The section under the heading “Equivalent key sequence” shows the operational procedure of the front panel keys that has the same effect as the command.

- | | |
|-----------------------|--|
| [Key] | Indicates the hardkey whose key label is Key. |
| [Blue] - [Key] | Indicates that you press the blue shift key to activate the shift function (2nd function printed in blue) and then press the hardkey whose key label (printed in dark gray) is Key. |
| [Key] - Item | Indicates a series of key operations in which you press the [Key] key, make the item called Item on the displayed menu blink by using the [↵] key or other means, and then press the [Enter] key. |

IEEE Common Commands

This section describes the IEEE common commands.

***CLS**

Syntax

*CLS

Description

Clears the following. (No query)

- Error Queue
- Status Byte Register
- Standard Event Status Register
- Operation Status Event Register
- Questionable Status Event Register

Equivalent key sequence

No equivalent key is available on the front panel.

***ESE**

Syntax

*ESE <numeric>

*ESE?

Description

Sets the value of the Standard Event Status Enable Register.

Parameters

	<numeric>
Description	Setup value of the register
Range	0 to 255
Initial value	0
Resolution	1

If the specified parameter is out of the allowable setup range, the result of bitwise AND with 255 (0xff) is set.

Query response

{numeric}<newline><^END>

Related commands

*SRE on page 127

Equivalent key sequence

No equivalent key is available on the front panel.

*ESR?

Syntax	*ESR?
Description	Reads out the value of the Standard Event Status Register. Executing this command clears the register value. (Query only)
Query response	{numeric}<newline><^END>
Equivalent key sequence	No equivalent key is available on the front panel.

*IDN?

Syntax	*IDN?								
Description	Reads out the product information (manufacturer, model number, serial number, and firmware version number) of the 4288A. (Query only)								
Query response	{string 1},{string 2},{string 3},{string 4}<newline><^END> Readout data is as follows: <table> <tr> <td>{string 1}</td> <td>Manufacturer. Agilent Technologies is always read out.</td> </tr> <tr> <td>{string 2}</td> <td>Model number. 4288A is always read out.</td> </tr> <tr> <td>{string 3}</td> <td>10-digit serial number (example: JP1KH00101).</td> </tr> <tr> <td>{string 4}</td> <td>Firmware version number (example: 01.00).</td> </tr> </table>	{string 1}	Manufacturer. Agilent Technologies is always read out.	{string 2}	Model number. 4288A is always read out.	{string 3}	10-digit serial number (example: JP1KH00101).	{string 4}	Firmware version number (example: 01.00).
{string 1}	Manufacturer. Agilent Technologies is always read out.								
{string 2}	Model number. 4288A is always read out.								
{string 3}	10-digit serial number (example: JP1KH00101).								
{string 4}	Firmware version number (example: 01.00).								
Equivalent key sequence	[Config]([Blue] - [-]) - Rev								

*OPC

Syntax	*OPC
Description	Sets the OPC bit (bit 0) of the Standard Event Status Register at the completion of all pending operations. (No query)
Equivalent key sequence	No equivalent key is available on the front panel.

*OPC?

Syntax	*OPC?
Description	1 is read out at the completion of all pending operations. (Query only)
Query response	{1}<newline><^END>
Equivalent key sequence	No equivalent key is available on the front panel.

Command Reference

*OPT?

*OPT?

Syntax	*OPT?
Description	Reads out the identification number of an option installed in the 4288A. (Query only)
Query response	{ numeric }<newline><^END> If there is no installed option, 0 is read out.
Equivalent key sequence	[Config] ([Blue] - [-]) - Rev

*RCL

Syntax	*RCL <numeric>
Description	Recalls the instrument setups saved in the register of the specified number on EEPROM. For details of recalled instrument setups, refer to Appendix D, “Initial Settings.” (No query)
Parameters	

	<numeric>
Description	Specified number
Range	0 to 9
Resolution	1

If the specified parameter is out of the allowable setup range, an error occurs.

Related commands	*SAV on page 127
Equivalent key sequence	[Rcl]
	*RST
Syntax	*RST
Description	Resets the instrument to the preset state. The preset state is different from that when resetting is done using the :SYST:PRES command. For details, refer to Appendix D, “Initial Settings.” (No query)
Related commands	:SYST:PRES on page 193 :INIT:CONT on page 183
Equivalent key sequence	No equivalent key is available on the front panel.

*SAV

Syntax *SAV <numeric>

Description Saves the instrument setups to the register of the specified number on EEPROM. For details of saved instrument setups, refer to Appendix D, “Initial Settings.” (No query)

Parameters

	<numeric>
Description	Specified number
Range	0 to 9
Resolution	1

If the specified parameter is out of the allowable setup range, an error occurs.

Related commands *RCL on page 126

Equivalent key sequence **[Save]**(**[Blue]** - **[Rcl]**)

*SRE

Syntax *SRE <numeric>

*SRE?

Description Sets the value of the Service Request Enable Register.

Parameters

	<numeric>
Description	Setup value of the register
Range	0 to 255
Initial value	0
Resolution	1

If the specified parameter is out of the allowable setup range, the result of bitwise AND with 255 (0xff) is set. Note that bit 6 cannot be set to 1.

Query response {numeric}<newline><^END>

Related commands *ESE on page 124
:STAT:OPER:ENAB on page 189

Equivalent key sequence No equivalent key is available on the front panel.

Command Reference

*STB?

*STB?

Syntax	*STB?
Description	Reads out the value of the Status Byte Register. (Query only)
Query response	{ numeric }<newline><^END>
Equivalent key sequence	No equivalent key is available on the front panel.

*TRG

Syntax	*TRG
Description	<p>If the trigger source is set to GPIB (set to BUS with the (:TRIG:SOUR command), triggers the 4288A as it waits for a trigger and reads out the measured data after the measurement is completed.</p> <p>The transfer format of data read out with this command conforms to the setup of the :FORM command.</p>

NOTE Although this command does not have "?", query response is given.

Query response	It is the same as that of the :FETC? command. For details, refer to the description of :FETC?.
Related commands	:FETC? on page 181 :TRIG:SOUR on page 196 :FORM on page 182
Equivalent key sequence	No equivalent key is available on the front panel.

*TST?

Syntax *TST?

Description Executes the self-test consisting of the following items and reads out the result. (Query only)

Table 10-1 Self-test Items

Test item	Test description	Error code
RAM	Verifies that the RAM data bus is connected correctly and there is no faulty memory cell.	1
Boot ROM	Verifies that the checksum of Boot ROM is correct.	2
Flash ROM	Verifies that the checksum of Flash ROM is correct.	4
Calibration data	Verifies that the checksum of the calibration data in the EEPROM (Factory Calibration Data) is correct.	8
Compensation data	Verifies that the checksum of the compensation data in the EEPROM is correct. Even if the test fails, the compensation data is not initialized.	16
A/D converter	Verifies that the board ID of the A/D converter operates normally.	32
Backup RAM	Verifies that the instrument setting value in the backup memory (RAM) is correct. Even if the test fails, the instrument setting value is not initialized.	64

Query response {numeric}<newline><^END>

The readout data is the sum of the error codes of failed tests. If no error has occurred, 0 is read out.

Related commands :SYST:TEST? on page 194

Equivalent key sequence **[Config]([Blue] - [-]) - Test - Internal**

*WAI

Syntax *WAI

Description Waits until all commands sent before this command are executed. (No query)

Equivalent key sequence No equivalent key is available on the front panel.

4288A GPIB Commands

This section describes the GPIB commands of the 4288A.

:ABOR

Syntax :ABORt

Description Resets the trigger system and places the trigger sequence in the idle state.
If the trigger system is set to start up successively (ON is specified with the **:INIT:CONT** command), the trigger system starts up immediately after the transition to the idle state.
For details on the trigger system, refer to “Trigger system” on page 52. (No query)

Related commands :INIT on page 183
:INIT:CONT on page 183

Equivalent key sequence No equivalent key is available on the front panel.

:APER

Syntax [:SENSe][:FIMPedance]:APERture[:MODE] {SHORT|LONG}
[:SENSe][:FIMPedance]:APERture[:MODE]?

Description Selects the measurement time (integral time) mode.
For information on the specific measurement time of each mode, see “Specification and Supplemental Performance Characteristics” in the *Operation Manual*.

Parameters

	Description
SHORT (initial value)	Specifies the short mode.
LONG	Specifies the long mode.

Query response {SHOR|LONG}<newline><^END>

Equivalent key sequence **[Meas Time]**

:AVER

Syntax [:SENSe]:AVERage[:STATe] {ON|OFF|1|0}
[:SENSe]:AVERage[:STATe]?

Description Turns ON/OFF the averaging function.

Parameters

	Description
ON or 1 (initial value)	Turns ON the averaging function.
OFF or 0	Turns OFF the averaging function.

Query response {1|0}<newline><^END>

Related commands :AVER:COUN on page 132

Equivalent key sequence **[Average]([Blue] - [Meas Time])**

NOTE You cannot turn ON/OFF the averaging function directly by using the front panel keys. Setting the averaging count with the front panel keys will automatically turn on the function. Note that after the function has started this way you cannot turn it off by using the front panel keys.

:AVER:COUN

Syntax [:SENSe]:AVERage:COUNT <numeric>
 [:SENSe]:AVERage:COUNT?

Description Sets the averaging count of the measured value for the averaging function.
 Unlike setting the averaging count with the front panel keys, using this command to set the averaging count does not automatically turn on the averaging function. Therefore, if the averaging function has been set to off, you have to turn it on by using the **:AVER** command.

Parameters

	<numeric>
Description	Averaging count
Range	1 to 256
Initial value	1
Resolution	1

If the specified parameter is out of the allowable setup range, the minimum value (if the lower limit of the range is not reached) or the maximum value (if the upper limit of the range is exceeded) is set.

MAX or MIN can be used to specify the parameters.

Query response {numeric}<newline><^END>

Related commands :AVER on page 131

Equivalent key sequence **[Average]([Blue] - [Meas Time])**

:CAL:CABL

Syntax :CALibration:CABLe <numeric>
 :CALibration:CABLe?

Description Sets the measurement cable length.

Parameters

	<numeric>
Description	Desired cable length
Range	0 to 2
Initial value	0
Unit	m (meter)
Resolution	1

If the specified parameter is out of the allowable setup range, the minimum value (if the lower limit of the range is not reached) or the maximum value (if the upper limit of the range is exceeded) is set.

MAX or MIN can be used to specify the parameters.

Query response {numeric}<newline><^END>

Equivalent key sequence **[Cable]([Blue] - [2])**

:CALC:COMP

Syntax :CALCulate:COMParator[:STATe] {ON|OFF|1|0}
:CALCulate:COMParator[:STATe]?

Description Turns ON/OFF the comparator function.
This setup is interlocked with the ON/OFF state of the signal output of the handler interface.

NOTE Changing the measurement parameter will automatically turn off this function. To avoid this, you have to write a program so that this command is executed after the execution of the measurement parameter setup command (**:CALC1:FORM** and **:CALC2:FORM**).

Parameters

	Description
ON or 1	Turns ON the comparator function.
OFF or 0 (initial value)	Turns OFF the comparator function.

Query response {1|0}<newline><^END>

Related commands :CALC1:FORM on page 147
:CALC2:FORM on page 150

Equivalent key sequence **[Comptr]([Blue] - [1]) - On/Off**

:CALC:COMP:AUXB

Syntax :CALCulate:COMParator:AUXBin {ON|OFF|1|0}
 :CALCulate:COMParator:AUXBin?

Description Turns ON/OFF the AUX_BIN function for sorting of the comparator function.
 Depending on the ON/OFF state of the AUX_BIN function, the following difference occurs in the sorting result when the measurement result of the secondary parameter exceeds the limit range.

ON: Sorted into AUX_BIN if the measurement result of the primary parameter is within the limit range. Otherwise, sorted into OUT_OF_BINS.

OFF: Always sorted into OUT_OF_BINS.

Parameters

	Description
ON or 1	Turns ON the AUX_BIN function.
OFF or 0 (initial value)	Turns OFF the AUX_BIN function.

Query response {1|0}<newline><^END>

Equivalent key sequence **[Comprtr]([Blue] - [1]) - Aux**

:CALC:COMP:BEEP

Syntax :CALCulate:COMParator:BEEPer[:STATe] {ON|OFF|1|0}
 :CALCulate:COMParator:BEEPer[:STATe]?

Description Turns ON/OFF the beep output.
 If you turn off the beep output, the beep sound is not produced, regardless of the sorting result of the comparator.

This command has the same function as the **:SYST:BEEP:STAT** command.

Parameters

	Description
ON or 1 (initial value)	Turns ON the beep output.
OFF or 0	Turns OFF the beep output.

Query response {1|0}<newline><^END>

Related commands :SYST:BEEP:STAT on page 191

Equivalent key sequence **[Config]([Blue] - [-]) - Beep**

:CALC:COMP:BEEP:COND

Syntax :CALCulate:COMParator:BEEPer:CONDition {FAIL|PASS}
:CALCulate:COMParator:BEEPer:CONDition?

Description Sets the condition for producing a beep sound: when sorting with the comparator fails (sorts into any BIN other than BIN1 to BIN9) or passes (sorts into BIN1 to BIN9).

Parameters

	Description
FAIL (initial value)	Instructs the instrument to beep when the sorting fails.
PASS	Instructs the instrument to beep when the sorting pass.

Query response {FAIL|PASS}<newline><^END>

Related commands :CALC:COMP:BEEP on page 135

Equivalent key sequence **[Config]([Blue] - [-]) - Beep**

:CALC:COMP:CLE

Syntax :CALCulate:COMParator:CLEar

Description Clears the ON/OFF state and range of every limit range (BIN1 to BIN9, the limit range for the secondary parameter), the limit range designation method, and the reference value for tolerance mode.

Equivalent key sequence **[Comprtr]([Blue] - [1]) - Limit - Clr - Yes**

:CALC:COMP:COUN

Syntax :CALCulate:COMPArator:COUNt[:STATe] {ON|OFF|1|0}
 :CALCulate:COMPArator:COUNt[:STATe]?

Description Turns ON/OFF the BIN counter function of the comparator function.
 If you turn on this function, the number of DUTs sorted into each BIN based on the comparator sorting result is counted. The maximum count is 999999. If this is exceeded, the count value will not be updated but remain at 999999.

Parameters

	Description
ON or 1	Turns ON the BIN counter function.
OFF or 0 (initial value)	Turns OFF the BIN counter function.

Query response {1|0}<newline><^END>

Related commands :CALC:COMP:COUN:CLE on page 137
 :CALC:COMP:COUN:DATA? on page 138
 :CALC:COMP:COUN:OVLD? on page 140
 :CALC:COMP:COUN:MULT:DATA? on page 139
 :CALC:COMP:COUN:MULT:OVLD? on page 140

Equivalent key sequence **[Comprtr]([Blue] - [1]) - Count**

:CALC:COMP:COUN:CLE

Syntax :CALCulate:COMPArator:COUNt:CLEAr

Description Clears the count value of each BIN (resets it to 0) for the BIN counter function of the comparator function.

Equivalent key sequence **[Comprtr]([Blue] - [1]) - Count - CountClear - Yes**

:CALC:COMP:COUN:DATA?

Syntax :CALCulate:COMParator:COUNt:DATA?

Description Reads out each count value of BIN1 to BIN9, OUT_OF_BINS, and AUX_BIN of the BIN counter function.

Reads out all BIN count values regardless of the ON/OFF state of each BIN (set with the **:CALC:COMP:PRIM:BIN{1-9}:STAT** command). (Query only)

Query response {numeric 1},...,{numeric 11}<newline><^END>

	Description
{numeric 1}	The count value of BIN1.
{numeric 2}	The count value of BIN2.
{numeric 3}	The count value of BIN3.
{numeric 4}	The count value of BIN4.
{numeric 5}	The count value of BIN5.
{numeric 6}	The count value of BIN6.
{numeric 7}	The count value of BIN7.
{numeric 8}	The count value of BIN8.
{numeric 9}	The count value of BIN9.
{numeric 10}	The count value of OUT_OF_BINS.
{numeric 11}	The count value of AUX_BIN.

Related commands :CALC:COMP:COUN:OVLD? on page 140
:CALC:COMP:COUN on page 137
:CALC:COMP:COUN:CLE on page 137
:CALC:COMP:COUN:MULT:DATA? on page 139
:CALC:COMP on page 134
:CALC:COMP:PRIM:BIN{1-9}:STAT on page 143

Equivalent key sequence No equivalent key is available on the front panel.

:CALC:COMP:COUN:MULT:DATA?

Syntax :CALCulate:COMPArator:COUNt:MULTi:DATA?

Description Reads out each count value of BIN1 to BIN9, OUT_OF_BINS, and AUX_BIN of the selected channel.

When the multi-compensation function is tuned off, reads out normal count values (common value for all channels). In other words, this command has the same function as the **:CALC:COMP:COUN:DATA?** command.

Reads out all BIN count values regardless of the ON/OFF state of each BIN (set with the **:CALC:COMP:PRIM:BIN{1-9}:STAT** command). (Query only)

Query response {numeric 1},...,{numeric 11}<newline><^END>

	Description
{numeric 1}	The count value of BIN1 of selected channel.
{numeric 2}	The count value of BIN2 of selected channel.
{numeric 3}	The count value of BIN3 of selected channel.
{numeric 4}	The count value of BIN4 of selected channel.
{numeric 5}	The count value of BIN5 of selected channel.
{numeric 6}	The count value of BIN6 of selected channel.
{numeric 7}	The count value of BIN7 of selected channel.
{numeric 8}	The count value of BIN8 of selected channel.
{numeric 9}	The count value of BIN9 of selected channel.
{numeric 10}	The count value of OUT_OF_BINS of selected channel.
{numeric 11}	The count value of AUX_BIN of selected channel.

Related commands :CALC:COMP:COUN:MULT:OVLD? on page 140

:CORR:MULT on page 161

:CALC:COMP:COUN on page 137

:CALC:COMP:COUN:CLE on page 137

:CALC:COMP:COUN:DATA? on page 138

:CALC:COMP on page 134

:CALC:COMP:PRIM:BIN{1-9}:STAT on page 143

Equivalent key sequence No equivalent key is available on the front panel.

:CALC:COMP:COUN:MULT:OVLD?

Syntax	:CALCulate:COMParator:COUNT:MULTi:OVLD?
Description	Reads out the overload count value of the selected channel. When the multi-compensation function is tuned off, reads out normal count value (common value for all channels). In other words, this command has the same function as the :CALC:COMP:COUN:OVLD? command. (Query only)
Query response	{numeric}<newline><^END>
Related commands	:CALC:COMP:COUN:MULT:DATA? on page 139 :CORR:MULT on page 161 :CALC:COMP:COUN on page 137 :CALC:COMP:COUN:CLE on page 137 :CALC:COMP on page 134
Equivalent key sequence	No equivalent key is available on the front panel.

:CALC:COMP:COUN:OVLD?

Syntax	:CALCulate:COMParator:COUNT:OVLD?
Description	Reads out each overload count value. (Query only)
Query response	{numeric}<newline><^END>
Related commands	:CALC:COMP:COUN:DATA? on page 138 :CALC:COMP:COUN on page 137 :CALC:COMP:COUN:CLE on page 137 :CALC:COMP on page 134
Equivalent key sequence	No equivalent key is available on the front panel.

:CALC:COMP:MODE

Syntax :CALCulate:COMParator:MODE {ABS|DEV|PCNT}
 :CALCulate:COMParator:MODE?

Description Determines how to specify the limit range of the primary parameter for the comparator function.

Parameters

	Description
ABS (initial value)	Specifies the limit border value in an absolute value (absolute mode).
DEV	Specifies the border value relative to the reference value ^{*1} as an absolute value (absolute tolerance mode).
PCNT	Specifies the border value relative to the reference value as a percentage of the reference value ^{*1} (percent tolerance mode).

*1. Use the **:CALC:COMP:PRIM:NOM** command to set the reference value.

Query response {ABS|DEV|PCNT}<newline><^END>

Related commands :CALC:COMP:PRIM:NOM on page 144
 :CALC:COMP:PRIM:BIN{1-9} on page 142

Equivalent key sequence **[Comprtr]([Blue] - [1]) - Limit - Δ Mode**

:CALC:COMP:PRIM:BIN{1-9}

Syntax :CALCulate:COMParator:PRIMary:BIN{1|2|3|4|5|6|7|8|9} <numeric 1>,<numeric 2>
:CALCulate:COMParator:PRIMary:BIN{1|2|3|4|5|6|7|8|9}?

Description Sets the limit ranges of BIN1 to BIN9 as the primary parameter used in the comparator function, depending on the designation method set using the **:CALC:COMP:MODE** command.

This command only sets the limit range. To activate it, use the **:CALC:COMP:PRIM:BIN{1-9}:STAT** command to turn on the BIN for which the limit range has been set.

Parameters

	<numeric 1>	<numeric 2>
Description	The lower limit value of the limit range.	The upper limit value of the limit range.
Range	-999.999 to 999.999	-999.999 to 999.999
Initial value	0	0
Unit	F (farad) or % (percent)	F (farad) or % (percent)

If the specified parameter is out of the allowable setup range, the minimum value (if the lower limit of the range is not reached) or the maximum value (if the upper limit of the range is exceeded) is set. Note that the unit of the parameter may change depending on the limit range designation method.

MAX or MIN can be used to specify the parameters.

Query response {numeric 1},{numeric 2}<newline><^END>

Related commands :CALC:COMP:MODE on page 141
:CALC:COMP:PRIM:BIN{1-9}:STAT on page 143
:CALC:COMP:SEC:LIM on page 145
:CALC:COMP on page 134

Equivalent key sequence **[Pri Low]** and **[Pri High]** (Only BIN1 can be set.)
[Comprtr]([Blue] - [1]) - Limit - Pri (All BINs can be set.)

:CALC:COMP:PRIM:BIN{1-9}:STAT

Syntax :CALCulate:COMParator:PRIMary:BIN{1|2|3|4|5|6|7|8|9}:STATe {ON|OFF|1|0}
 :CALCulate:COMParator:PRIMary:BIN{1|2|3|4|5|6|7|8|9}:STATe?

Description Turns ON/OFF BIN1 to BIN9 of the comparator function.
 Only BINs that you turn on using this command are used for the sorting judgment of the comparator function.

Parameters

	Description
ON or 1 (initial value of BIN1)	Turns ON BIN.
OFF or 0 (initial value of BIN2 to BIN9)	Turns OFF BIN.

Query response {1|0}<newline><^END>

Related commands :CALC:COMP:PRIM:BIN{1-9} on page 142
 :CALC:COMP:SEC:STAT on page 146
 :CALC:COMP on page 134

Equivalent key sequence **[Comprtr]([Blue] - [1]) - Limit - Pri**

:CALC:COMP:PRIM:NOM

Syntax :CALCulate:COMParator:PRIMary:NOMinal <numeric>
:CALCulate:COMParator:PRIMary:NOMinal?

Description Specifies the reference value used when specifying the primary parameter limit range for the comparator function. This value can be used when the limit range designation method is set to either absolute tolerance mode or percent tolerance mode.

Parameters

	<numeric>
Description	The reference value used when specifying the primary parameter limit range.
Range	-999.999 to 999.999
Initial value	0
Unit	F (farad)

If the specified parameter is out of the allowable setup range, the minimum value (if the lower limit of the range is not reached) or the maximum value (if the upper limit of the range is exceeded) is set.

MAX or MIN can be used to specify the parameters.

Query response {numeric}<newline><^END>

Related commands :CALC:COMP:MODE on page 141
:CALC:COMP:PRIM:BIN{1-9} on page 142

Equivalent key sequence **[Comptr]([Blue] - [1]) - Limit - Δ ABS / Δ %**

:CALC:COMP:SEC:LIM

Syntax :CALCulate:COMParator:SECOndary:LIMit <numeric 1>,<numeric 2>
 :CALCulate:COMParator:SECOndary:LIMit?

Description Sets the limit range for the secondary parameter used in the comparator function.
 This command only sets the limit range. To activate the set limit range, use the **:CALC:COMP:SEC:STAT** command to enable sorting judgment for the measurement result of the secondary parameter.

Parameters

	<numeric 1>	<numeric 2>
Description	The lower limit value of the limit range.	The upper limit value of the limit range.
Range	-99.9999E9 to 99.9999E9	-99.9999E9 to 99.9999E9
Initial value	0	0
Unit	Depends on the type of parameter.	Depends on the type of parameter.

If the specified parameter is out of the allowable setup range, the minimum value (if the lower limit of the range is not reached) or the maximum value (if the upper limit of the range is exceeded) is set.

MAX or MIN can be used to specify the parameters.

Query response {numeric 1},{numeric 2}<newline><^END>

Related commands :CALC:COMP:SEC:STAT on page 146
 :CALC:COMP:PRIM:BIN{1-9} on page 142
 :CALC:COMP on page 134

Equivalent key sequence **[Sec Low]([Blue] - [Pri Low])** and **[Sec High]([Blue] - [Pri High])**
[Comptr]([Blue] - [1]) - Limit - Sec

:CALC:COMP:SEC:STAT

Syntax :CALCulate:COMParator:SECOndary:STATe {ON|OFF|1|0}
:CALCulate:COMParator:SECOndary:STATe?

Description Sets whether to enable sorting judgment for the measurement result of the secondary parameter when using the comparator function.

Parameters

	Description
ON or 1 (initial value)	Enables sorting judgment for the measurement result of the secondary parameter.
OFF or 0	Disables sorting judgment for the measurement result of the secondary parameter.

Query response {1|0}<newline><^END>

Related commands :CALC:COMP:SEC:LIM on page 145
:CALC:COMP:PRIM:BIN{1-9}:STAT on page 143
:CALC:COMP on page 134

Equivalent key sequence **[Comprtr]([Blue] - [1]) - Limit - Sec**

:CALC1:FORM

Syntax :CALCulate1:FORMat {CP|CS}
 :CALCulate1:FORMat?

Description Specifies the primary parameter to be measured.
 When the secondary parameter has been set to G or RP and the primary parameter is set to CS, the secondary parameter is automatically changed to D. Also, when the secondary parameter has been set to RS and the primary parameter is set to CP, the secondary parameter is automatically changed to D.

Parameters

	Description
CP (initial value)	Specifies the capacitance value measured using the parallel equivalent circuit model for the primary parameter.
CS	Specifies the capacitance value measured using the series equivalent circuit model for the primary parameter.

Query response {CP|CS}<newline><^END>

Related commands :CALC2:FORM on page 150

Equivalent key sequence **[Meas Prmtr]**

:CALC1:MATH:EXPR:CAT?

Syntax :CALCulate1:MATH:EXPRession:CATalog?

Description Reads out available parameters used when executing the command to specify the expression of the primary parameter in the deviation measurement mode (the **:CALC1:MATH:EXPR:NAME** command). The query response is always DEV,PCNT. (Query only)

Query response DEV,PCNT<newline><^END> (fixed)

Related commands :CALC1:MATH:EXPR:NAME on page 148

Equivalent key sequence No equivalent key is available on the front panel.

:CALC1:MATH:EXPR:NAME

Syntax :CALCulate1:MATH:EXPRession:NAME {DEV|PCNT}
:CALCulate1:MATH:EXPRession:NAME?

Description Specifies the expression of the primary parameter used when displaying the measurement result in the deviation measurement mode.

Parameters

	Description
DEV (initial value)	Displays the result in the difference between the measurement value and the reference value ^{*1} (measurement value - reference value).
PCNT	Displays the difference between the measurement value and the reference value ^{*1} in a percentage ^{*2} to the reference value.

*1. Use the **:DATA {REF1|REF2}** command to set the reference value.

*2. $(\text{Measurement value} - \text{reference value}) / \text{reference value} \times 100$

Query response {DEV|PCNT}<newline><^END>

Related commands :CALC1:MATH:STAT on page 149
:CALC2:MATH:EXPR:NAME on page 151
:DATA {REF1|REF2} on page 172

Equivalent key sequence **[Δ Mode]([Blue] - [Meas Prmtr]) - Pri**

:CALC1:MATH:STAT

Syntax :CALCulate1:MATH:STATe {ON|OFF|1|0}
 :CALCulate1:MATH:STATe?

Description Determines whether to use the function (deviation measurement mode) that displays the primary parameter measurement result in deviation from the reference value (set using the **:DATA** command).

NOTE Changing any of the measurement parameters will automatically disable this function. To avoid this, you have to write a program so that this command is executed after the execution of the measurement parameter setup command (**:CALC1:FORM** and **:CALC2:FORM**).

Parameters

	Description
ON or 1	Enables the deviation measurement mode.
OFF or 0 (initial value)	Disables the deviation measurement mode (in other words, displays the measurement result in an absolute value).

Query response {1|0}<newline><^END>

Related commands :CALC1:MATH:EXPR:NAME on page 148
 :CALC1:FORM on page 147
 :CALC2:FORM on page 150
 :CALC2:MATH:STAT on page 152

Equivalent key sequence **[Δ Mode]([Blue] - [Meas Prmtr]) - Pri**

:CALC2:FORM

Syntax :CALCulate2:FORMat {D|Q|G|RP|RS}
:CALCulate2:FORMat?

Description Specifies the secondary parameter to be measured.

If the primary parameter has been set to CP and the secondary parameter is set to RS, the primary parameter is automatically changed to CS. Also, if the primary parameter has been set to CS and the secondary parameter is set to G or RP, the primary parameter is automatically set to CP.

Parameters

	Description
D (initial value)	Specifies the dissipation factor as the secondary parameter.
Q	Specifies the quality factor (inverse value of D) as the secondary parameter.
G	Specifies the equivalent parallel conductance measured using the parallel equivalent circuit model as the secondary parameter.
RP	Specifies the equivalent parallel resistance measured using the parallel equivalent circuit model as the secondary parameter.
RS	Specifies the equivalent series resistance measured using the series equivalent circuit model as the secondary parameter.

Query response {D|Q|G|RP|RS}<newline><^END>

Related commands :CALC1:FORM on page 147

Equivalent key sequence **[Meas Prmtr]**

:CALC2:MATH:EXPR:CAT?

Syntax :CALCulate2:MATH:EXPRession:CATalog?

Description Reads out available parameters used when executing the command to specify the expression of the secondary parameter in the deviation measurement mode (the **:CALC1:MATH:EXPR:NAME** command). The query response is always DEV,PCNT. (Query only)

Query response DEV,PCNT<newline><^END> (fixed)

Related commands :CALC2:MATH:EXPR:NAME on page 151

Equivalent key sequence No equivalent key is available on the front panel.

:CALC2:MATH:EXPR:NAME

Syntax :CALCulate2:MATH:EXPRession:NAME {DEV|PCNT}
 :CALCulate2:MATH:EXPRession:NAME?

Description Specifies the expression of the secondary parameter used when displaying the measurement result in the deviation measurement mode.

Parameters

	Description
DEV (initial value)	Displays the result as the difference between the measurement value and the reference value ^{*1} (measurement value - reference value).
PCNT	Displays the difference between the measurement value and the reference value ^{*1} as a percentage ^{*2} of the reference value.

*1. Use the **:DATA {REF1|REF2}** command to set the reference value.

*2. (Measurement value - reference value) / reference value × 100

Query response {DEV|PCNT}<newline><^END>

Related commands :CALC2:MATH:STAT on page 152
 :CALC1:MATH:EXPR:NAME on page 148
 :DATA {REF1|REF2} on page 172

Equivalent key sequence [**Δ Mode**]([**Blue**] - [**Meas Prmtr**]) - **Sec**

:CALC2:MATH:STAT

Syntax :CALCulate2:MATH:STATe {ON|OFF|1|0}
:CALCulate2:MATH:STATe?

Description Determines whether to use the function (deviation measurement mode) that displays the secondary parameter measurement result as deviation from the reference value (set using the **:DATA** command).

NOTE Changing any of the measurement parameters will automatically disable this function. To avoid this, you have to write a program so that this command is executed after the execution of the measurement parameter setup command (**:CALC1:FORM** and **:CALC2:FORM**).

Parameters

	Description
ON or 1	Enables the deviation measurement mode.
OFF or 0 (initial value)	Disables the deviation measurement mode (i.e., displays the measurement result as an absolute value).

Query response {1|0}<newline><^END>

Related commands :CALC2:MATH:EXPR:NAME on page 151
:CALC1:FORM on page 147
:CALC2:FORM on page 150
:CALC1:MATH:STAT on page 149

Equivalent key sequence [**Δ Mode**]([**Blue**] - [**Meas Prmtr**]) - **Sec**

:CALC3:MATH:STAT

Syntax :CALCulate3:MATH:STATe {ON|OFF|1|0}
 :CALCulate3:MATH:STATe?

Description Determines whether to use the monitor function of the current flowing through the DUT during measurement.

Parameters

	Description
ON or 1	Enables the current monitor function.
OFF or 0 (initial value)	Disables the current monitor function.

Query response {1|0}<newline><^END>

Related commands :CALC4:MATH:STAT on page 153

Equivalent key sequence **[Level Mon]**(**[Blue]** - **[Show Setting]**)

:CALC4:MATH:STAT

Syntax :CALCulate4:MATH:STATe {ON|OFF|1|0}
 :CALCulate4:MATH:STATe?

Description Determines whether to use the monitor function of the voltage applied to the DUT during measurement.

Parameters

	Description
ON or 1	Enables the voltage monitor function.
OFF or 0 (initial value)	Disables the voltage monitor function.

Query response {1|0}<newline><^END>

Related commands :CALC3:MATH:STAT on page 153

Equivalent key sequence **[Level Mon]**(**[Blue]** - **[Show Setting]**)

:CORR:CKIT:STAN1:FORM

Syntax `[:SENSe]:CORRection:CKIT:STANdard1:FORMat {GB|CPG}`
`[:SENSe]:CORRection:CKIT:STANdard1:FORMat?`

Description Sets the parameter types of the OPEN compensation data.

Parameters

	Description
GB (initial value)	Specifies G as the primary parameter and B as the secondary parameter.
CPG	Specifies CP as the primary parameter and G as the secondary parameter.

Query response `{GB|CPG}<newline><^END>`

Related commands `:CORR:DATA` on page 158

Equivalent key sequence **[Open]([Blue] - [4]) - CorVal - PrmSlct**

:CORR:CKIT:STAN2:FORM

Syntax `[:SENSe]:CORRection:CKIT:STANdard2:FORMat {RX|LSRS}`
`[:SENSe]:CORRection:CKIT:STANdard2:FORMat?`

Description Sets the parameter types of the SHORT compensation data.

Parameters

	Description
RX (initial value)	Specifies R as the primary parameter and X as the secondary parameter.
LSRS	Specifies Ls as the primary parameter and Rs as the secondary parameter.

Query response `{GB|CPG}<newline><^END>`

Related commands `:CORR:DATA` on page 158

Equivalent key sequence **[Short]([Blue] - [5]) - CorVal - PrmSlct**

:CORR:CKIT:STAN3

Syntax [:SENSe]:CORRection:CKIT:STANdard3 <numeric 1>,<numeric 2>
[:SENSe]:CORRection:CKIT:STANdard3?

Description Defines the values of the LOAD compensation standard for the parameters you specify by using the **:CORR:CKIT:STAN3:FORM** command.

These are set as the standard values for the measurement frequency when executing the command (set with the **:SOUR:FREQ** command).

When using the multi-compensation function (set to ON with the **:CORR:MULT** command) with the channel-by-channel definition of the standard values enabled (set to ON with the **:CORR:MULT:CKIT:STAN3** command), the standard values for the selected channel (selected with the **:CORR:MULT:CHAN** command) are set at execution of the command.

Parameters

	<numeric 1>	<numeric 2>
Description	Value of the primary parameter.	Value of the secondary parameter.
Range	-999.999 to 999.999	-99.9999E9 to 99.9999E9
Initial value	100E-9	0
Unit	F (farad)	Depends on the type of parameter.

If the specified parameter is out of the allowable setup range, the minimum value (if the lower limit of the range is not reached) or the maximum value (if the upper limit of the range is exceeded) is set.

MAX or MIN can be used to specify the parameters.

Query response {numeric 1},{numeric 2}<newline><^END>

Related commands :CORR:LOAD on page 160
:CORR:CKIT:STAN3:FORM on page 156
:CORR:MULT on page 161
:CORR:MULT:CHAN on page 161
:CORR:MULT:CKIT:STAN3 on page 162

Equivalent key sequence [Load]([Blue] - [6]) - CorVal - RefEnt

:CORR:CKIT:STAN3:FORM

Syntax [:SENSe]:CORRection:CKIT:STANdard3:FORMat {CPD|CPQ|CPG|CPRP|CSD|CSQ|CSRS}
[:SENSe]:CORRection:CKIT:STANdard3:FORMat?

Description Sets the types of parameters used to define the standard for LOAD compensation.

Parameters

	Description
CPD (initial value)	Specifies CP as the primary parameter, D as the secondary parameter.
CPQ	Specifies CP as the primary parameter, Q as the secondary parameter.
CPG	Specifies CP as the primary parameter, G as the secondary parameter.
CPRP	Specifies CP as the primary parameter, RP as the secondary parameter.
CSD	Specifies CS as the primary parameter, D as the secondary parameter.
CSQ	Specifies CS as the primary parameter, Q as the secondary parameter.
CSRS	Specifies CS as the primary parameter, RS as the secondary parameter.

For details on CP and CS, refer to :CALC1:FORM on page 147. For details on D, Q, RP, and RS, refer to :CALC2:FORM on page 150.

Query response {CPD|CPQ|CPG|CPRP|CSD|CSQ|CSRS}<newline><^END>

Related commands :CORR:CKIT:STAN3 on page 155

Equivalent key sequence **[Load]([Blue] - [6]) - CorVal - PrmSlct**

:CORR:COLL

- Syntax** [:SENSe]:CORRection:COLLect[:ACQuire] {STANdard1|STANdard2|STANdard3}
- Description** Measures the compensation data for OPEN/SHORT/LOAD compensation and turns on the compensation function.
- These compensation data are measured for the measurement frequency used in executing the command (set with the **:SOUR:FREQ** command).
- When using the multi-compensation function (set to ON with the **:CORR:MULT** command), this is measured as the compensation data for the selected channel when executing the command (selected with the **:CORR:MULT:CHAN** command). (No query)

Parameters

	Description
STANdard1	Specifies the OPEN compensation.
STANdard2	Specifies the SHORT compensation.
STANdard3	Specifies the LOAD compensation.

- Related commands** :CORR:OPEN on page 165
 :CORR:SHOR on page 165
 :CORR:LOAD on page 160
 :CORR:MULT on page 161
 :CORR:MULT:CHAN on page 161

- Equivalent key sequence** **[Open]([Blue] - [4]) - OpenMeas**
[Short]([Blue] - [5]) - ShortMeas
[Load]([Blue] - [6]) - LoadMeas

:CORR:DATA

Syntax [:SENSe]:CORRection:DATA {STANdard1|STANdard2|STANdard3},<numeric 1>,<numeric 2>
[:SENSe]:CORRection:DATA? {STANdard1|STANdard2|STANdard3}

Description Sets the compensation data for OPEN/SHORT/LOAD compensation.

These compensation data are measured for the measurement frequency used in executing the command (set with the **:SOUR:FREQ** command).

When using the multi-compensation function (set to ON with the **:CORR:MULT** command), this is set as the compensation data for the selected channel when executing the command (selected with the **:CORR:MULT:CHAN** command).

To activate the set compensation data, use the **:CORR:OPEN**, **:CORR:SHOR**, and **:CORR:LOAD** commands to turn on the OPEN/SHORT/LOAD compensation function.

The transfer format of data read out with this command conforms to the setup of the **:FORM** command.

Parameters

	Parameter 1: {STANdard1 STANdard2 STANdard3}
STANdard1	Sets or reads out the data for OPEN compensation.
STANdard2	Sets or reads out the data for SHORT compensation.
STANdard3	Sets or reads out the data for LOAD compensation.

- When specifying STANdard1 as parameter 1:

	Parameter 2: <numeric 1>	Parameter 3: <numeric 2>
Description	Value of the primary parameter *1.	Value of the secondary parameter *1.
Range	-99.9999E9 to 99.9999E9	-99.9999E9 to 99.9999E9
Initial value	0	0
Unit	Depends on the type of parameter.	Depends on the type of parameter.

*1. Use the **:CORR:CKIT:STAN1:FORM** command to specify the type of parameter.

- When specifying STANdard2 as parameter 1:

	Parameter 2: <numeric 1>	Parameter 3: <numeric 2>
Description	Value of the primary parameter *1.	Value of the secondary parameter *1.
Range	-99.9999E9 to 99.9999E9	-99.9999E9 to 99.9999E9
Initial value	0	0
Unit	Depends on the type of parameter.	Depends on the type of parameter.

*1. Use the **:CORR:CKIT:STAN2:FORM** command to specify the type of parameter.

- When specifying STANdard3 as parameter 1:

	Parameter 2: <numeric 1>	Parameter 3: <numeric 2>
Description	Value of the primary parameter *1.	Value of the secondary parameter *1.
Range	-999.999 to 999.999	-99.9999E9 to 99.9999E9
Initial value	100E-9	0
Unit	F (farad)	Depends on the type of parameter.

*1. Use the :CORR:CKIT:STAN3:FORM command to specify the type of parameter.

In any case, if the specified parameter is out of the allowable setup range, the minimum value (if the lower limit of the range is not reached) or the maximum value (if the upper limit of the range is exceeded) is set.

MAX or MIN can be used to specify parameter 2 and parameter 3.

Query response {numeric 1},{numeric 2}<newline><^END>

Related commands :CORR:OPEN on page 165
:CORR:SHOR on page 165
:CORR:LOAD on page 160
:CORR:MULT on page 161
:CORR:MULT:CHAN on page 161
:CORR:CKIT:STAN1:FORM on page 154
:CORR:CKIT:STAN2:FORM on page 154
:CORR:CKIT:STAN3:FORM on page 156
:FORM on page 182

Equivalent key sequence
[Open]([Blue] - [4]) - MeasVal
[Short]([Blue] - [5]) - MeasVal
[Load]([Blue] - [6]) - CorVal - MeasVal

You can only check the setup values. You cannot set them.

:CORR:LOAD

Syntax `[:SENSe]:CORRection:LOAD[:STATe] {ON|OFF|1|0}`
`[:SENSe]:CORRection:LOAD[:STATe]?`

Description Turns ON/OFF the LOAD compensation function.

With the LOAD compensation set to ON, if you change the cable length (set with the **:CAL:CABL** command) or frequency shift (set with the **:SYST:FSH** command), the LOAD compensation is automatically changed to OFF.

Parameters

	Description
ON or 1	Turns ON the LOAD compensation.
OFF or 0 (initial value)	Turns OFF the LOAD compensation.

Query response `{1|0}<newline><^END>`

Related commands `:CAL:CABL` on page 133
`:SYST:FSH` on page 192
`:CORR:COLL` on page 157

Equivalent key sequence **[Load]([Blue] - [6]) - On/Off**

:CORR:MULT

Syntax
[:SENSe]:CORRection:MULTiple[:STATe] {ON|OFF|1|0}
[:SENSe]:CORRection:MULTiple[:STATe]?

Description
Turns ON/OFF the multi-compensation function.
This setup is interlocked with the ON/OFF state of the signal output of the scanner interface.

Parameters

	Description
ON or 1	Turns ON the multi-compensation function.
OFF or 0 (initial value)	Turns OFF the multi-compensation function.

Query response
{1|0}<newline><^END>

Equivalent key sequence
[Scanner]([Blue] - [9]) - On/Off

:CORR:MULT:CHAN

Syntax
[:SENSe]:CORRection:MULTiple:CHANnel <numeric>
[:SENSe]:CORRection:MULTiple:CHANnel?

Description
Specifies a channel number used in the multi-compensation function.
You can also specify the channel number via the scanner interface. Note that a channel number specified through the interface overrides a channel number selected with this command.

Parameters

	<numeric>
Description	The desired channel number.
Range	0 to 63
Initial value	0
Resolution	1

If the specified parameter is out of the allowable setup range, an error occurs.
MAX or MIN can be used to specify the parameters.

Query response
{numeric}<newline><^END>

Equivalent key sequence
[Scanner]([Blue] - [9]) - Channel

:CORR:MULT:CKIT:STAN3

Syntax `[[:SENSe]:CORRection:MULTiple:CKIT:STANdard3[:STATe] {ON|OFF}|1|0]`
`[[:SENSe]:CORRection:MULTiple:CKIT:STANdard3[:STATe]?`

Description Determines whether to define the standard values for LOAD compensation for each channel individually when using the multi-compensation function (set to ON with the **:CORR:MULT** command).

Parameters

	Description
ON or 1	Enables channel-by-channel value definition.
OFF or 0 (initial value)	Disables channel-by-channel value definition (defines the same values for all channels).

Query response `{1|0}<newline><^END>`

Related commands `:CORR:MULT` on page 161
`:CORR:CKIT:STAN3` on page 155

Equivalent key sequence **[Scanner]([Blue] - [9]) - LoadRef**

:CORR:OFFS

Syntax `[[:SENSe]:CORRection:OFFSet[:STATe] {ON|OFF|1|0}`
`[[:SENSe]:CORRection:OFFSet[:STATe]?`

Description Turns ON/OFF the offset compensation function.

NOTE Changing this parameter will automatically turn off this function. To avoid this, you have to write a program so that this command is executed after the execution of the measurement parameter setup command (**:CALC1:FORM** and **:CALC2:FORM**).

Parameters

	Description
ON or 1	Turns ON the offset compensation function.
OFF or 0 (initial value)	Turns OFF the offset compensation function.

Query response `{1|0}<newline><^END>`

Related commands `:CORR:OFFS:DATA` on page 164
`:CALC1:FORM` on page 147
`:CALC2:FORM` on page 150

Equivalent key sequence **[Offset]([Blue] - [3]) - On/Off**

:CORR:OFFS:DATA

Syntax [:SENSe]:CORRection:OFFSet:DATA <numeric 1>,<numeric 2>
[:SENSe]:CORRection:OFFSet:DATA?

Description Sets the compensation values for the primary parameter and secondary parameter used in the offset compensation function.
These compensation data are measured for the measurement frequency used in executing the command (set with the **:SOUR:FREQ** command).

Parameters

	<numeric 1>	<numeric 2>
Description	The offset compensation value for the primary parameter.	The offset compensation value for the secondary parameter.
Range	-999.999 to 999.999	-99.9999E9 to 99.9999E9
Initial value	0	0
Unit	F (farad)	Depends on the setup of the secondary parameter.

If the specified parameter is out of the allowable setup range, the minimum value (if the lower limit of the range is not reached) or the maximum value (if the upper limit of the range is exceeded) is set. Note that the unit of the parameter changes depending on the limit range designation method.

MAX or MIN can be used to specify the parameters.

Query response {numeric 1},{numeric 2}<newline><^END>

Related commands :CORR:OFFS on page 163

Equivalent key sequence **[Offset]([Blue] - [3]) - OfEnt**

:CORR:OPEN

Syntax [:SENSe]:CORRection:OPEN[:STATe] {ON|OFF|1|0}
 [:SENSe]:CORRection:OPEN[:STATe]?

Description Turns ON/OFF the OPEN compensation.
 With the OPEN compensation set to ON, if you change the cable length (set with the **:CAL:CABL** command) or frequency shift (set with the **:SYST:FSH** command), the OPEN compensation is automatically changed to OFF.

Parameters

	Description
ON or 1	Turns ON the OPEN compensation.
OFF or 0 (initial value)	Turns OFF the OPEN compensation.

Query response {1|0}<newline><^END>

Related commands :CAL:CABL on page 133
 :SYST:FSH on page 192
 :CORR:COLL on page 157

Equivalent key sequence **[Open]([Blue] - [4]) - On/Off**

:CORR:SHOR

Syntax [:SENSe]:CORRection:SHORT[:STATe] {ON|OFF|1|0}
 [:SENSe]:CORRection:SHORT[:STATe]?

Description Turns ON/OFF the SHORT compensation.
 With the SHORT compensation set to ON, if you change the cable length (set with the **:CAL:CABL** command) or frequency shift (set with the **:SYST:FSH** command), the SHORT compensation is automatically changed to OFF.

Parameters

	Description
ON or 1	Turns ON the SHORT compensation.
OFF or 0 (initial value)	Turns OFF the SHORT compensation.

Query response {1|0}<newline><^END>

Related commands :CAL:CABL on page 133
 :SYST:FSH on page 192
 :CORR:COLL on page 157

Equivalent key sequence **[Short]([Blue] - [5]) - On/Off**

:CREJ**:CREJ**

Syntax `[:SENSe][:FIMPedance]:CREJect[:STATe] {ON|OFF|1|0}`
`[:SENSe][:FIMPedance]:CREJect[:STATe]?`

Description Enables/disables the Low C reject function.

When you enable the Low C reject function, if the measured value of the primary parameter (Cp or Cs) is too small (equal to or less than the boundary value specified with the **:CREJ:LIM** command), Low C is detected. For information on the screen display, GPIB output, and so on when Low C is detected, refer to Appendix E, “At-a-glance Table of Operations When Overload or Low C is Detected.”

Parameters

	Description
ON or 1	Enables the Low C reject function.
OFF or 0 (initial value)	Disables the Low C reject function.

Query response `{1|0}<newline><^END>`

Related commands `:CREJ:LIM` on page 167

Equivalent key sequence **[Low C Rej]** key (Blue key, **[Level]** key)

:CREJ:LIM

Syntax [:SENSe][:FIMPedance]:CREJect:LIMit <numeric>
[:SENSe][:FIMPedance]:CREJect:LIMit

Description Sets the boundary value (percentage of the measurement range) within the detection range of Low C when you turn on the Low C reject function. The measurement range to which the set value is applied differs depending on the setup of the measurement range mode as shown below.

- When in auto-range mode (ON has been specified with the **:RANG:AUTO** command):
 - When the measurement frequency is in the 1 kHz: 100E-12 F (100 pF) range
 - When the measurement frequency is in the 1 MHz: 1E-12 F (1 pF) range
- When in the fixed range mode (OFF has been specified with the **:RANG:AUTO** command):
 - The selected measurement range

For example, if you make a measurement with the range fixed to the 1 μ F range and specify 1%, Low C is detected if the measured value of the primary parameter (Cs or Cp) is 10 nF or less.

For information on the screen display, GPIB output, and so on when Low C is detected, refer to Appendix E, “At-a-glance Table of Operations When Overload or Low C is Detected,”.

Parameters

	<numeric>
Description	Boundary value
Range	0 to 10
Initial value	0
Unit	% (percent)

If the specified parameter is out of the allowable setup range, the minimum value (if the lower limit of the range is not reached) or the maximum value (if the upper limit of the range is exceeded) is set.

MAX or MIN can be used to specify the parameters.

Query response {numeric}<newline><^END>

Related commands :CREJ on page 166
:RANG on page 184
:RANG:AUTO on page 185

Equivalent key sequence **[Low C Rej]([Blue] - [Level]) - Limit**

:DATA

The function of this command when executed varies depending on the 1st parameter specified as shown in the table below.

1st parameter	Function
BUF1, BUF2 or BUF3	Reads out data in data buffer 1, data buffer 2, or data buffer 3. For details, refer to :DATA? {BUF1 BUF2 BUF3} on page 168.
IMON or VMON	Reads out the measured value of the current monitor or voltage monitor. For details, refer to :DATA? {IMON VMON} on page 171.
REF1 or REF2	Sets or reads out the reference value of the primary parameter or secondary parameter used in the deviation measurement mode. For details, refer to :DATA {REF1 REF2} on page 172.

:DATA? {BUF1|BUF2|BUF3}

Syntax :DATA[:DATA]? {BUF1|BUF2|BUF3}

Description Reads out data in data buffer 1, data buffer 2 or data buffer 3. Executing this command rewinds the pointer to the specified data buffer (the location to feed measurement data) to the start. (Query only)

The transfer format of data read out with this command conforms to the setup made with the **:FORM** command.

Parameters

	Description
BUF1	Reads out data in data buffer 1.
BUF2	Reads out data in data buffer 2.
BUF3	Reads out data in data buffer 3.

Query response

When specifying BUF1 or BUF2 as parameter

{numeric 1},{numeric 2},{numeric 3},...,{numeric (N×3)}<newline><^END>

The N sets of measurement data (a data set consists of the measurement status, measured value, and comparator sorting result) fed into the data buffer are read out in the order of measurement.

Where N is the number of measurement points specified with the **:DATA:POIN** command and n is an integer between 1 and N:

{numeric (n-1)×3+1}	<p>The measurement status in the n-th measurement (an integer between 0 and 2 as shown below).</p> <p>0: No error 1: Detection of measurement impossibility (overload) 2: Detection of Low C reject</p>
{numeric (n-1)×3+2}	<p>The measured value of the primary or secondary parameter *1 in the n-th measurement. If overload is detected, 9.9E37 is outputted.</p>
{numeric (n-1)×3+3}	<p>The comparator sorting result in the n-th measurement (an integer between 0 and 11 as shown below). The output (output value is 11) is produced even if the comparator is off.</p> <p>0: Sorted into OUT_OF_BINS. 1: Sorted into BIN1. 2: Sorted into BIN2. 3: Sorted into BIN3. 4: Sorted into BIN4. 5: Sorted into BIN5. 6: Sorted into BIN6. 7: Sorted into BIN7. 8: Sorted into BIN8. 9: Sorted into BIN9. 10: AUX_BIN 11: BIN_NA (sorting impossible)</p>

*1. You need to select primary parameter or secondary parameter by using the **:DATA:FEED** command in advance.

:DATA

When specifying BUF3 as parameter (Comparator: OFF)

{numeric 1},{numeric 2},{numeric 3},...,{numeric (N×3)}<newline><^END>

The N sets of measurement data (a data set consists of the measurement status, measured value, and comparator sorting result) fed into the data buffer are read out in the order of measurement.

Where N is the number of measurement points specified with the **:DATA:POIN** command and n is an integer between 1 and N:

{numeric (n-1)×3+1}	The measurement status in the n-th measurement (an integer between 0 and 2).
{numeric (n-1)×3+2}	The measured value of the primary parameter in the n-th measurement. If overload is detected, 9.9E37 is outputted.
{numeric (n-1)×3+3}	The measured value of the secondary parameter in the n-th measurement. If overload is detected, 9.9E37 is outputted.

When specifying BUF3 as parameter (Comparator: ON)

{numeric 1},{numeric 2},{numeric 3},{numeric 4},...,{numeric (N×4)}<newline><^END>

The N sets of measurement data (a data set consists of the measurement status, measured value, and comparator sorting result) fed into the data buffer are read out in the order of measurement.

Where N is the number of measurement points specified with the **:DATA:POIN** command and n is an integer between 1 and N:

{numeric (n-1)×3+1}	The measurement status in the n-th measurement (an integer between 0 and 2).
{numeric (n-1)×3+2}	The measured value of the primary parameter in the n-th measurement. If overload is detected, 9.9E37 is outputted.
{numeric (n-1)×3+3}	The measured value of the secondary parameter in the n-th measurement. If overload is detected, 9.9E37 is outputted.
{numeric (n-1)×3+4}	The comparator sorting result in the n-th measurement (an integer between 0 and 11). The output (output value is 11) is produced even if the comparator is off.

- Related commands :DATA:FEED on page 173
 :DATA:FEED:CONT on page 174
 :DATA:POIN on page 175
 :FETC? on page 181
 :FORM on page 182

Equivalent key sequence No equivalent key can be used on the front panel.

:DATA? {IMON|VMON}

Syntax :DATA[:DATA]? {IMON|VMON}

Description Reads out the current monitor value or voltage monitor value of the measured signal. If the monitor function is disabled (OFF has been specified with the **:CALC3:MATH:STAT** command or **:CALC4:MATH:STAT** command) or the measurement fails, 9.9E37 is read out. (Query only)

The transfer format of data read out with this command conforms to the setup made with the **:FORM** command.

Parameters

	Description
IMON	Reads out the current monitor.
VMON	Reads out the voltage monitor.

Query response {numeric}<newline><^END>

Related commands :CALC3:MATH:STAT on page 153
:CALC4:MATH:STAT on page 153
:FORM on page 182

Equivalent key sequence No equivalent key is available on the front panel.

:DATA**:DATA {REF1|REF2}**

Syntax :DATA[:DATA] {REF1|REF2},<numeric>
:DATA[:DATA]? {REF1|REF2}

Description Sets the reference value used in the deviation measurement mode for the primary parameter or secondary parameter. This reference value is used when the deviation measurement mode has been enabled for the primary parameter or secondary parameter (ON has been specified with the **:CALC1:MATH:STAT** command or **:CALC2:MATH:STAT** command).

The transfer format of data read out with this command conforms to the setup made with the **:FORM** command.

Parameters

	Description
REF1	Sets or reads out the reference value for the primary parameter used in the deviation measurement mode.
REF2	Sets or reads out the reference value for the secondary parameter used in the deviation measurement mode.

	<numeric>
Description	Reference value used in the deviation measurement mode
Range	-999.99 to 999.99 (for REF1) -99.999E9 to 99.999E9 (for REF2)
Initial value	0
Unit	Depends on the type of parameter.

If the specified parameter is out of the allowable setup range, the minimum value (if the lower limit of the range is not reached) or the maximum value (if the upper limit of the range is exceeded) is set.

MAX or MIN can be used to specify the parameters.

Query response {numeric}<newline><^END>

Related commands :CALC1:MATH:STAT on page 149

:CALC2:MATH:STAT on page 152

:FORM on page 182

Equivalent key sequence No equivalent key is available on the front panel.

:DATA:FEED

Syntax :DATA:FEED {BUF1|BUF2},{"CALCulate1"|"CALCulate2"|""}
:DATA:FEED? {BUF1|BUF2}

Description Selects the measurement data fed into data buffer 1 or data buffer 2 from the following: primary parameter, secondary parameter, or none to be fed. The query response is a string with double quotation marks ("").

Parameters

	Description
BUF1	Specifies data buffer 1, to which the {"CALCulate1" "CALCulate2" ""} setting is applied or reads out the setup of data buffer 1.
BUF2	Specifies data buffer 2, to which the {"CALCulate1" "CALCulate2" ""} setting is applied. Or reads out the setup of data buffer 2.

	Description
"CALCulate1"	Specifies the primary parameter as the measurement data fed into the data buffer specified with {BUF1 BUF2}.
"CALCulate2"	Specifies the secondary parameter as the measurement data fed into the data buffer specified with {BUF1 BUF2}.
"" (initial value)	Does not feed the measurement data into the data buffer specified with {BUF1 BUF2}.

Query response {"CALCulate1"|"CALCulate2"|""}<newline><^END>

Related commands :DATA:FEED:CONT on page 174
:DATA:POIN on page 175

Equivalent key sequence No equivalent key is available on the front panel.

:DATA:FEED:CONT

Syntax :DATA:FEED:CONTrol {BUF1|BUF2|BUF3},{ALWays|NEVer}
:DATA:FEED:CONTrol? {BUF1|BUF2|BUF3}

Description Determines whether to feed the measurement data into data buffer 1, data buffer 2, or data buffer 3.

Parameters

	Description
BUF1	Specifies data buffer 1 as the buffer to which the {ALWays NEVer} setup is applied or reads out the setup of data buffer 1.
BUF2	Specifies data buffer 2 as the buffer to which the {ALWays NEVer} setup is applied or reads out the setup of data buffer 2.
BUF3	Specifies data buffer 3 as the buffer to which the {ALWays NEVer} setup is applied or reads out the setup of data buffer 3.

	Description
ALWays	Feeds the measurement data into the data buffer specified with {BUF1 BUF2 BUF3} each time a measurement is performed.
NEVer (initial value)	Does not feed the measurement data into the data buffer specified with {BUF1 BUF2 BUF3}.

Query response {ALW|NEV}<newline><^END>

Related commands :DATA:FEED on page 173
:DATA:POIN on page 175

Equivalent key sequence No equivalent key is available on the front panel.

:DATA:POIN

Syntax :DATA:POINts {BUF1|BUF2|BUF3},<numeric>
:DATA:POINts? {BUF1|BUF2|BUF3}

Description Specifies the size of data buffer 1, data buffer 2, or data buffer 3 in number of measurements. Executing this command returns the pointer to the specified data buffer (the location to feed measurement data) back to the start.

Parameters

	Description
BUF1	Specifies data buffer 1 as the buffer to which the <numeric> setup is applied or reads out the setup of data buffer 1.
BUF2	Specifies data buffer 2 as the buffer to which the <numeric> setup is applied or reads out the setup of data buffer 2.
BUF3	Specifies data buffer 3 as the buffer to which the <numeric> setup is applied or reads out the setup of data buffer 3.

	<numeric>
Description	Number of measurements for the data buffer specified with {BUF1 BUF2 BUF3}
Range	Data buffer 1: 1 to 200 Data buffer 2: 1 to 200 Data buffer 3: 1 to 1000
Initial value	Data buffer 1: 200 Data buffer 2: 200 Data buffer 3: 1000
Resolution	1

If the specified parameter is out of the allowable setup range, the minimum value (if the lower limit of the range is not reached) or the maximum value (if the upper limit of the range is exceeded) is set.

MAX or MIN can be used to specify the parameters.

Query response {numeric}<newline><^END>

Related commands :DATA:FEED on page 173
:DATA:FEED:CONT on page 174

Equivalent key sequence No equivalent key is available on the front panel.

:DISP

:DISP

Syntax :DISPlay[:WINDow][:STATe] {ON|OFF|1|0}
:DISPlay[:WINDow][:STATe]?

Description Enables/disables the display of the measurement result.
If you disables the display, “DISP OFF” is always displayed on the screen.

Parameters

	Description
ON or 1 (initial value)	Enables the display.
OFF or 0	Disables the display.

Query response {1|0}<newline><^END>

Equivalent key sequence **[Disp Mode]([Blue] - [Freq]) - On/Off**

:DISP:TEXT1:DIG

Syntax :DISPlay[:WINDow]:TEXT1[:DATA]:DIGit <numeric>
:DISPlay[:WINDow]:TEXT1[:DATA]:DIGit?

Description Specifies the number of displayed digits for both the primary and secondary parameters.

Parameters

	<numeric>
Description	Number of displayed digits for the primary/secondary parameter
Range	4 to 6
Initial value	6
Unit	Digit
Resolution	1

If the specified parameter is out of the allowable setup range, the minimum value (if the lower limit of the range is not reached) or the maximum value (if the upper limit of the range is exceeded) is set.

MAX or MIN can be used to specify the parameters.

Query response {numeric}<newline><^END>

Equivalent key sequence **[Disp Mode]([Blue] - [Freq]) - Digit**

:DISP:TEXT1:FMSD

Syntax :DISPlay[:WINDow]:TEXT1[:DATA]:FMSD[:STATe] {ON|OFF|1|0}
 :DISPlay[:WINDow]:TEXT1[:DATA]:FMSD[:STATe]?

Description Determines whether to use the fixed point display when displaying both the primary and secondary parameters. In the following cases, the fixed point display is always used regardless of this setting (the value of the highest digit is also fixed).

- When displaying deviation as a percentage in the deviation measurement mode.
- When displaying the results of D and Q of the secondary parameter.

Parameters

	Description
ON or 1	Specifies the fixed point display.
OFF or 0 (initial value)	Specifies the floating point display.

Query response {1|0}<newline><^END>

Related commands :DISP:TEXT1:FMSD:DATA on page 178
 :CALC1:MATH:EXPR:NAME on page 148
 :CALC1:MATH:STAT on page 149
 :CALC2:MATH:EXPR:NAME on page 151
 :CALC2:MATH:STAT on page 152

Equivalent key sequence **[Disp Mode]([Blue] - [Freq]) - FixMsd - On/Off**

:DISP:TEXT1:FMSD:DATA

Syntax :DISPlay[:WINDow]:TEXT1[:DATA]:FMSD:DATA <numeric 1>,<numeric 2>
:DISPlay[:WINDow]:TEXT1[:DATA]:FMSD:DATA?

Description Sets the value of the highest digit when displaying both the primary and secondary parameters in the fixed point display. The parameter is always fixed to the same value, regardless of this setting, if the following conditions are met:

- Deviation is displayed as a percentage in the deviation measurement mode.
- The resulting D and Q of the secondary parameter is displayed.

Parameters

	<numeric 1>	<numeric 2>
Description	The value of the highest digit of the primary parameter.	The value of the highest digit of the secondary parameter.
Range	1E-12, 10E-12, 100E-12, 1E-9, 10E-9, 100E-9, 1E-6, 10E-6, 100E-6 (only the 9 points listed above)	1E-6, 10E-6, 100E-6, 1E-3, 10E-3, 100E-3, 1, 10, 100, 1E3, 10E3, 100E3, 1E6, 10E6, 100E6 (only the 15 points listed above)
Initial value	1E-9	1

If one of the settable values is not specified for the parameter, the minimum possible value, which is larger than the specified parameter value, is set. If the specified parameter exceeds the maximum value, the maximum value is set.

MAX or MIN can be used to specify the parameters.

Query response {numeric 1},{numeric 2}<newline><^END>

Related commands :DISP:TEXT1:FMSD on page 177
:CALC1:MATH:EXPR:NAME on page 148
:CALC1:MATH:STAT on page 149
:CALC2:MATH:EXPR:NAME on page 151
:CALC2:MATH:STAT on page 152

Equivalent key sequence **[Disp Mode]([Blue] - [Freq]) - FixMsd - MsdEnt**

:DISP:TEXT2:PAGE

Syntax :DISPlay[:WINDow]:TEXT2:PAGE <numeric>
:DISPlay[:WINDow]:TEXT2:PAGE?

Description Selects the page number of the instrument setup display area located on the right of the display. The correspondence between the page number and the displayed item is as follows:

Page number	Description of displayed item
1	Measurement frequency and measurement signal level.
2	Averaging count and cable length.
3	Measurement range and Trigger delay time.
4	Voltage/current monitor value of the measurement signal.
5	Load standard definition method (Single/Multi) and the selected channel number of the multi-compensation function.
6	Handler output (comparator result).
7	Lower and Upper limits of BIN1.
8	Lower and Upper limits of BIN2.
9	Lower and Upper limits of BIN3.
10	Lower and Upper limits of BIN4.
11	Lower and Upper limits of BIN5.
12	Lower and Upper limits of BIN6.
13	Lower and Upper limits of BIN7.
14	Lower and Upper limits of BIN8.
15	Lower and Upper limits of BIN9.
16	Lower and Upper limits of the secondary parameter.
17	Limit modes and reference values for BIN1 to BIN9.
18	On/off state of the AUX BIN function.
19	Count values of BIN1 and BIN2.
20	Count values of BIN3 and BIN4.
21	Count values of BIN5 and BIN6.
22	Count values of BIN7 and BIN8.
23	Count values of BIN9 and AUX BIN.
24	Count values of OUT OF BINS and OVLD.

Page number	Description of displayed item
25	OPEN compensation data (primary parameter)
26	OPEN compensation data (secondary parameter)
27	SHORT compensation data (primary parameter)
28	SHORT compensation data (secondary parameter)
29	LOAD compensation data (primary parameter)
30	LOAD compensation data (secondary parameter)
31	LOAD compensation standard definition value (primary parameter)
32	LOAD compensation standard definition value (secondary parameter)
33	OFFSET compensation data (primary parameter)
34	OFFSET compensation data (secondary parameter)

Parameters

	<numeric>
Description	Page number
Range	1 to 34
Initial value	1
Resolution	1

If the specified parameter is out of the allowable setup range, the minimum value (if the lower limit of the range is not reached) or the maximum value (if the upper limit of the range is exceeded) is set.

MAX or MIN can be used to specify the parameters.

Query response {numeric}<newline><^END>

Equivalent key sequence **[Show Setting]** and [↑ →] / [← ↓]

:FETC?

Syntax	:FETCh?
Description	<p>Reads out the measurement result. The target measurement to read out depends on the state of the 4288A.</p> <ul style="list-style-type: none"> • During measurement: Waits for end of the measurement and then reads out its result. • Other states: Reads out the result of the immediately preceding measurement. <p>If overload is detected (that is, the measurement status is 1), the measured values of the primary parameter and secondary parameter are 9.9E37 and the comparator sorting result is 11.</p> <p>The transfer format of data read out with this command conforms to the setup made with the :FORM command. (Query only)</p>
Query response	<p>{numeric 1},{numeric 2},{numeric 3},{numeric 4}<newline><^END></p> <p>Note that if the comparator function is disabled (OFF has been specified with the :CALC:COMP command), only three data items, {numeric1}, {numeric2}, and {numeric3}, are read out.</p> <p>{numeric 1}, {numeric 2}, {numeric 3}, and {numeric 4} are as follows:</p> <p style="padding-left: 40px;">{numeric 1}: Measurement status (one of the integers between 0 and 2 listed below)</p> <p style="padding-left: 80px;">0: No error 1: Detection of overload (OVL D) 2: Detection of Low C</p> <p style="padding-left: 40px;">{numeric 2}: Measured value of the primary parameter</p> <p style="padding-left: 40px;">{numeric 3}: Measured value of the secondary parameter</p> <p style="padding-left: 40px;">{numeric 4}: Comparator sorting result (an integer between 0 and 11 listed below)</p> <p style="padding-left: 80px;">0: Sorted into OUT_OF_BINS. 1: Sorted into BIN1. 2: Sorted into BIN2. 3: Sorted into BIN3. 4: Sorted into BIN4. 5: Sorted into BIN5. 6: Sorted into BIN6. 7: Sorted into BIN7. 8: Sorted into BIN8. 9: Sorted into BIN9. 10: Sorted into AUX_BIN. 11: BIN_NA (sorting impossible)</p>
Related commands	<p>:READ? on page 186</p> <p>*TRG on page 128</p> <p>:FORM on page 182</p> <p>:CALC:COMP on page 134</p>
Equivalent key sequence	No equivalent key is available on the front panel.

:FORM

Syntax :FORMat[:DATA] { ASCii|REAL[,64]}
:FORMat[:DATA]?

Description Sets the transfer format of data read out using the following commands:

- :FETC? on page 181
- :READ? on page 186
- *TRG on page 128
- :DATA on page 168
- :CORR:DATA on page 158

For details on the data transfer formats, refer to “Data Transfer Format” on page 58.

Parameters

	Description
ASCii (initial value)	Specifies the ASCII data transfer format.
REAL	Specifies the 64-bit real number data transfer format.

Query response {ASC|REAL,64}<newline><^END>

Equivalent key sequence No equivalent key is available on the front panel.

:INIT

Syntax :INITiate[:IMMediate]

Description Starts the trigger system once.

If the trigger system is in the idle state, executing this command starts the trigger system and, after measurement is executed once, returns the instrument to the idle state.

If the trigger system is not in the idle state or successive startup of the trigger system is enabled (set to ON with the **:INIT:CONT** command), executing this command causes an error and the command is ignored.

For details on the trigger system, refer to “Trigger system” on page 52. (No query)

Related commands :INIT:CONT on page 183

Equivalent key sequence No equivalent key is available on the front panel.

:INIT:CONT

Syntax :INITiate:CONTinuous {ON|OFF|1|0}
:INITiate:CONTinuous?

Description Determines whether to start up the trigger system successively.

For details on the trigger system, refer to “Trigger system” on page 52.

Parameters

	Description
ON or 1 (initial value)	Enables successive startup.
OFF or 0	Disables successive startup.

This setup is initialized to ON when using the **:SYST:PRES** command and to OFF when using the ***RST** command.

Query response {1|0}<newline><^END>

Related commands *RST on page 126

Equivalent key sequence No equivalent key is available on the front panel.

:RANG

Syntax [:SENSe][:FIMPedance]:RANGe[:UPPer] <numeric>[PF|P|NF|N|UF|U|MF|M|F]
[:SENSe][:FIMPedance]:RANGe[:UPPer]?

Description Sets the measurement range.
With the measurement frequency and the measurement range set to 1 MHz and 47E-12 (47p) or less, respectively, changing the measurement frequency to 1 kHz will automatically set the measurement range to 100E-12 (100p). On the other hand, with the measurement frequency and the measurement range set to 1 kHz and 2.2E-9 (2.2n) or more, respectively, changing the measurement frequency to 1 MHz will automatically set the measurement range to 1E-9 (1n).

When you set the measurement range with this command, the measurement range mode is automatically set to the hold range (specified to OFF with the **:RANG:AUTO** command).

Parameters

	<numeric>
Description	Measurement range
Range	When the measurement frequency is 1 kHz: 100E-12(100PF), 220E-12(220PF), 470E-12(470PF), 1E-9(1NF), 2.2E-9(2.2NF), 4.7E-9(4.7NF), 10E-9(10NF), 22E-9(22NF), 47E-9(47NF), 100E-9(100NF), 220E-9(220NF), 470E-9(470NF), 1E-6(1UF), 2.2E-6(2.2UF), 4.7E-6(4.7UF), 10E-6(10UF) (only the 16 points listed above). When the measurement frequency is 1 MHz: 1E-12(1PF), 2.2E-12(2.2PF), 4.7E-12(4.7PF), 10E-12(10PF), 22E-12(22PF), 47E-12(47PF), 100E-12(100PF), 220E-12(220PF), 470E-12(470PF), 1E-9(1NF) (only the 10 points listed above).
Initial value	10E-6

If one of the settable values is not specified for the parameter, a suitable measurement range whose recommended range includes the specified parameter (for example, 4.7E-9 if the specified parameter is 5E-9) is set.

MAX or MIN can be used to specify the parameters.

Query response { 1E-12|2.2E-12|4.7E-12|100E-12|220E-12|470E-12|1E-9|2.2E-9|4.7E-9|10E-9|22E-9|47E-9|100E-9|220E-9|470E-9|1E-6|2.2E-6|4.7E-6|10E-6 }<newline><^END>

If the measurement range mode is Auto, the measurement range used in the immediately preceding measurement is read out as the query response.

Related commands :RANG:AUTO on page 185

Equivalent key sequence [Range Setup]([Blue] - [Auto/Hold])

:RANG:AUTO

Syntax [:SENSe][:FIMPedance]:RANGe:AUTO {ON|OFF|1|0}
[:SENSe][:FIMPedance]:RANGe:AUTO?

Description Selects the measurement range mode from the auto range (automatic range switching) or hold range (fixed range).
Setting the measurement range (set with the **:RANG** command) automatically selects the hold range mode.

Parameters

	Description
ON or 1 (initial value)	Specifies the auto range mode.
OFF or 0	Specifies the hold range mode.

Query response {1|0}<newline><^END>

Related commands :RANG on page 184

Equivalent key sequence **[Auto/Hold]**

:READ?

Syntax	:READ?
Description	<p>Waits for the end of measurement and reads out the measurement result.</p> <p>Executing this command brings the 4288A into the trigger wait state. When the trigger system is in the idle state, this command invokes the trigger system (the :INIT command) once and then brings the instrument into the trigger wait state. After that, when the instrument is triggered and the measurement finishes, this command reads the measurement result and exits.</p> <p>This command can be executed when the trigger mode has been set to either internal (Int) or external (Ext) (set to INT or EXT with the :TRIG:SOUR command).</p> <p>If this command is executed with the trigger mode set to manual (Man) or GPIB (Bus) (specified as MAN or BUS with the :TRIG:SOUR command), an error occurs because there is no way to trigger and the command is ignored.</p>
NOTE	<p>If the trigger mode is External (Ext), no subsequent command can be accepted until an external trigger is supplied. To release this state without entering an external trigger, send Device Clear (the “CLEAR” instruction in HTBasic) to the GPIB port to abort the query operation.</p> <p>The transfer format of data read out with this command conforms to the setup made with the :FORM command. (Query only)</p>
Query response	<p>{numeric 1},{numeric 2},{numeric 3},{numeric 4}<newline><^END></p> <p>The query response is the same as that of the :FETC? command. For details, refer to the description of :FETC?.</p>
Related commands	<p>:FETC? on page 181</p> <p>*TRG on page 128</p> <p>:INIT on page 183</p> <p>:TRIG:SOUR on page 196</p> <p>:FORM on page 182</p>
Equivalent key sequence	No equivalent key is available on the front panel.

:SOUR:FREQ

Syntax :SOURce:FREQuency[:CW] <numeric>[HZ|KHZ|K]
 :SOURce:FREQuency[:CW]?

Description Sets the measurement frequency.
 Depending on this setting, the available measurement range varies (set with the **:RANG** command). If changing the measurement frequency results in a conflict with the measurement range setting, an acceptable range is automatically selected.

Parameters

	<numeric>
Description	Measurement frequency
Range	1E3 and 1E6: 2 points only
Initial value	1E3

If the specified parameter is less than 500E3, 1 kHz is set; if it is 500E3 or more, 1 MHz is set.

MAX or MIN can be used to specify the parameters.

Query response {1E3|1E6}<newline><^END>

Related commands :RANG on page 184

Equivalent key sequence **[Freq]**

:SOUR:VOLT

Syntax :SOURce:VOLTage[:LEVel][:IMMediate][:AMPLitude] <numeric>[MV|M|V]
 :SOURce:VOLTage[:LEVel][:IMMediate][:AMPLitude]?

Description Sets the measurement signal level.

Parameters

	<numeric>
Description	Measurement signal level
Range	100E-3 to 1
Initial value	1
Unit	V
Resolution	0.1

If the specified parameter is out of the allowable setup range, the minimum value (if the lower limit of the range is not reached) or the maximum value (if the upper limit of the range is exceeded) is set. Note that a fraction below the resolution is rounded off.

MAX or MIN can be used to specify the parameters.

Query response {numeric}<newline><^END>

Equivalent key sequence **[Level]**

:STAT:OPER?

Syntax	:STATus:OPERation[:EVENT]?
Description	Reads out the value of the Operation Status Event register. (Query only)
Query response	{numeric}<newline><^END>
Related commands	*CLS on page 124
Equivalent key sequence	No equivalent key is available on the front panel.

:STAT:OPER:COND?

Syntax	:STATus:OPERation:CONDition?
Description	Reads out the value of the Operation Status Condition register. (Query only)
Query response	{numeric}<newline><^END>
Equivalent key sequence	No equivalent key is available on the front panel.

:STAT:OPER:ENAB

Syntax	:STATus:OPERation:ENABle <numeric> :STATus:OPERation:ENABle?
Description	Sets the value of the Operation Status Enable register.
Parameters	

	<numeric>
Description	The value of the Enable register.
Range	0 to 32767
Initial value	0
Resolution	1

If the specified parameter is out of the allowable setup range, the result of bit-by-bit logical AND with 32767 (0x7fff) is set.

Query response	{numeric}<newline><^END>
Related commands	*SRE on page 127 :STAT:PRES on page 190
Equivalent key sequence	No equivalent key is available on the front panel.

:STAT:PRES

Syntax	:STATus:PRESet
Description	Initializes the Operation Status register and the Questionable Status register. (No query)
Equivalent key sequence	No equivalent key is available on the front panel.

:STAT:QUES?

Syntax	:STATus:QUEStionable[:EVENTt]?
Description	Reads out the value of the Questionable Status Event register. (Query only)
Query response	{numeric}<newline><^END> The 4288A does not support the Questionable Status register. Therefore, the query response is always 0.
Equivalent key sequence	No equivalent key is available on the front panel.

:STAT:QUES:COND?

Syntax	:STATus:QUEStionable:CONDition?
Description	Reads out the value of the Questionable Status Condition register. (Query only)
Query response	{numeric}<newline><^END> The 4288A does not support the Questionable Status register. Therefore, the query response is always 0.
Equivalent key sequence	No equivalent key is available on the front panel.

:STAT:QUES:ENAB

Syntax	:STATus:QUEStionable:ENABle <numeric> :STATus:QUEStionable:ENABle?
Description	Sets the value of the Questionable Status Enable register. However, the 4288A does not support the Questionable Status register. Therefore, executing this command has no effect.
Query response	{numeric}<newline><^END>
Equivalent key sequence	No equivalent key is available on the front panel.

:SYST:BEEP

Syntax :SYSTem:BEEPer[:IMMEDIATE]

Description Produces a beep sound.

If the beep sound is disabled (OFF has been specified with the **:SYST:BEEP:STAT** command), no beep sound is produced even if you execute this command. (No query)

Related commands :SYST:BEEP:STAT on page 191

Equivalent key sequence No equivalent key is available on the front panel.

:SYST:BEEP:STAT

Syntax :SYSTem:BEEPer:STATe {ON|OFF|1|0}

:SYSTem:BEEPer:STATe?

Description Turns ON/OFF the beep output.

This command has the same function as the **:CALC:COMP:BEEP** command.

Parameters

	Description
ON or 1 (initial value)	Enables the beep sound.
OFF or 0	Disables the beep sound.

Query response {1|0}<newline><^END>

Related commands :CALC:COMP:BEEP on page 135

Equivalent key sequence **[Config]([Blue] - [-]) - Beep**

:SYST:ERR?

:SYST:ERR?

- Syntax** :SYSTem:ERRor?
- Description** Reads out the oldest error remaining in the 4288A's error queue. The size of the error queue is 10.
Executing the ***CLS** command clears errors stored in the error queue. (Query only)
- Query response** {numeric},{string}<newline><^END>
{numeric}: Error number
{string}: Error message (a string within double quotation marks (“”))
If no error is stored in the error queue, 0 is read out as the error number and “No error” as the error message.
- Related commands** *CLS on page 124
- Equivalent key sequence** No equivalent key is available on the front panel.

:SYST:FSH

- Syntax** :SYSTem:FSHift <numeric>
:SYSTem:FSHift?
- Description** When you make a measurement with the measurement frequency set to 1 MHz, specifies the shift of the signal frequency (frequency shift value) actually applied to the DUT relative to 1 MHz as a percentage of 1 MHz.
- Parameters**

	<numeric>
Description	The value of the frequency shift.
Range	-1 to 2
Initial value	0
Unit	% (percent)
Resolution	1

If the specified parameter is out of the allowable setup range, the minimum value (if the lower limit of the range is not reached) or the maximum value (if the upper limit of the range is exceeded) is set. Note that a fraction below the resolution is rounded off.

MAX or MIN can be used to specify the parameters.

- Query response** {numeric}<newline><^END>
- Equivalent key sequence** **[Config]([Blue] - [-]) - Fshft**

:SYST:KLOC

Syntax :SYSTem:KLOCK {ON|OFF|1|0}
 :SYSTem:KLOCK?

Description Locks or unlocks the front panel keys.

Parameters

	Description
ON or 1	Locks the keys.
OFF or 0 (initial value)	Unlocks the keys.

Query response {1|0}<newline><^END>

Equivalent key sequence **[Key Lock]([Blue] - [0])**

:SYST:PRES

Syntax :SYSTem:PRESet

Description Resets the instrument to the preset state.

The preset state is different from that when resetting is done by using the ***RST** command. For details, refer to Appendix D, “Initial Settings.” (No query)

Related commands *RST on page 126

Equivalent key sequence **[Reset]([Blue] - [.]) - Yes**

:SYST:TEST?

Syntax	:SYSTem:TEST?
Description	Executes the external test and reads out its result. (Query only)
NOTE	<p>Before executing the command, connect the 42090A to the UNKNOWN terminal of the 4288A (or directly connect between L_{CUR} and L_{POT} and between H_{CUR} and H_{POT} with BNC cables).</p> <p>For more information on the external test, refer to <i>4288A Service Manual</i>.</p>
Query response	<p>{numeric 1},{numeric 2},{numeric 3},{numeric 4},{numeric 5}<newline><^END></p> <p>For a test item that fails, the following information is read out. When all of the test items pass, all read-out values are 0.</p> <p>{numeric 1}: Test number (an integer ranging from 1 to 4 as shown below)</p> <p style="padding-left: 40px;">1: Entire analog circuitry 2: Signal part (signal level) 3: Signal part (frequency) 4: Measurement part</p> <p>{numeric 2}: Setting number for each test (an integer ranging from 1 to 10. Refer to <i>4288A Service Manual</i>.)</p> <p>{numeric 3}: Measurement item (an integer between 1 and 3 as shown below)</p> <p style="padding-left: 40px;">1: Absolute value of impedance 2: Voltage level of measurement signal 3: Current level of measurement signal</p> <p>{numeric 4}: Expected value of measurement item</p> <p>{numeric 5}: Measured value of measurement item</p>
Related commands	*TST? on page 129
Equivalent key sequence	[Config] ([Blue] - [-]) - Test - External - Yes

:SYST:VERS?

Syntax	:SYSTem:VERSion?
Description	Returns the SCPI version number of the instrument. (Query only)
Query response	<p>{string}<newline><^END></p> <p>The readout data format is YYYY.V, where YYYY indicates the version year and V indicates the version number within that year.</p>
Equivalent key sequence	No equivalent key is available on the front panel.

:TRIG

- Syntax** :TRIGger[:SEQuence1][:IMMediate]
- Description** Immediately generates a trigger and executes a measurement regardless of the setup of the trigger mode.
- If the trigger system is not in the trigger wait state (trigger event detection state), executing this command causes an error and the command is ignored.
- For details on the trigger system, refer to “Trigger system” on page 52. (No query)

Equivalent key sequence No equivalent key is available on the front panel.

:TRIG:DEL

- Syntax** :TRIGger[:SEQuence1]:DELay <numeric>[MS|M|S]
:TRIGger[:SEQuence1]:DELay?
- Description** Specifies the waiting time between when a trigger is inputted and when the measurement starts (trigger delay time).

Parameters

	<numeric>
Description	Trigger delay time
Range	0 to 1
Initial value	0
Unit	s (second)
Resolution	1E-3

If the specified parameter is out of the allowable setup range, the minimum value (if the lower limit of the range is not reached) or the maximum value (if the upper limit of the range is exceeded) is set. Note that a fraction below the resolution is rounded off.

MAX or MIN can be used to specify the parameters.

Query response {numeric}<newline><^END>

Equivalent key sequence [Delay]([Blue] - [Trig Mode])

:TRIG:SOUR

Syntax :TRIGger[:SEQuence1]:SOURce {INTernal|MANual|EXTernal|BUS}
:TRIGger[:SEQuence1]:SOURce?

Description Selects the trigger mode from the following four types.

Internal	Configures the instrument to use its internal trigger source so that is it automatically and continuously triggered.
Manual	Configures the instrument to be triggered when you press the [Trig] key on the front panel.
External	Configures the instrument to be triggered when a trigger signal is inputted through the Ext TRIG terminal or handler/scanner interface.
GPIB (Bus)	Configures the instrument to be triggered when the *TRG command is executed.

Parameters

	Description
INTernal (initial value)	Specifies Internal.
MANual	Specifies Manual.
EXTernal	Specifies External.
BUS	Specifies GPIB (Bus).

Query response {INT|MAN|EXT|BUS}<newline><^END>

Related commands *TRG on page 128

Equivalent key sequence **[Trig Mode]**
Note that you cannot set the trigger mode to GPIB (Bus) using the front panel keys.

GPIB Command Table

Table 10-2 lists the 4288A GPIB commands sorted according to function

Table 10-2

GPIB Command Table

Function	Item to Be Set Up/Executed		GPIB command
Measurement condition	Reset		:SYST:PRES on page 193, *RST on page 126
	Measurement parameter setup	Primary parameter	:CALC1:FORM on page 147
		Secondary parameter	:CALC2:FORM on page 150
	Measurement signal setup	Frequency	:SOUR:FREQ on page 187
		1 MHz frequency shift	:SYST:FSH on page 192
		Level	:SOUR:VOLT on page 188
	Measurement range setup	Ranging (auto/manual)	:RANG:AUTO on page 185
		Range	:RANG on page 184
	Measurement time mode setup		:APER on page 130
	Averaging setup	ON/OFF	:AVER on page 131
		Number of counts	:AVER:COUN on page 132
	Cable length setup		:CAL:CABL on page 133
	Trigger delay setup		:TRIG:DEL on page 195
	Trigger mode setup		:TRIG:SOUR on page 196
Compensation	OPEN compensation ON/OFF		:CORR:OPEN on page 165
	SHORT compensation ON/OFF		:CORR:SHOR on page 165
	LOAD compensation ON/OFF		:CORR:LOAD on page 160
	Offset compensation ON/OFF		:CORR:OFFS on page 163
	OPEN compensation data parameter format		:CORR:CKIT:STAN1:FORM on page 154
	SHORT compensation data parameter format		:CORR:CKIT:STAN2:FORM on page 154
	LOAD standard definition	Value setup	:CORR:CKIT:STAN3 on page 155
		Definition parameter format	:CORR:CKIT:STAN3:FORM on page 156
	Compensation data	Measurement	:CORR:COLL on page 157
		setup and read out	:CORR:DATA on page 158
Offset compensation data setup		:CORR:OFFS:DATA on page 164	
Scanner (multi compensation)	ON/OFF		:CORR:MULT on page 161
	Channel setup		:CORR:MULT:CHAN on page 161
	LOAD standard definition method setup		:CORR:MULT:CKIT:STAN3 on page 162

Table 10-2 GPIB Command Table

Function	Item to Be Set Up/Executed		GPIB command
Trigger	Triggers a measurement		:TRIG on page 195, *TRG on page 128
	Trigger mode setup		:TRIG:SOUR on page 196
	Trigger delay time setup		:TRIG:DEL on page 195
	Trigger system	Resets	:ABOR on page 130
		Initiates	:INIT on page 183
Continuous activation ON/OFF		:INIT:CONT on page 183	
Measured data output	Data transfer format setup		:FORM on page 182
	Data readout	Measurement result	:FETC? on page 181, :READ? on page 186
		Data buffer	:DATA? {BUF1 BUF2 BUF3} on page 168
		Measurement signal monitor result	:DATA? {IMON VMON} on page 171
	Data buffer setup	Feeding target parameter	:DATA:FEED on page 173
		Control (feed/not feed)	:DATA:FEED:CONT on page 174
		Buffer size	:DATA:POIN on page 175
Comparator	ON/OFF		:CALC:COMP on page 134
	Limit range reset		:CALC:COMP:CLE on page 136
	Primary parameter limit range setup	ON/OFF	:CALC:COMP:PRIM:BIN{1-9}:STAT on page 143
		Lower/Upper Limit value	:CALC:COMP:PRIM:BIN{1-9} on page 142
		Limit range designation method (mode selection)	:CALC:COMP:MODE on page 141
		Reference (nominal) value	:CALC:COMP:PRIM:NOM on page 144
	Secondary parameter limit range setup	ON/OFF	:CALC:COMP:SEC:STAT on page 146
		Lower/Upper Limit value	:CALC:COMP:SEC:LIM on page 145
	AUX BIN function ON/OFF		:CALC:COMP:AUXB on page 135
	Low C reject function	ON/OFF	:CREJ on page 166
		Limit value setup	:CREJ:LIM on page 167
	BIN count function	ON/OFF	:CALC:COMP:COUN on page 137
		Resets all count values	:CALC:COMP:COUN:CLE on page 137
		Readout of count values	:CALC:COMP:COUN:DATA? on page 138
		Readout of count value of overload	:CALC:COMP:COUN:OVLD? on page 140
		Readout of count values for each channel	:CALC:COMP:COUN:MULT:DATA? on page 139
		Readout of count value of overload for each channel	:CALC:COMP:COUN:MULT:OVLD? on page 140

Table 10-2 GPIB Command Table

Function	Item to Be Set Up/Executed		GPIB command	
Measurement signal monitor	Current monitor	ON/OFF	:CALC3:MATH:STAT on page 153	
		Monitor value readout	:DATA? {IMON VMON} on page 171	
	Voltage monitor	ON/OFF	:CALC4:MATH:STAT on page 153	
		Monitor value readout	:DATA? {IMON VMON} on page 171	
Save/Recall	Save		*SAV on page 127	
	Recall		*RCL on page 126	
Display	ON/OFF		:DISP on page 176	
	Number of digits setup		:DISP:TEXT1:DIG on page 176	
	Fixed point display setup	ON/OFF	:DISP:TEXT1:FMSD on page 177	
		value of the highest digit	:DISP:TEXT1:FMSD:DATA on page 178	
	Deviation measurement mode setup	Primary parameter	ON/OFF	:CALC1:MATH:STAT on page 149
			Mode	:CALC1:MATH:EXPR:NAME on page 148
		Secondary parameter	ON/OFF	:CALC2:MATH:STAT on page 152
			Mode	:CALC2:MATH:EXPR:NAME on page 151
	Reference value		:DATA {REF1 REF2} on page 172	
Setup of displayed page of the instrument setup display area		:DISP:TEXT2:PAGE on page 179		
Key lock	ON/OFF		:SYST:KLOC on page 193	
Beeper	ON/OFF		:CALC:COMP:BEEP on page 135, :SYST:BEEP:STAT on page 191	
	Beep mode setup		:CALC:COMP:BEEP:COND on page 136	
	Generation of a beep		:SYST:BEEP on page 191	
Status report structure	Clear		*CLS on page 124	
	Status byte register value readout		*STB? on page 128	
	Service request enable register setup		*SRE on page 127	
	Standard event status register	Register value readout		*ESR? on page 125
		OPC bit setup		*OPC on page 125
		Enable register setup		*ESE on page 124
	Operation status register	Clear		:STAT:PRES on page 190
		Condition register value readout		:STAT:OPER:COND? on page 189
Enable register setup		:STAT:OPER:ENAB on page 189		
Event register value readout		:STAT:OPER? on page 189		

Table 10-2

GPIB Command Table

Function	Item to Be Set Up/Executed		GPIB command
Others	1 MHz frequency shift setup		:SYST:FSH on page 192
	Executes self-test	Internal	*TST? on page 129
		External	:SYST:TEST? on page 194
	Readout of the model name and firmware version		*IDN? on page 125
	Readout of the installed option number		*OPT? on page 126
	Reads 1 when operation completes		*OPC? on page 125
	Readout of the occurred error information		:SYST:ERR? on page 192
	Readout of SCPI version		:SYST:VERS? on page 194
	Waits for completion of operation		*WAI on page 129

Front Panel Key Tree vs. GPIB Command

Table 10-3 shows the commands that correspond to operation of the front panel keys.

Table 10-3 Front panel key tree vs. GPIB command

Key operation		GPIB command	
[Adrs]		Nothing	
[Auto/Hold]		:RANG:AUTO on page 185	
[Average]		:AVER on page 131 :AVER:COUN on page 132	
[Cable]		:CAL:CABL on page 133	
[Comprtr]	On/Off	:CALC:COMP on page 134	
	Aux	:CALC:COMP:AUXB on page 135	
	Limit	Pri	:CALC:COMP:PRIM:BIN{1-9} on page 142 :CALC:COMP:PRIM:BIN{1-9}:STAT on page 143
		Sec	:CALC:COMP:SEC:LIM on page 145 :CALC:COMP:SEC:STAT on page 146
		Δ Mode	:CALC:COMP:MODE on page 141 :CALC:COMP:PRIM:NOM on page 144
		Clr	:CALC:COMP:CLE on page 136
	Count	Off	:CALC:COMP:COUN on page 137
		On	
CountClear		:CALC:COMP:COUN:CLE on page 137	
[Config]	Fshft	:SYST:FSH on page 192	
	Beep		:SYST:BEEP:STAT on page 191 :CALC:COMP:BEEP on page 135 :CALC:COMP:BEEP:COND on page 136
	Test	Internal	*TST? on page 129
		External	:SYST:TEST? on page 194
Rev		*IDN? on page 125	
[Delay]		:TRIG:DEL on page 195	
[Δ Mode]	Pri	:CALC1:MATH:STAT on page 149 :CALC1:MATH:EXPR:NAME on page 148	
	Sec	:CALC2:MATH:STAT on page 152 :CALC2:MATH:EXPR:NAME on page 151	
	ΔRefEnt	:DATA {REF1 REF2} on page 172	
[Disp Mode]	On/Off	:DISP on page 176	
	Digit	:DISP:TEXT1:DIG on page 176	
	FixMsd	On/Off	:DISP:TEXT1:FMSD on page 177
		MsdEnt	:DISP:TEXT1:FMSD:DATA on page 178
[Freq]		:SOUR:FREQ on page 187	
[Key Lock]		:SYST:KLOC on page 193	
[Lcl]		Nothing (LOCAL command of HTBasic)	
[Level]		:SOUR:VOLT on page 188	

Table 10-3 Front panel key tree vs. GPIB command

Key operation			GPIB command
[Level Mon]			:CALC3:MATH:STAT on page 153 :CALC4:MATH:STAT on page 153
[Load]	On/Off		:CORR:LOAD on page 160
	LoadMeas		:CORR:COLL on page 157
	CorVal	PrmSlct	:CORR:CKIT:STAN3:FORM on page 156
		RefEnt	:CORR:CKIT:STAN3 on page 155
MeasVal		:CORR:DATA on page 158	
[Low C Rej]	On/Off		:CREJ on page 166
	Limit		:CREJ:LIM on page 167
[Meas Prmtr]			:CALC1:FORM on page 147 :CALC2:FORM on page 150
[Meas Time]			:APER on page 130
[Offset]	On/Off		:CORR:OFFS on page 163
	OfsEnt		:CORR:OFFS:DATA on page 164
[Open]	On/Off		:CORR:OPEN on page 165
	OpenMeas		:CORR:COLL on page 157
	CorVal	PrmSlct	:CORR:CKIT:STAN1:FORM on page 154
		MeasVal	:CORR:DATA on page 158
[Pri High]			:CALC:COMP:PRIM:BIN1 on page 142
[Pri Low]			
[Range Setup]			:RANG on page 184
[Rcl]			*RCL on page 126
[Reset]			:STAT:PRES on page 190
[Save]			*SAV on page 127
[Scanner]	On/Off		:CORR:MULT on page 161
	Channel		:CORR:MULT:CHAN on page 161
	LoadRef		:CORR:MULT:CKIT:STAN3 on page 162
[Sec High]			:CALC:COMP:SEC:LIM on page 145
[Sec Low]			
[Short]	On/Off		:CORR:SHOR on page 165
	ShortMeas		:CORR:COLL on page 157
	CorVal	PrmSlct	:CORR:CKIT:STAN2:FORM on page 154
		MeasVal	:CORR:DATA on page 158
[Show Setting]			:DISP:TEXT2:PAGE on page 179
[Trig]			:TRIG on page 195
[Trig Mode]			:TRIG:SOUR on page 196

GPIB Command Tree

Table 10-4 shows the 4288A GPIB command tree.

Table 10-4 4288A GPIB command tree

Command	Parameter	Note
ABORt		[No query]
CALCulate		
:COMParator		
:AUXBin	{ON OFF 1 0}	
:BEEPer		
:CONDition	{PASS FAIL}	
[:STATe]	{ON OFF 1 0}	
:CLEar		[No query]
:COUNT		
:CLEar		[No query]
:DATA?		[Query only]
:MUTLi		
:DATA?		[Query only]
:OVLd?		[Query only]
:OVLd?		[Query only]
[:STATe]	{ON OFF 1 0}	
:MODE	{ABS DEV PCNT}	
:PRIMary		
:BIN1	<numeric>,<numeric>	
:STATe	{ON OFF 1 0}	
:BIN{2 3 4 5 6 7 8 9}	<numeric>,<numeric>	
:STATe	{ON OFF 1 0}	
:NOMinal	<numeric>	
:SECOndary		
:LIMit	<numeric>,<numeric>	
:STATe	{ON OFF 1 0}	
[:STATe]	{ON OFF 1 0}	
CALCulate1		
:FORMat	{CP CS}	
:MATH		
:EXPRession		
:CATalog?		[Query only]
:NAME	{DEV PCNT}	
:STATe	{ON OFF 1 0}	
CALCulate2		
:FORMat	{D Q G RP RS}	
:MATH		
:EXPRession		
:CATalog?		[Query only]
:NAME	{DEV PCNT}	
:STATe	{ON OFF 1 0}	
CALCulate3		
:MATH		
:STATe	{ON OFF 1 0}	

Table 10-4 4288A GPIB command tree

Command	Parameter	Note
CALCulate4		
:MATH		
:STATe	{ON OFF 1 0}	
CALibration		
:CABLe	<numeric>	
DATA		
[:DATA]	{REF1 REF2},<numeric>	
[:DATA]?	{BUF1 BUF2}	[Query only]
:FEED	{IMON VMON}	[Query only]
:CONTRol	{BUF1 BUF2},{ "CALCulate1" "CALCulate2" ""}	
:POINts	{BUF1 BUF2},<numeric>	
DISPlay		
[:WINDow]		
[:STATe]	{ON OFF 1 0}	
:TEXT1		
[:DATA]		
:DIGit	<numeric>	
:FMSD		
:DATA	<numeric>	
[:STATe]	{ON OFF 1 0}	
:TEXT2		
:PAGE	<numeric>	
FETCh?		[Query only]
FORMat		
[:DATA]	{ASCIi REAL[,64]}	
INITiate		
:CONTInuous	{ON OFF 1 0}	
[:IMMediate]		[No query]
READ?		[Query only]

Table 10-4 4288A GPIB command tree

Command	Parameter	Note
[SENSe]		
:AVERage		
:COUNT	<numeric>	
[:STATe]	{ON OFF 1 0}	
[:FIMPedance]		
:APERture		
[:MODE]	{SHORT MEDIUM LONG}	
:CREJect		
:LIMit	<numeric>	
[:STATe]	{ON OFF 1 0}	
:RANGe		
:AUTO	{ON OFF 1 0}	
[:UPPer]	<numeric>{PF P NF N UF U MF M F}	
:CORRection		
:CKIT		
:STANdard1		
:FORMat	{GB CPG}	
:STANdard2		
:FORMat	{RX LSRS}	
:STANdard3	<numeric>,<numeric>	
:FORMat	{CPD CPQ CPG CPRP CSD CSQ CSRS}	
:COLLect		
[:ACQuire]	{STANdard1 STANdard2 STANdard3} [No query]	
:DATA	{STANdard1 STANdard2 STANdard3},<numeric>	
:LOAD		
[:STATe]	{ON OFF 1 0}	
:MULTiple		
:CHANnel	<numeric>	
:CKIT		
:STANdard3		
[:STATe]	{ON OFF 1 0}	
[:STATe]	{ON OFF 1 0}	
:OFFSet		
:DATA	<numeric>,<numeric>	
[:STATe]	{ON OFF 1 0}	
:OPEN		
[:STATe]	{ON OFF 1 0}	
:SHORT		
[:STATe]	{ON OFF 1 0}	
SOURce		
:FREQuency		
[:CW]	<numeric>{HZ KHZ K}	
:VOLTage		
[:LEVel]		
[:IMMediate]		
[:AMPLitude]	<numeric>{MV M V}	

Table 10-4 4288A GPIB command tree

Command	Parameter	Note
STaTus		
:OPERation		
:CONDition?		[Query only]
:ENABle	<numeric>	
[:EVENt]?		[Query only]
:PRESet		[No query]
:QUEStionable		
:CONDition?		[Query only]
:ENABle	<numeric>	
[:EVENt]?		[Query only]
SYSTem		
:BEEPer		
[:IMMediate]		[No query]
:STATe	{ON OFF 1 0}	
:ERRor?		[Query only]
:KLOCK	{ON OFF 1 0}	
:FSHift	<numeric>	
:PRESet		[No query]
:TEST?		[Query only]
:VERSion?		[Query only]
TRIGger		
[:SEQuence1]		
:DELay	<numeric>[MS M S]	
[:IMMediate]		[No query]
:SOURce	{INTernal MANual EXTernal BUS}	

A **Manual Changes**

This appendix contains the information required to adapt this manual to earlier versions or configurations of the Agilent 4288A than that indicated by the current printing date of this manual. The information in this manual applies directly to the 4288A model that has the serial number prefix listed on the title page of this manual.

Manual Changes

To adapt this manual to your Agilent 4288A, refer to Table A-1 and Table A-2.

Table A-1 **Manual Changes by Serial Number**

Serial Prefix or Number	Make Manual Changes

Table A-2 **Manual Changes by Firmware Version**

Version	Make Manual Changes
1.00	“Change 1” on page 209, “Change 2” on page 209
1.10	“Change 2” on page 209

Agilent Technologies uses a two-part, ten-character serial number that is stamped on the serial number plate (Figure A-1). The first five characters are the serial prefix and the last five digits are the suffix.

Execute the ***IDN?** command on page 125 to check the firmware version.

Figure A-1 **Serial Number Plate (Example)**

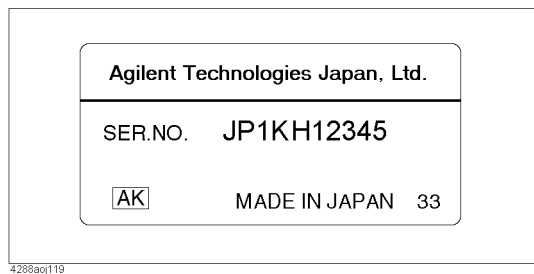

4288aag119

Change 1

The firmware revision 1.00 does not support the following function and command. Please delete their descriptions in this manual.

- External test
- **:SYST:TEST?** command on page 194

Change 2

The firmware revisions 1.00 and 1.10 do not support the following functions and commands. Please delete their descriptions in this manual.

- Displaying compensation data in the instrument setup display area
- Selecting parameter format of OPEN/SHORT compensation data
- **:CORR:CKIT:STAN1:FORM** command on page 154
- **:CORR:CKIT:STAN2:FORM** command on page 154

Manual Changes
Manual Changes

B Information for Replacing 4278A with 4288A

This appendix describes information that is applicable when replacing the Agilent 4278A with the Agilent 4288A. See the *4278A Operation Manual* for more detailed information on the 4278A. See the *4288A Operation Manual* and the other chapters of this manual (*Programming Manual*) for more detailed information on the 4288A.

Functional Comparison and GPIB Command Correspondence

This section compares the functions of the 4278A and 4288A and shows the correspondence between the instruments' usage of GPIB commands. Refer to Table B-25 on page 238 and Table B-26 on page 241 for at-a-glance lists showing the correspondences of all GPIB commands.

Reset

GPIB command correspondence

Table B-1

Correspondence of reset commands

Function	GPIB command	
	4278A	4288A
Reset	*RST	:SYST:PRES

NOTE

Although the 4278A also has a command named *RST, it corresponds to 4288A's :SYST:PRES command instead of the 4288A's *RST command.

Measurement parameters

Functional comparison

Measurement parameter		Availability (yes: O, no: X)	
Primary parameter	Secondary parameter	4278A	4288A
Cp	D	O	O
	Q	O	O
	G	O	O
	Rp	X	O
Cs	D	O	O
	Q	O	O
	Rs	O	O

Differences in usage of GPIB commands

	4278A	4288A
Parameter setup method	The primary and secondary parameters are set up simultaneously with one command.	The primary and secondary parameters are set up individually with two different commands.

GPIB command correspondence

Table B-2

Correspondence of measurement parameter setup commands

Measurement parameter		GPIB command		
Primary parameter	Secondary parameter	4278A	4288A	
Cp	D	MPAR1	:CALC1:FORM CP	:CALC2:FORM D
	Q	MPAR2		:CALC2:FORM Q
	G	MPAR3		:CALC2:FORM G
Cs	D	MPAR4	:CALC1:FORM CS	:CALC2:FORM D
	Q	MPAR5		:CALC2:FORM Q
	Rs	MPAR6		:CALC2:FORM RS

Measurement signal

Functional comparison

		4278A	4288A
Measurement frequency		1 kHz, 1 MHz	1 kHz, 1 MHz
Frequency shift (1 MHz)		+2%, +1%, 0%, -1%	+2%, +1%, 0%, -1%
Measurement signal level (OSC level)	Allowable setup range	0.1 V to 1 V	0.1 V to 1 V
	Resolution	0.1	0.01
	Level monitor	Unavailable	Current value, voltage value

GPIB command correspondence

Table B-3

Correspondence of measurement signal setup commands

Function		GPIB command (option number)	
		4278A	4288A
Measurement frequency	1 kHz	FREQ1	:SOUR:FREQ 1KHZ
	1 MHz	FREQ2	:SOUR:FREQ 1MHZ
Frequency shift*1 (1 MHz)	0%	Normal	:SYST:FSH 0
	+1%	Option 003	:SYST:FSH 1
	-1%	Option 005	:SYST:FSH -1
	+2%	Option 006	:SYST:FSH 2
Measurement signal level (OSC level)		OSC=	:SOUR:VOLT

*1. The frequency shift of the 4278A is fixed to a constant value, depending on the configuration options. No command is available to alter the value.

High-accuracy measurement (HI-ACC) mode

The 4288A does not have a function corresponding to the 4278A's high-accuracy measurement (HI-ACC) mode at the measurement frequency of 1 MHz.

Measurement range

Functional comparison

The following table shows the allowable measurement ranges for the 4278A and the 4288A.

At the measurement frequency of 1 kHz, the 4288A provides almost perfect upward compatibility with the 4278A. The measurement ranges that can be set for the 4278A, except for the 100 μF range, can also be set for the 4288A. If you select only these measurement ranges, the 4288A provides the same level of accuracy as the 4278A. However, it is recommended that you select the most appropriate measurement range for high-accuracy measurement.

At the measurement frequency of 1 MHz, the 4288A provides almost no compatibility with the 4278A, so you cannot specify the same measurement ranges except for the 1 pF range.

Measurement frequency: 1 kHz				Measurement frequency: 1 MHz			
4278A		4288A		4278A		4288A	
Range	Output resistance	Range	Output resistance	Range	Output resistance	Range	Output resistance
100 pF	100 Ω	100 pF	20 Ω	1 pF	20 Ω	1 pF	20 Ω
		220 pF	20 Ω	2 pF	20 Ω		
		470 pF	20 Ω			2.2 pF	20 Ω
1 nF	100 Ω	1 nF	20 Ω	4 pF	20 Ω	4.7 pF	20 Ω
		2.2 nF	20 Ω	8 pF	20 Ω		
		4.7 nF	20 Ω			10 pF	20 Ω
10 nF	100 Ω	10 nF	20 Ω	16 pF	20 Ω	22 pF	20 Ω
		22 nF	20 Ω				
		47 nF	20 Ω				
100 nF	20 Ω	100 nF	20 Ω	32 pF	20 Ω	47 pF	20 Ω
		220 nF	1.2 Ω	64 pF	20 Ω	100 pF	20 Ω
		470 nF	1.2 Ω	128 pF	20 Ω	220 pF	20 Ω
1 μF	1.2 Ω	1 μF	1.2 Ω	256 pF	20 Ω	470 pF	20 Ω
		2.2 μF	1.2 Ω	512 pF	20 Ω		
		4.7 μF	1.2 Ω	1024 pF	20 Ω	1 nF	20 Ω
10 μF	1.2 Ω	10 μF	1.2 Ω				
100 μF	20 Ω						

Differences in usage of GPIB commands

	4278A	4288A
Correspondence between the measurement frequency and the measurement range	Measurement range is set for both 1 kHz and 1 MHz frequencies. Different setup commands are provided for each allowable measurement range at both 1 kHz and 1 MHz frequencies.	Measurement range is set for both 1 kHz and 1 MHz frequencies. If a change in the measurement frequency conflicts with the measurement range setting, an acceptable range is automatically selected.

GPIB command correspondence

Table B-4

Correspondence of measurement range setup commands

Measurement frequency	Setup		GPIB command	
	Measurement range		4278A	4288A
	4278A	4288A		
1 kHz	Auto	Auto	RA0	:RANG:AUTO ON
	100 pF	100 pF	RA1	:RANG 100PF
	1 nF	220 pF	RA2	:RANG 220PF
		470 pF		:RANG 470PF
		1 nF		:RANG 1NF
	10 nF	2.2 nF	RA3	:RANG 2.2NF
		4.7 nF		:RANG 4.7NF
		10 nF		:RANG 10NF
	100 nF	22 nF	RA4	:RANG 22NF
		47 nF		:RANG 47NF
		100 nF		:RANG 100NF
	1 μF	220 nF	RA5	:RANG 220NF
		470 nF		:RANG 470NF
		1 μF		:RANG 1UF
10 μF	2.2 μF	RA6	:RANG 2.2UF	
	4.7 μF		:RANG 4.7UF	
	10 μF		:RANG 10UF	
100 μF	Not available	RA7	Not available	
1 MHz	Auto	Auto	RB0	:RANG:AUTO ON
	1 pF	1 pF	RB1	:RANG 1PF
	2 pF	2.2 pF	RB2	:RANG 2.2PF
	4 pF	2.2 pF	RB3	:RANG 2.2PF
		4.7 pF		:RANG 4.7PF
	8 pF	4.7 pF	RB4	:RANG 4.7PF
		10 pF		:RANG 10PF
	16 pF	10 pF	RB5	:RANG 10PF
		22 pF		:RANG 22PF
	32 pF	22 pF	RB6	:RANG 22PF
		47 pF		:RANG 47PF
	64 pF	47 pF	RB7	:RANG 47PF
		100 pF		:RANG 100PF
	128 pF	100 pF	RB8	:RANG 100PF
220 pF		:RANG 220PF		
256 pF	220 pF	RB9	:RANG 220PF	
	470 pF		:RANG 470PF	
512 pF	470 pF	RB10	:RANG 470PF	
	1 nF		:RANG 1NF	
1024 pF	1 nF	RB11	:RANG 1NF	

B. Information for Replacing 4278A with 4288A

Integration time (measurement time)/averaging

Functional comparison

		4278A	4288A
Integration time (measurement time)		SHORT, MEDIUM, LONG	SHORT ^{*1} , LONG
Averaging count	Allowable setup range	1 to 256	1 to 256
	Resolution	Only 9 points: 1,2,4,8,16,32,64,128,256	1

*1. The SHORT mode of the 4288A corresponds to both the SHORT and MEDIUM modes of the 4278A.

Differences in usage of GPIB commands

	4278A	4288A
ON/OFF of the averaging function	The averaging function cannot be turned ON/OFF. It is always ON (equivalent to OFF when the averaging count is set to 1).	The averaging function can be turned ON/OFF. You have to turn ON the averaging function when setting the averaging count.

GPIB command correspondence

Table B-5

Correspondence of measurement time/averaging/trigger delay time setup commands

Setup		GPIB command	
		4278A	4288A
Integration time (measurement time)	SHORT	ITIM1	:APER SHOR
	MEDIUM	ITIM2	
	LONG	ITIM3	:APER LONG
Averaging count		AVE=	:AVER:COUN :AVER ON

Cable length

Functional comparison

	4278A	4288A
Cable length	0 m, 1 m, 2 m	0 m, 1 m, 2 m

GPIB command correspondence

Table B-6

Correspondence of setup commands related to measurement time

Setup		GPIB command	
		4278A	4288A
Cable length	0 m	CABL0	:CAL:CABL 0
	1 m	CABL1	:CAL:CABL 1
	2 m	CABL2	:CAL:CABL 2

Trigger/delay (trigger delay) time

Functional comparison

		4278A	4288A
Trigger mode		INT, EXT, MAN	INT, EXT, BUS ^{*1} , MAN
Delay time (trigger delay time)	Allowable setup range	0.001 to 1	0.001 to 1
	Resolution	0.001	0.001

*1. For the 4278A, no discrimination needs to be made between the EXT mode and the BUS mode. On the other hand, for the 4288A, you must specify the EXT mode when supplying a trigger from an external trigger terminal or handler interface or the BUS mode when supplying a trigger through GPIB.

Differences in usage of GPIB commands

	4278A	4288A
Operation of *TRG command	Generates a trigger when the trigger mode is EXT.	Generates a trigger and reads out the measurement result after the completion of measurement when the trigger mode is BUS.

GPIB command correspondence

Table B-7

Correspondence of trigger mode/delay time setup commands

Function		GPIB command	
		4278A	4288A
Generating a trigger		*TRG	:TRIG
Generating a trigger and reading out the measurement result		Similar function is performed by executing *TRG during continuous data output (after execution of DST).	*TRG
Trigger mode	INT	TRIG1	:TRIG:SOUR INT
	EXT	TRIG2	:TRIG:SOUR EXT
	BUS		:TRIG:SOUR BUS
	MAN	TRIG3	:TRIG:SOUR MAN
Delay time (trigger delay time)		DTIM=	:TRIG:DEL

Compensation

Functional comparison

		4278A	4288A	
OPEN/SHORT/ LOAD compensation	ON/OFF	Each compensation can be turned ON/OFF separately.	Each compensation can be turned ON/OFF separately.	
	Parameter format of compensation data	OPEN	Cp-G	G-B, Cp-G
		SHORT	Ls-Rs	R-X, Ls-Rs
		LOAD	Same as the reference value for LOAD compensation.	Same as the reference value for LOAD compensation.
	Setup parameter of the reference value for LOAD compensation (definition value of the standard for the LOAD compensation)	Cp-D, Cp-G	Cp-D, Cp-Q, Cp-G, Cp-Rp, Cs-D, Cs-Q, Cs-Rs	
	Input/output of compensation data	Reading out (displaying)	Reading out (displaying) and writing (GPIB command only)	
	Alarm message output condition during compensation data measurement	OPEN	$ Y \geq 20 \mu S$	$ Y \geq 20 \mu S$
		SHORT	$ Z \geq 20 \Omega$	$ Z \geq 20 \Omega$
		LOAD	$ Z \leq Z_{ref} \times 0.9$ $ Z \geq Z_{ref} \times 1.1$	$ Z \leq Z_{ref} \times 0.9$ $ Z \geq Z_{ref} \times 1.1$
Operation after output of an alarm message during compensation data measurement	Used as it is.	Used as it is.		
Offset compensation		Can be turned ON/OFF separately for either primary or secondary parameters.	Cannot be turned ON/OFF separately for primary and secondary parameters (turned ON/OFF at the same time for all parameters).	
Temperature compensation		Available	Not necessary	

Differences in usage of GPIB commands

	4278A	4288A
ON/OFF of OPEN/SHORT/LOAD compensation	Measuring compensation data does not change ON/OFF setup.	Measuring compensation data automatically turns it ON.
Setup of the reference value for LOAD compensation	Two different commands are used to set up primary and secondary parameters separately.	A single command is used to set up primary and secondary parameters at the same time.
Setup of data for offset compensation	Two different commands are used to set up the compensation data for the primary and secondary parameters separately.	A single command is used to set up the compensation data for both the primary and secondary parameters at the same time.

GPIB command correspondence

Table B-8

Correspondence of compensation function commands

Function		GPIB command		
		4278A	4288A	
OPEN compensation	OFF	OPEN0	:CORR:OPEN OFF	
	ON	OPEN1	:CORR:OPEN ON	
SHORT compensation	OFF	SHOR0	:CORR:SHOR OFF	
	ON	SHOR1	:CORR:SHOR ON	
Standard (LOAD) compensation	OFF	STD0	:CORR:LOAD OFF	
	ON	STD1	:CORR:LOAD ON	
Offset compensation	OFF	Primary parameter	AOFF0	:CORR:OFFS OFF
		Secondary parameter	BOFF0	
	ON	Primary parameter	AOFF1	:CORR:OFFS ON
		Secondary parameter	BOFF1	
Defining the standard value for standard (LOAD) compensation	Setting the definition parameter		SPAR1	:CORR:CKIT:STAN3:FORM CPD
			SPAR2	:CORR:CKIT:STAN3:FORM CPG
	Setting the Cp value	CSTD=	:CORR:CKIT:STAN3	
	Setting the D value	DSTD=		
	Setting the G value	GSTD=		
Reading out the setup value	STR?	:CORR:CKIT:STAN3?		
Executing the measurement to obtain measured compensation value (data for compensation)	OPEN	XOP	:CORR:COLL STAN1	
	SHORT	XSH	:CORR:COLL STAN2	
	Standard (LOAD)	XSTD	:CORR:COLL STAN3	
Setup of the data for offset compensation	Primary parameter	OFFA=	:CORR:OFFS:DATA	
	Secondary parameter	OFFB=		
Reading out the measured compensation value (data for compensation)	OPEN	OPM?	:CORR:CKIT:STAN1:FORM CPG :CORR:DATA? STAN1	
	SHORT	SHM?	:CORR:CKIT:STAN2:FORM? LSRS :CORR:DATA? STAN2	
	Standard (LOAD)	STM?	:CORR:DATA? STAN3	
Executing temperature compensation		XTMP	N/A (temperature compensation not needed)	

B. Information for Replacing 4278A with 4288A

Multi-compensation

Functional comparison

	4278A	4288A
Number of channels	256 channels	64 channels
Channel selection	GPIB command, scanner interface (/CH0 to /CH7)	Front panel, GPIB command, scanner interface (/CH0 to /CH5)
Setup mode for the reference value for LOAD compensation (definition value of the standard for LOAD compensation)	Common to all channels	Common to all channels or separate for each channel

GPIB command correspondence

Table B-9

Correspondence of commands related to multi-compensation

Setup		GPIB command	
		4278A	4288A
Multi-compensation	OFF	MCOM0	:CORR:MULT OFF
	ON	MCOM1	:CORR:MULT ON
Channel selection		CN0=	:CORR:MULT:CHAN
Setup mode for the reference value for LOAD compensation (definition value of the standard for LOAD compensation)	Common to all channels	Not selectable (always common to all channels)	:CORR:MULT:CKIT:STAN3 OFF
	Separate for each channel		:CORR:MULT:CKIT:STAN3 ON

Comparator

Functional comparison

		4278A	4288A
Sorting target parameter		Cp-D, Cp-Q, Cp-G, Cs-D, Cs-Q, Cs-Rs	Cp-D, Cp-Q, Cp-G, Cp-Rp, Cs-D, Cs-Q, Cs-Rs
Reverse parameter function		Available	N/A
Limit mode (way of designating the limit range)	Using a deviation from the reference value for designation	% tolerance mode, absolute tolerance mode	% tolerance mode, absolute tolerance mode
	Using an absolute value for designation	Sequential mode	Absolute mode
BIN sorting	Primary parameter	9 BINS + OUT_OF_BINS	9 BINS + OUT_OF_BINS
	Secondary parameter	PASS/FAIL judgment	PASS/FAIL judgment
AUX BIN function		Available	Available
BIN count function		Counting all sorting results, counting for each channel	Counting all sorting results, counting for each channel
Low C reject function		Select the detection limit value from 1%, 2%, 3%, 4%, 5%, or 6%.	Set up the detection limit value freely within the range of 0 to 10%.

Differences in usage of GPIB commands

	4278A	4288A
Sorting target parameter	Can be set up independently of the measurement parameter.	Depends on the measurement parameter and cannot be set up independently.
ON/OFF of BIN	You cannot turn ON/OFF each BIN separately. Sorting targets are all of the BINs for which the limit range has been set up. Therefore, to exclude BINs that have been set up from sorting targets, you need to clear all the limit ranges and set them again.	You can turn ON/OFF each BIN separately. Sorting targets are the BINs set to ON only. Therefore, when setting up BINs, you need to set up the limit range for each BIN and then turn it ON.
Setting limit ranges in absolute values	You use a single command to set up the limit ranges for all BINs (sequential mode). The limit ranges of each BIN must be continuous.	You use several commands to set up the limit range for each BIN separately (absolute mode). The limit range of each BIN does not have to be continuous (that is, gaps are allowed).
ON/OFF of Low C reject function	Executing the limit value setup command (the boundary value to detect Low C) turns ON the Low C reject function.	Executing the limit value setup command does not turn ON the Low C reject function automatically. Therefore, you need to set up the limit value and then turn ON the Low C reject function.
Sorting result when Low C occurs	Sorts into NPP reserved only for Low C.	Sorts into suitable BIN according to measurement results. (The 4288A does not have a BIN reserved for only Low C.)
BIN count function	UNVAL: Counts into OUT_OF_BINS. Low C: No count	OVLN: Counts into OVLN. Low C: Counts into a suitable BIN according to measurement results.

Information for Replacing 4278A with 4288A
Functional Comparison and GPIB Command Correspondence

Table B-10

List of instrument's responses to UNBAL/OVLD and Low C

		Notification on the display		GPIB output		Activated handler interface signal(s)
		Measurement results	Comparator sorting results	Measurement results	Comparator sorting results	
UNBAL (OVLD)	4278A	UNBAL	OUT	2.0E20	0	/UNBAL
	4288A	OVLD	****	9.9E37	11	/OVLD
Low C	4278A	Normal operation	NPP	Normal operation	11	/PLO
	4288A	Normal operation	LOWC	Normal operation	Normal operation *1	/LOW_C_REJECT + One of sorting result signals (/BIN1-9, /OUT_OF_BINS, /AUX_BIN) + /PLO or PHI *2

*1. The measurement status (Nomal:0, OVLD:1, Low C:2) is used to detect Low C through GPIB.

*2./LOW_C_REJECT becomes active together with the signal that corresponds to the result of normal sorting judgment (judgment result when no error occurs).

GPIB command correspondence

Table B-11

Correspondence of comparator function commands

Setup		GPIB command	
		4278A	4288A
Comparator	OFF	COMP0	:CALC:COMP OFF
	ON	COMP1	:CALC:COMP ON
Limit parameter (sorting target parameter) *1	Cp-D	LPAR1	:CALC2:FORM D
	Cp-Q	LPAR2	:CALC1:FORM CP :CALC2:FORM Q
	Cp-G	LPAR3	:CALC2:FORM G
	Cs-D	LPAR4	:CALC2:FORM D
	Cs-Q	LPAR5	:CALC1:FORM CS :CALC2:FORM Q
	Cs-Rs	LPAR6	:CALC2:FORM RS
Reverse parameter function	OFF	REVP0	Not available
	ON	REVP1	
Limit mode selection	% tolerance	LMOD1	:CALC:COMP:MODE PCNT
	Absolute tolerance	LMOD2	:CALC:COMP:MODE DEV
	Sequential	LMOD3	Not available
	Absolute	Not available	:CALC:COMP:MODE ABS
Setting limit range in the tolerance mode	Nominal value (reference value)	NOM=	:CALC:COMP:PRIM:NOM
	BIN1	BIN1=	:CALC:COMP:PRIM:BIN1 :CALC:COMP:PRIM:BIN1:STAT ON
	BIN2	BIN2=	:CALC:COMP:PRIM:BIN2 :CALC:COMP:PRIM:BIN2:STAT ON
	BIN3	BIN3=	:CALC:COMP:PRIM:BIN3 :CALC:COMP:PRIM:BIN3:STAT ON

Table B-11 Correspondence of comparator function commands

Setup		GPIB command	
		4278A	4288A
Setting limit range in the tolerance mode	BIN4	BIN4=	:CALC:COMP:PRIM:BIN4 :CALC:COMP:PRIM:BIN4:STAT ON
	BIN5	BIN5=	:CALC:COMP:PRIM:BIN5 :CALC:COMP:PRIM:BIN5:STAT ON
	BIN6	BIN6=	:CALC:COMP:PRIM:BIN6 :CALC:COMP:PRIM:BIN6:STAT ON
	BIN7	BIN7=	:CALC:COMP:PRIM:BIN7 :CALC:COMP:PRIM:BIN7:STAT ON
	BIN8	BIN8=	:CALC:COMP:PRIM:BIN8 :CALC:COMP:PRIM:BIN8:STAT ON
	BIN9	BIN9=	:CALC:COMP:PRIM:BIN9 :CALC:COMP:PRIM:BIN9:STAT ON
Setting limit range in the sequential mode		BLIM=	No equivalent command is available. However, the same functionality can be obtained by setting the limit mode to the absolute mode and then setting up each BIN with the same command as in the tolerance mode.
Secondary parameter limit range		SLIM=	:CALC:COMP:SEC:LIM :CALC:COMP:SEC:STAT ON
Clearing the limit range		CLIM	:CALC:COMP:CLE
AUX BIN function	OFF	AUX0	:CALC:COMP:AUXB OFF
	ON	AUX1	:CALC:COMP:AUXB ON
Low C reject function *2	OFF	CREJ0	:CREJ OFF
	Limit 1%, ON	CREJ1	:CREJ:LIM 1 :CREJ ON
	Limit 2%, ON	CREJ2	:CREJ:LIM 2 :CREJ ON
	Limit 3%, ON	CREJ3	:CREJ:LIM 3 :CREJ ON
	Limit 4%, ON	CREJ4	:CREJ:LIM 4 :CREJ ON
	Limit 5%, ON	CREJ5	:CREJ:LIM 5 :CREJ ON
	Limit 6%, ON	CREJ6	:CREJ:LIM 6 :CREJ ON
BIN count function	OFF	CNT0	:CALC:COMP:COUN OFF
	ON	CNT1	:CALC:COMP:COUN ON
	Resetting the count value	RCNT	:CALC:COMP:COUN:CLE
	Reading out the count value	COUN?	:CALC:COMP:COUN:DATA? :CALC:COMP:COUN:OVLD?
	Reading out the count value for each channel	CCOU?	:CALC:COMP:COUN:MULT:DATA? :CALC:COMP:COUN:MULT:OVLD?

*1. For the 4288A, this setup is commonly applied to the measurement parameters. Therefore, the command to set up each measurement parameter is given here.

*2. The limit is specified as a percentage of the measurement range. Thus, for the same limit (%) value, the 4278A and the 4288A may show different boundary values where Low C is actually detected if the measurement ranges are not identical.

B. Information for Replacing 4278A with 4288A

Display

Functional comparison

The following table shows the functional comparison related to the display.

		4278A	4288A
Displayed items* ¹		Display format: Measured value display format (MEAS PAGE), Classification display format (SORT PAGE), Compensation value display format (STATUS PAGE), Limit table display format (LIMIT PAGE) Monitor line: Select from 6 values.	Display format: Only the format in which the measured value and the instrument setup indicated with the ▼ symbol are displayed Instrument setup display area: Select from 34 display pages.
ON/OFF state for displaying measured value		Unavailable	Available
Number of display digits for measured value		4, 5, or 6 digits	4, 5, or 6 digits
Method to display measured value (Selecting fixed/floating point display* ²)		Only fixed point display (display using the fixed point location, which depends on each measurement range)	Fixed point display (display using the user-designated fixed point location regardless of the measurement range), display using the floating point location (changes depending on the measured value)
Deviation display of measured value (deviation measurement mode)	Primary parameter	Percentage display of the deviation relative to the reference value (measured value - reference value) only	Deviation (measured value - reference value) display, percentage display of deviation relative to the reference value
	Secondary parameter	Unavailable	Deviation (measured value - reference value) display, percentage display of the deviation relative to the reference value

*1. For items displayed in each display format, refer to Table B-12.

*2. In the 4278A's fixed point display, the decimal point is fixed to an appropriate place for each range. This enables you to obtain an optimized display for several different measurement ranges. On the other hand, in the 4288A's fixed point display, the decimal point is fixed to a certain place regardless of the measurement range. Therefore, you need to set up a proper decimal point place (the value of the highest digit) each time you change the measurement range. As Table B-13 shows, the value of the highest digit to operate the 4288A's fixed point display is the same as that of the 4278A.

The display (LCD) of the 4288A is smaller than that of the 4278A. This prevents the 4288A from simultaneously displaying all of the items that can be displayed at one time with the 4278A, as shown in Table B-12. Since the 4278A and the 4288A employ totally different display methods, there is no compatibility of the usage related to the setup of items to be displayed.

For items that are described as “not displayed” in Table B-12 and items that are not described in Table B-12, you can check their setup status by calling the screen to set up the value for each item (performing key operation for setup). This is possible for both the 4278A and 4288A.

Table B-12

Displayed item

Displayed item		4278A *1				4288A *2	
		MEAS PAGE	LIMIT PAGE	SORT PAGE	STATUS PAGE		
Measurement result	Primary parameter	○	×	○	×	○	
	Secondary parameter	○	×	○	×	○	
Measurement condition	Measurement signal	Frequency	○	×	○	○	1
		Level	○	×	○	○	1
	Integration time (measurement time)	○	×	○	○	▼	
	Averaging count	○	×	○	○	2	
	Cable length	○	×	○	○	2	
	Measurement range	○	×	○	○	3	
	Trigger delay time	○	×	○	○	3	
	Trigger mode	○	×	○	○	▼	
	Channel number for the multi compensation	○	×	○	○	5	
OPEN compensation	ON/OFF state	×	×	×	○	▼	
	Measured value (compensation data)	M	M	M	○	25 to 26	
SHORT compensation	ON/OFF state	×	×	×	○	▼	
	Measured value (compensation data)	M	M	M	○	27 to 28	
Standard (LOAD) compensation	ON/OFF state	×	×	×	○	▼	
	Measured value (compensation data)	M	M	M	○	29 to 30	
	Reference value (standard definition value)	M	M	M	○	31 to 32	
Offset compensation	ON/OFF state	×	×	×	○	▼	
	Compensation data	M	M	M	○	33 to 34	
Comparator	ON/OFF state	○	×	○	○	▼	
	Sorting judgment result	×	×	○	×	6	
	Primary parameter limit range	limit range	×	○	×	×	7 to 15
		Nominal value (reference value)	M	○	M	M	17
	Secondary parameter limit range	×	○	×	×	16	
	ON/OFF state of AUX BIN	×	○	×	×	18	
	BIN count value	×	○	×	×	19 to 24	
	Low C reject function	ON/OFF state	×	×	×	×	▼
Limit		×	×	×	×	×	
Measurement signal level monitor result		No measurement signal level monitor function.				4	

*1. ○: Items always displayed, ×: Items not displayed

M: Items displayed in the monitor line (you can select only 1 item)

*2. ○: Items always displayed, ×: Items not displayed

▼: Items whose setup state is displayed with the ▼ symbol at the bottom of the display

1 to 34: Items displayed on page 1 to 34 of the instrument setup display area

(multiple pages cannot be displayed at the same time.)

Information for Replacing 4278A with 4288A
Functional Comparison and GPIB Command Correspondence

Table B-13

Msd settings needed to make the 4288A's fixed point display equivalent to that of the 4278A

Measurement signal frequency	Measurement range	Primary parameter	Secondary parameter*1	
		Cp, Cs	G	Rs
1 kHz	100 pF	100 pF	1 μ S	1 M Ω
	220 pF			
	470 pF			
	1 nF	1 nF		100 k Ω
	2.2 nF			
	4.7 nF			
	10 nF	10 nF	10 μ S	10 k Ω
	22 nF			
	47 nF			
	100 nF	100 nF	1 mS	1 k Ω
	220 nF			
	470 nF			
	1 μ F	1 μ F		100 Ω
	2.2 μ F			
	4.7 μ F			
10 μ F	10 μ F	10 mS	10 Ω	
1 MHz	1 pF	1 pF	1 μ S	100 k Ω
	2.2 pF		10 μ S	
	4.7 pF			
	10 pF	10 pF		100 μ S
	22 pF			
	47 pF			
	100 pF	100 pF	1 mS	1 k Ω
	220 pF			
	470 pF			
	1 nF	1 nF		100 Ω

*1. The value of the highest digit of D, Q is fixed at the same value as that of the 4278A.

Differences in usage of GPIB commands

	4278A	4288A
Reference value for deviation display	You cannot set an independent reference value for deviation display. The reference value (nominal value) in the comparator tolerance mode is applied.	You can set an independent reference value for deviation display.

GPIB command correspondence

Table B-14

Correspondence of setup commands related to screen display

Setup		GPIB command	
		4278A	4288A
Display format	Measured value display format (MEAS PAGE)	DPAG1	There is no corresponding command. Refer to Table B-12 and use the following command to set up the displayed page of the instrument setup display area so that the closest state is realized. :DISP:TEXT2:PAGE
	Limit table display format (LIMIT PAGE)	DPAG2	
	Classification display format (SORT PAGE)	DPAG3	
	Compensation value display format (STATUS PAGE)	DPAG4	
Displayed item on the monitor display	Monitor display OFF	VMON0	
	Data for OPEN compensation	VMON1	
	Data for SHORT compensation	VMON2	
	Data for LOAD compensation	VMON3	
	Reference value for LOAD compensation (definition value of the standard for LOAD compensation)	VMON4	
	Data for offset compensation	VMON5	
Number of display digits for the measurement result	4	DDIG4	:DISP:TEXT1:DIG 4
	5	DDIG5	:DISP:TEXT1:DIG 5
	6	DDIG6	:DISP:TEXT1:DIG 6
Display mode	MEAS display mode (normal display)	DVAL1	:CALC1:MATH:STAT OFF
	TOL display mode (percentage display of deviation *1)	DVAL2	:CALC1:MATH:STAT ON :CALC1:MATH:EXPR:NAME PCNT

*1. For the 4278A, use the NOM= command to set the reference value. For the 4288A, use the **:DATA {REF1|REF2}** command to set the reference value.

Reading out the measurement result

Functional comparison

	4278A	4288A
Data output (data transfer) format	ASCII format, binary (64-bit) format	ASCII format, binary (64-bit) format
Measured data that can be outputted (read out)	Measured primary/secondary parameter values, comparator sorting result, BIN count value	Measurement status, measured primary/secondary parameter values, comparator sorting result, BIN count value, measurement signal level monitor value
Size of the block data transfer (data buffer)	For 500 measurements (only with scanner interface)	For 1000 measurements (Data buffer 3)
Continuous data output (spew-out mode)	Available	Unavailable
Reading out the instrument setup state list (*LRN?)	Available	Unavailable (The query is available for all the setup commands. Therefore, use each command for reading out.)

The 4288A does not provide a continuous data output function (spew-out mode). However, by executing measurement (executing the **:READ?** command and then supplying a trigger), you can read out the measurement result upon completion of measurement.

Differences in usage of GPIB commands

	4278A	4288A
Read-out data	The measured primary parameter value, measured secondary parameter value, and comparator sorting result are read out in this order. You can select whether to read out the comparator sorting result.	The measurement status, measured primary parameter value, measured secondary parameter value, and comparator sorting result are read out in this order. You cannot select whether to read out the comparator sorting result, which depends on the ON/OFF state of the comparator function.
Block data transfer (data buffer)	ON/OFF: Setting the multi-compensation function to ON starts memorizing the measurement result into the internal memory. Read-out data: Data sets of 2 (3) items consisting of the measured primary parameter value and measured secondary parameter value (and comparator sorting result) are read out for the number of measurements (up to 500) that have been stored at the execution of the command. (You can select whether to read out the comparator sorting result.)	ON/OFF: Regardless of the ON/OFF state of the multi-compensation function, making a setup to memorize data into the data buffer (internal memory) automatically starts the process of memorizing the measurement result. Read-out data: Data sets of 3 (4) items consisting of the measurement status, measured primary parameter value, and secondary parameter value (and comparator sorting result) are read out for the specified number of measurements (up to 1000). (The comparator sorting result is read out when the comparator function is set to ON.)
Binary format	Header is 4 bytes (fixed). See Figure B-1.	Header is (2 + α) bytes (not fixed). See Figure B-1.

Figure B-1

Comparison of binary format

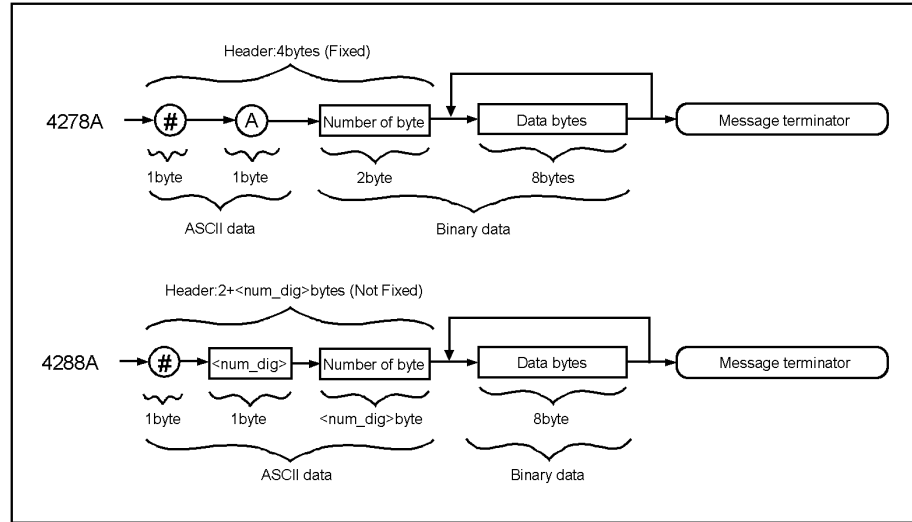

B. Information for Replacing
4278A with 4288A

GPIB command correspondence

Table B-15

Correspondence of measurement data readout related commands

Function		GPIB command	
		4278A	4288A
Data output (data transfer) format	ASCII	DFMT1	:FORM ASC
	Binary	DFMT2	:FORM REAL
Reading out the measurement result		DATA?	:FETC?
Block data transfer (data buffer)	Preparation	MCOM1	:DATA:POIN BUF3,500 :DATA:FEED:CONT BUF3,ALW
	Readout	DATA?	:DATA? BUF3
Comparator sorting result output	OFF	DBIN0	N/A (dependent on ON/OFF state of the comparator function)
	ON	DBIN1	
Continuous data output (spew-out mode)	Start	DST	N/A (Similar function can be realized using :READ?.)
	End	DEND	
Reading out the instrument setup state list		*LRN?	N/A (The query is available for all setup commands. Therefore, use each command for reading out.)

Save/recall and resume

Functional comparison

		4278A	4288A
Save/recall	Capacity	One setup	Ten setups
	Storage media	Memory card	Built-in EEPROM
	Auto recall	Contents of the memory card is automatically recalled at power-on.	N/A (Resume function is used instead)
Resume		N/A	72-hour storage

GPIB command correspondence

Table B-16

Correspondence of save/recall commands

Setup	GPIB command	
	4278A	4288A
Storing measurement condition (save)	STOR	*SAV
Loading measurement condition (recall)	LOAD	*RCL

Status registers (status report system)

Functional comparison

	4278A	4288A
Configuration	Status byte register only	Status byte register Standard event status register Operation status register Questionable status register

Information for Replacing 4278A with 4288A
Functional Comparison and GPIB Command Correspondence

The following table shows the relationship between each bit of the status byte register of the 4278A and the corresponding bit of the 4288A's register.

4278A (Status byte register)		4288A	
Bit number	Status information	Register name	Bit number
0	End of measurement	Operation status register	4
1	End of analog measurement	Operation status register	3
2	Trigger ignored	Standard event status register	3*1
3	End status	Operation status register	7
	• End of compensation data measurement		
4	• End of self-test	Operation status register	12
	Reserved		
5	Occurrence of error	Standard event status register	2 to 5
6	Service request	Status byte register	6
7	Reserved	—————	—

*1. This bit shows the occurrence of device dependent errors. "Trigger ignored" is one of the device dependent errors.

Differences in usage of GPIB commands

	4278A	4288A
Usage of the *SRE command	No space is required between the command and parameters. For example, to mask bit 0, use the command as "**SRE1".	A space is required between the command and parameters. For example, to mask bit 0, use the command as "**SRE 1".

GPIB command correspondence

Table B-17

Correspondence of status register related commands

Setup		GPIB command	
		4278A	4288A
Clear		*CLS	*CLS
Status byte register	Mask (setting the service request enable register)	*SRE	*SRE
	Reading out the register	*STB?	*STB?
Standard event status register	Setting the enable register	N/A	*ESR?
	Reading out the register		*ESE
Operation status register	Setting the enable register		:STAT:OPER:ENAB
	Reading out the register		:STAT:OPER?

B. Information for Replacing 4278A with 4288A

Example of Replacing Major Functions (comparison of programs)

Comparator

Sequential mode (absolute mode)

Table B-18 compares the programs used by the 4278A and 4288A to set the limit ranges. These ranges are the Cp limit range as shown in the following figure and the D limit range from 0 to 0.1 in the sequential mode (absolute mode).

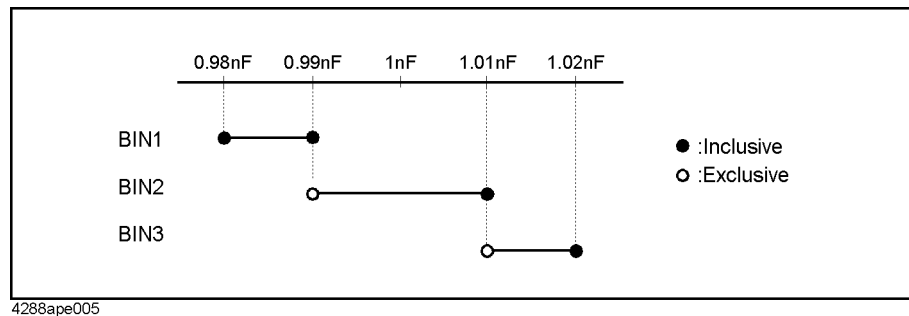

Table B-18 Comparison of programs used to set limit ranges in sequential mode

4278A	4288A
10 ASSIGN @Agt4278a TO 717	10 ASSIGN @Agt4288a TO 717
20 !	20 !
30 OUTPUT @Agt4278a;"MPAR1"	30 OUTPUT @Agt4288a;" :CALC1:FORM CP"
40 OUTPUT @Agt4278a;"LPAR1"	40 OUTPUT @Agt4288a;" :CALC2:FORM D"
50 !	50 !
60 OUTPUT @Agt4278a;"CLIM"	60 !
70 OUTPUT @Agt4278a;"LMOD3"	70 OUTPUT @Agt4288a;" :CALC:COMP:MODE ABS"
80 OUTPUT @Agt4278a;"BLIM=0.98E-9,0.99E-9,1.01E-9,1.02E-9"	80 OUTPUT @Agt4288a;" :CALC:COMP:PRIM:BIN1 0.98E-9,0.99E-9"
90 !	90 OUTPUT @Agt4288a;" :CALC:COMP:PRIM:BIN1:STAT ON"
100 !	100 OUTPUT @Agt4288a;" :CALC:COMP:PRIM:BIN2 0.99E-9,1.01E-9"
110 !	110 OUTPUT @Agt4288a;" :CALC:COMP:PRIM:BIN2:STAT ON"
120 !	120 OUTPUT @Agt4288a;" :CALC:COMP:PRIM:BIN3 1.01E-9,1.02E-9"
130 !	130 OUTPUT @Agt4288a;" :CALC:COMP:PRIM:BIN3:STAT ON"
140 !	140 FOR I=4 TO 9
150 !	150 OUTPUT @Agt4288a;" :CALC:COMP:PRIM:BIN"&VAL\$(I)&" :STAT OFF"
160 !	160 NEXT I
170 OUTPUT @Agt4278a;"SLIM=0,0.1"	170 OUTPUT @Agt4288a;" :CALC:COMP:SEC:LIM 0,0.1"
180 !	180 OUTPUT @Agt4288a;" :CALC:COMP:SEC:STAT ON"
190 !	190 !
200 END	200 END

Tolerance mode

Table B-19 compares the programs used by the 4278A and 4288A to set the limit ranges. These ranges are the Cp limit range as shown in the following figure and the D limit range from 0 to 0.1 in the tolerance mode.

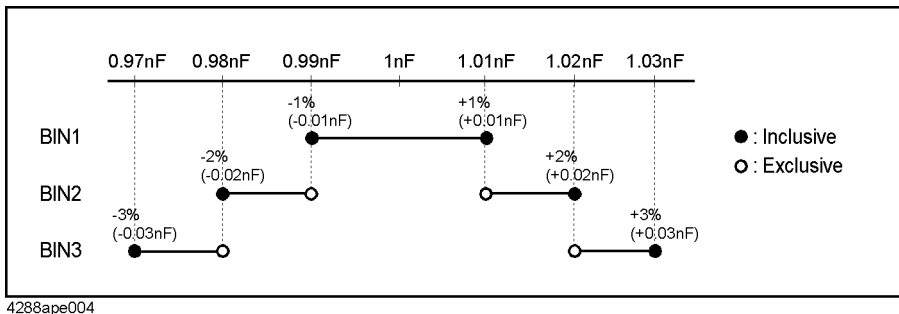

Table B-19 Comparison of programs used to set limit ranges in tolerance mode

4278A	4288A
<p>For the % tolerance mode:</p> <pre> 10 ASSIGN @Agt4278a TO 717 20 ! 30 OUTPUT @Agt4278a; "MPAR1" 40 OUTPUT @Agt4278a; "LPAR1" 50 ! 60 OUTPUT @Agt4278a; "CLIM" 70 OUTPUT @Agt4278a; "LMOD1" 80 OUTPUT @Agt4278a; "NOM=1.0E-9" 90 OUTPUT @Agt4278a; "BIN1=-1,1" 100 ! 110 OUTPUT @Agt4278a; "BIN2=-2,2" 120 ! 130 OUTPUT @Agt4278a; "BIN3=-3,3" 140 ! 150 ! 160 ! 170 ! 180 OUTPUT @Agt4278a; "SLIM=0,0.1" 190 ! 200 ! 210 END </pre>	<p>For the % tolerance mode:</p> <pre> 10 ASSIGN @Agt4288a TO 717 20 ! 30 OUTPUT @Agt4288a; ":CALC1:FORM CP" 40 OUTPUT @Agt4288a; ":CALC2:FORM D" 50 ! 60 ! 70 OUTPUT @Agt4288a; ":CALC:COMP:MODE PCNT" 80 OUTPUT @Agt4288a; ":CALC:COMP:PRIM:NOM 1.0E-9" 90 OUTPUT @Agt4288a; ":CALC:COMP:PRIM:BIN1 -1,1" 100 OUTPUT @Agt4288a; ":CALC:COMP:PRIM:BIN1:STAT ON" 110 OUTPUT @Agt4288a; ":CALC:COMP:PRIM:BIN2 -2,2" 120 OUTPUT @Agt4288a; ":CALC:COMP:PRIM:BIN2:STAT ON" 130 OUTPUT @Agt4288a; ":CALC:COMP:PRIM:BIN3 -3,3" 140 OUTPUT @Agt4288a; ":CALC:COMP:PRIM:BIN3:STAT ON" 150 FOR I=4 TO 9 160 OUTPUT @Agt4288a; ":CALC:COMP:PRIM:BIN"&VAL\$(I)&":STAT OFF" 170 NEXT I 180 OUTPUT @Agt4288a; ":CALC:COMP:SEC 0,0.1" 190 OUTPUT @Agt4288a; ":CALC:COMP:SEC:STAT ON" 200 ! 210 END </pre>
<p>For the absolute tolerance mode:</p> <pre> 10 ASSIGN @Agt4278a TO 717 20 ! 30 OUTPUT @Agt4278a; "MPAR1" 40 OUTPUT @Agt4278a; "LPAR1" 50 ! 60 OUTPUT @Agt4278a; "CLIM" 70 OUTPUT @Agt4278a; "LMOD2" 80 OUTPUT @Agt4278a; "NOM=1.0E-9" 90 OUTPUT @Agt4278a; "BIN1=-1.0E-11,1.0E-11" 100 ! 110 OUTPUT @Agt4278a; "BIN2=-2.0E-11,2.0E-11" 120 ! 130 OUTPUT @Agt4278a; "BIN3=-3.0E-11,3.0E-11" 140 ! 150 ! 160 ! 170 ! 180 OUTPUT @Agt4278a; "SLIM=0,0.1" 190 ! 200 ! 210 END </pre>	<p>For the absolute tolerance mode:</p> <pre> 10 ASSIGN @Agt4288a TO 717 20 ! 30 OUTPUT @Agt4288a; ":CALC1:FORM CP" 40 OUTPUT @Agt4288a; ":CALC2:FORM D" 50 ! 60 ! 70 OUTPUT @Agt4288a; ":CALC:COMP:MODE DEV" 80 OUTPUT @Agt4288a; ":CALC:COMP:PRIM:NOM 1.0E-9" 90 OUTPUT @Agt4288a; ":CALC:COMP:PRIM:BIN1 -1.0E-11,1.0E-11" 100 OUTPUT @Agt4288a; ":CALC:COMP:PRIM:BIN1:STAT ON" 110 OUTPUT @Agt4288a; ":CALC:COMP:PRIM:BIN2 -2.0E-11,2.0E-11" 120 OUTPUT @Agt4288a; ":CALC:COMP:PRIM:BIN2:STAT ON" 130 OUTPUT @Agt4288a; ":CALC:COMP:PRIM:BIN3 -3.0E-11,3.0E-11" 140 OUTPUT @Agt4288a; ":CALC:COMP:PRIM:BIN3:STAT ON" 150 FOR I=4 TO 9 160 OUTPUT @Agt4288a; ":CALC:COMP:PRIM:BIN"&VAL\$(I)&":STAT OFF" 170 NEXT I 180 OUTPUT @Agt4288a; ":CALC:COMP:SEC 0,0.1" 190 OUTPUT @Agt4288a; ":CALC:COMP:SEC:STAT ON" 200 ! 210 END </pre>

B. Information for Replacing 4278A with 4288A

Reading out the measurement result

Continuous data output (spew-out mode)

The 4288A does not provide a continuous data output function (spew-out mode). However, as shown in the following figure, by executing the **:READ?** command and then supplying a trigger when executing measurement, you can read out a measurement result after completion of measurement that is similar to the as-is data output of the 4278A.

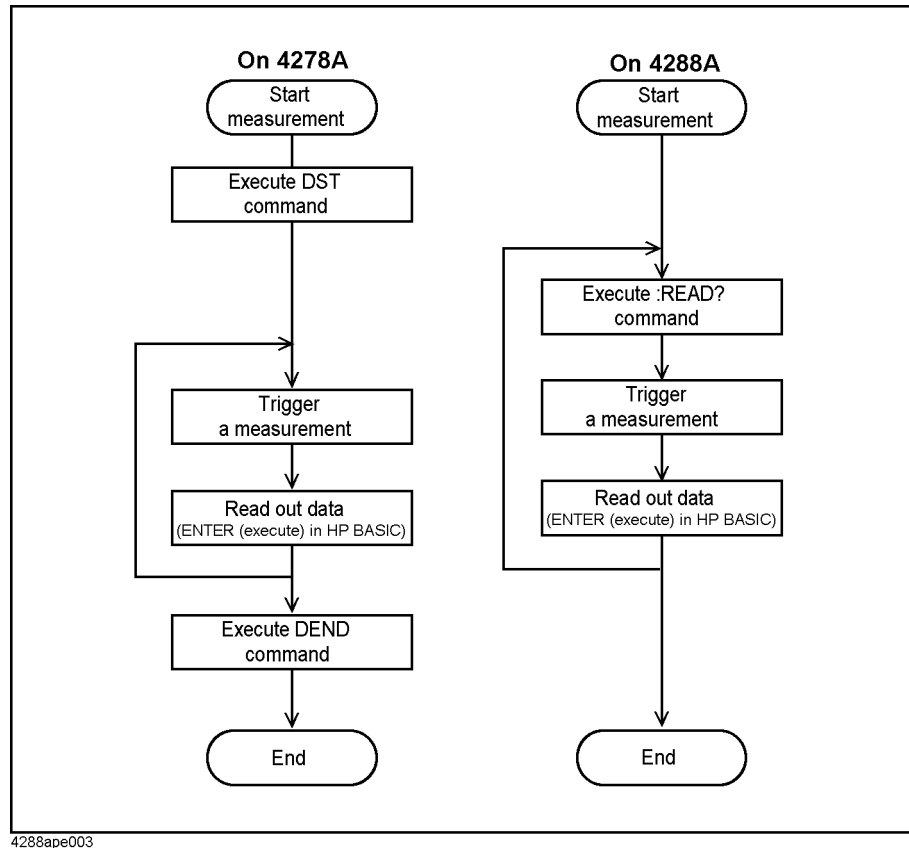

4288ape003

Table B-20 Comparison of programs used to read out measurement results

4278A	4288A
10 REAL Pri (1:5),Sec (1:5)	10 REAL Pri (1:5),Sec (1:5)
20 ASSIGN @Agt4278a TO 717	20 ASSIGN @Agt4288a TO 717
30 OUTPUT @Agt4278a;"DBIN0"	30 OUTPUT @Agt4288a;" :CALC:COMP OFF"
40 !	40 !
50 !	50 OUTPUT @Agt4288a;" :ABOR"
60 OUTPUT @Agt4278a;"TRIG2"	60 OUTPUT @Agt4288a;" :TRIG:SOUR EXT"
70 OUTPUT @Agt4278a;"DST"	70 !
80 FOR I=1 TO 5	80 FOR I=1 TO 5
90 !	90 OUTPUT @Agt4288a;" :READ?"
100 PRINT "Wait for External Trigger!!"	100 PRINT "Wait for External Trigger!!"
110 ENTER @Agt4278a;Pri (I),Sec (I)	110 ENTER @Agt4288a;Dummy,Pri (I),Sec (I)
120 NEXT I	120 NEXT I
130 OUTPUT @Agt4278a;"DEND"	130 !
140 !	140 !
150 PRINT " Pri " " Sec "	150 PRINT " Pri " " Sec "
160 FOR I=1 TO 5	160 FOR I=1 TO 5
170 PRINT Pri (I),Sec (I)	170 PRINT Pri (I),Sec (I)
180 NEXT I	180 NEXT I
190 !	190 !
200 END	200 END

Information for Replacing 4278A with 4288A
Example of Replacing Major Functions (comparison of programs)

Reading out the results for any measurement (Data buffer function)

Table B-21 compares the programs used by the 4278A and 4288A to read out the results of 100 measurements.

Table B-21 Comparison of programs used to read out results of 100 measurements

4278A	4288A
10 DIM Buff\$[9],Img\$[50]	10 DIM Buff\$[9],Dig\$[1],Read_form\$[9],Num_of_byte\$[9],Img\$[50]
20 REAL Data(1:100,1:3)	20 REAL Data(1:100,1:4)
30 ASSIGN @Binary TO 717;FORMAT OFF	30 ASSIGN @Binary TO 717;FORMAT OFF
40 ASSIGN @Agt4278a TO 717	40 ASSIGN @Agt4288a TO 717
50 !	50 !
60 OUTPUT @Agt4278a;"TRIG"	60 OUTPUT @Agt4288a;":TRIG:SOUR EXT"
70 !	70 !
80 OUTPUT @Agt4278a;"MCOM1"	80 OUTPUT @Agt4288a;":DATA:POIN BUF3,100"
90 !	90 OUTPUT @Agt4288a;":DATA:FEED:CONT BUF3,ALW"
100 OUTPUT @Agt4278a;"DBIN1"	100 OUTPUT @Agt4288a;":CALC:COMP ON"
110 OUTPUT @Agt4278a;"DFMT2"	110 OUTPUT @Agt4288a;":FORM REAL"
120 !	120 !
130 ! Triggering	130 ! Triggering
140 !	140 !
150 FOR I=1 TO 100	150 FOR I=1 TO 100
160 OUTPUT @Agt4278a;"*TRG"	160 OUTPUT @Agt4288a;":TRIG"
170 WAIT .02	170 WAIT .02
180 NEXT I	180 NEXT I
190 !	190 !
200 ! Data reading	200 ! Data reading
210 !	210 !
220 OUTPUT @Agt4278a;"DATA?"	220 OUTPUT @Agt4288a;":DATA? BUF3"
230 ENTER @Agt4278a USING "#,4A";Buff\$	230 ENTER @Agt4288a USING "#,A";Buff\$
240 !	240 ENTER @Agt4288a USING "#,A";Dig\$
250 !	250 Read_form\$="#,&Dig\$&"A"
260 !	260 ENTER @Agt4288a USING Read_form\$;Num_of_byte\$
270 ENTER @Binary;Data(*)	270 ENTER @Binary;Data(*)
280 ENTER @Agt4278a USING "#,A";Buff\$	280 ENTER @Agt4288a USING "#,A";Buff\$
290 !	290 !
300 ! Display results	300 ! Display results
310 !	310 !
320 CLEAR SCREEN	320 CLEAR SCREEN
330 Img\$="4D,3X,MD.4DE,2X,MD.4DE,2X,2D"	330 Img\$="4D,3X,D,4X,MD.4DE,2X,MD.4DE,2X,2D"
340 PRINT "[MEASUREMENT and BIN SORT RESULT]"	340 PRINT "[MEASUREMENT and BIN SORT RESULT]"
350 PRINT " Pri Sec BIN"	350 PRINT " Status Pri Sec BIN"
360 PRINT "-----"	360 PRINT "-----"
370 FOR I=1 TO 100	370 FOR I=1 TO 100
380 PRINT USING Img\$;I,Data(I,1),Data(I,2),Data(I,3)	380 PRINT USING Img\$;I,Data(I,1),Data(I,2),Data(I,3),Data(I,4)
390 NEXT I	390 NEXT I
400 END	400 END

B. Information for Replacing 4278A with 4288A

Information for Replacing 4278A with 4288A
Example of Replacing Major Functions (comparison of programs)

Compensation

Table B-22 compares the programs used by the 4278A and 4288A to perform Open/Short/Standard (Load) compensation.

Table B-22 Comparison of programs used to perform Open/Short/Standard (Load) compensation

4278A	4288A
10 DIM Buff\$[9],Inp_char\$[9]	10 DIM Buff\$[9],Inp_char\$[9]
20 REAL Data1,Data2	20 REAL Data1,Data2
30 ASSIGN @Agt4278a TO 717	30 ASSIGN @Agt4288a TO 717
40 !	40 !
50 !	50 OUTPUT @Agt4288a;":STAT:OPER:ENAB 128"
60 OUTPUT @Agt4278a;"*SRE8"	60 OUTPUT @Agt4288a;"*SRE 128"
70 !	70 !
80 OUTPUT @Agt4278a;"*CLS"	80 OUTPUT @Agt4288a;"*CLS"
90 WAIT .1	90 OUTPUT @Agt4288a;"*OPC?"
100 !	100 ENTER @Agt4288a;Buff\$
110 ON INTR 7 GOTO Open_end	110 ON INTR 7 GOTO Open_end
120 ENABLE INTR 7;2	120 ENABLE INTR 7;2
130 PRINT "[Open mesurement]"	130 PRINT "[Open mesurement]"
140 INPUT "Push [Enter] key to start",Inp_char\$	140 INPUT "Push [Enter] key to start",Inp_char\$
150 OUTPUT @Agt4278a;"XOP"	150 OUTPUT @Agt4288a;":CORR:COLL STAN1"
160 Open_wait:GOTO Open_wait	160 Open_wait:GOTO Open_wait
170 Open_end:OFF INTR 7	170 Open_end:OFF INTR 7
180 OUTPUT @Agt4278a;"OPEN1" ! Open On	180 !
190 OUTPUT @Agt4278a;"OPM?"	190 OUTPUT @Agt4288a;":CORR:DATA? STAN1"
200 ENTER @Agt4278a;Data1,Data2	200 ENTER @Agt4288a;Data1,Data2
210 PRINT " Open Compensation Data:"	210 PRINT " Open Compensation Data:"
220 PRINT " Cp:";Data1,"G:";Data2	220 PRINT " G:";Data1,"B:";Data2
230 !	230 !
240 OUTPUT @Agt4278a;"*CLS"	240 OUTPUT @Agt4288a;"*CLS"
250 WAIT .1	250 OUTPUT @Agt4288a;"*OPC?"
260 !	260 ENTER @Agt4288a;Buff\$
270 ON INTR 7 GOTO Short_end	270 ON INTR 7 GOTO Short_end
280 ENABLE INTR 7;2	280 ENABLE INTR 7;2
290 PRINT "[Short mesurement]"	290 PRINT "[Short mesurement]"
300 INPUT "Push [Enter] key to start",Inp_char\$	300 INPUT "Push [Enter] key to start",Inp_char\$
310 OUTPUT @Agt4278a;"XSH"	310 OUTPUT @Agt4288a;":CORR:COLL STAN2"
320 Short_wait: GOTO Short_wait	320 Short_wait: GOTO Short_wait
330 Short_end: OFF INTR 7	330 Short_end: OFF INTR 7
340 OUTPUT @Agt4278a;"SHOR1" ! Short On	340 !
350 OUTPUT @Agt4278a;"SHM?"	350 OUTPUT @Agt4288a;":CORR:DATA? STAN2"
360 ENTER @Agt4278a;Data1,Data2	360 ENTER @Agt4288a;Data1,Data2
370 PRINT " Short Compensation Data:"	370 PRINT " Short Compensation Data:"
380 PRINT " Ls:";Data1,"Rs:";Data2	380 PRINT " R:";Data1,"X:";Data2
390 !	390 !
400 ! Load standard definition	400 ! Load standard definition
410 OUTPUT @Agt4278a;"SPAR1"	410 OUTPUT @Agt4288a;":CORR:CKIT:STAN3:FORM CPD"
420 OUTPUT @Agt4278a;"CSTD=47E-12"	420 OUTPUT @Agt4288a;":CORR:CKIT:STAN3 47E-12,0"
430 OUTPUT @Agt4278a;"DSTD=0"	430 !
440 OUTPUT @Agt4278a;"*CLS"	440 OUTPUT @Agt4288a;"*CLS"
450 WAIT .1	450 OUTPUT @Agt4288a;"*OPC?"
460 !	460 ENTER @Agt4288a;Buff\$
470 ON INTR 7 GOTO Load_end	470 ON INTR 7 GOTO Load_end
480 ENABLE INTR 7;2	480 ENABLE INTR 7;2
490 PRINT "[Load mesurement]"	490 PRINT "[Load mesurement]"
500 INPUT "Push [Enter] key to start",Inp_char\$	500 INPUT "Push [Enter] key to start",Inp_char\$
510 OUTPUT @Agt4278a;"XSTD"	510 OUTPUT @Agt4288a;":CORR:COLL STAN3"
520 Load_wait: GOTO Load_wait	520 Load_wait: GOTO Load_wait
530 Load_end: OFF INTR 7	530 Load_end: OFF INTR 7
540 OUTPUT @Agt4278a;"STD1" ! Standard On	540 !
550 OUTPUT @Agt4278a;"STM?"	550 OUTPUT @Agt4288a;":CORR:DATA? STAN3"
560 ENTER @Agt4278a;Data1,Data2	560 ENTER @Agt4288a;Data1,Data2
570 PRINT " Load Compensation Data:"	570 PRINT " Load Compensation Data:"
580 PRINT " Cp:";Data1,"D:";Data2	580 PRINT " Cp:";Data1,"D:";Data2
590 !	590 !
600 END	600 END

Status register (status report system)

Table B-23 compares the programs used by the 4278A and 4288A to detect the completion of measurement.

Table B-23 Comparison of programs used to detect completion of measurement

4278A	4288A
10 ASSIGN @Agt4278a TO 717	10 ASSIGN @Agt4288a TO 717
20 !	20 !
30 OUTPUT @Agt4278a;"TRIG2"	30 OUTPUT @Agt4288a;"TRIG:SOUR EXT"
40 !	40 !
50 !	50 OUTPUT @Agt4288a;"STAT:OPER:ENAB 16"
60 OUTPUT @Agt4278a;"*SRE1"	60 OUTPUT @Agt4288a;"*SRE 128"
70 OUTPUT @Agt4278a;"*CLS"	70 OUTPUT @Agt4288a;"*CLS"
80 WAIT .1	80 OUTPUT @Agt4288a;"*OPC?"
90 !	90 ENTER @Agt4288a;Buff\$
100 !	100 !
110 ON INIR Scode GOTO Meas_end	110 ON INIR Scode GOTO Meas_end
120 ENABLE INIR Scode;2	120 ENABLE INIR Scode;2
130 PRINT "Wait for External Trigger!!"	130 PRINT "Wait for External Trigger!!"
140 Meas_wait: GOTO Meas_wait	140 Meas_wait: GOTO Meas_wait
150 Meas_end: OFF INIR Scode	150 Meas_end: OFF INIR Scode
160 PRINT "Measurement Complete"	160 PRINT "Measurement Complete"
170 !	170 !
180 END	180 END

B. Information for Replacing 4278A with 4288A

Table B-24 compares the programs used by the 4278A and 4288A to detect the occurrence of an error.

Table B-24 Comparison of programs used to detect occurrence of errors

4278A	4288A
10 ASSIGN @Agt4278a TO 717	10 ASSIGN @Agt4288a TO 717
20 !	20 !
30 !	30 OUTPUT @Agt4288a;"*ESE 60"
40 OUTPUT @Agt4278a;"*SRE32"	40 OUTPUT @Agt4288a;"*SRE 32"
50 OUTPUT @Agt4278a;"*CLS"	50 OUTPUT @Agt4288a;"*CLS"
60 WAIT .1	60 OUTPUT @Agt4288a;"*OPC?"
70 !	70 ENTER @Agt4288a;Buff\$
80 !	80 !
90 ON INIR 7 GOTO Err_proc	90 ON INIR 7 GOTO Err_proc
100 ENABLE INIR 7;2	100 ENABLE INIR 7;2
110 !	110 !
120 OUTPUT @Agt4278a;"XYZ" ! Error	120 OUTPUT @Agt4288a;"XYZ" ! Error
130 !	130 !
140 GOTO Skip_err_proc	140 GOTO Skip_err_proc
150 Err_proc: OFF INIR 7	150 Err_proc: OFF INIR 7
160 OUTPUT @Agt4278a;"ERR?"	160 OUTPUT @Agt4288a;"::SYST:ERR?"
170 ENTER @Agt4278a;Err_no	170 ENTER @Agt4288a;Err_no,Err_mes\$
180 PRINT "Error occurred!!"	180 PRINT "Error occurred!!"
190 PRINT " No: ";Err_no	190 PRINT " No: ";Err_no,"Description: "&Err_mes\$
200 PRINT "PROGRAM INTERRUPT!!"	200 PRINT "PROGRAM INTERRUPT!!"
210 GOTO Prog_end	210 GOTO Prog_end
220 Skip_err_proc: PRINT "PROGRAM DONE."	220 Skip_err_proc: PRINT "PROGRAM DONE."
230 Prog_end: END	230 Prog_end: END

At-a-Glance List of GPIB Command Correspondence

Table B-25 (alphabetical order of 4278A commands) and Table B-26 (by function of 4278A commands) provide at-a-glance lists of the GPIB command correspondence between the 4278A and the 4288A. For details on the command correspondence, refer to “Functional Comparison and GPIB Command Correspondence” on page 212.

Table B-25 At-a-glance list of GPIB command correspondence between 4278A and 4288A (alphabetical order)

4278A	Function overview	4288A
[A]		
AOFF{0 1}	Turns ON/OFF the offset compensation for the primary parameter.	:CORR:OFFS on page 163
AUX{0 1}	Turns ON/OFF the AUX BIN function.	:CALC:COMP:AUXB on page 135
AVE=	Sets the averaging count.	:AVER:COUN on page 132
[B]		
BIN{1-9}=	Sets the limit range of each BIN in the tolerance mode.	:CALC:COMP:PRIM:BIN{1-9} on page 142
BLIM=	Sets the limit range in the sequential mode.	
BOFF{0 1}	Turns ON/OFF the offset compensation for the secondary parameter.	:CORR:OFFS on page 163
[C]		
CABL{0-2}	Sets the cable length.	:CAL:CABL on page 133
CCOU?	Reads out the BIN count value of each channel.	:CALC:COMP:COUN:MULT:DATA? on page 139 :CALC:COMP:COUN:MULT:OVLD? on page 140
CLIM	Clears all limit ranges.	:CALC:COMP:CLE on page 136
CNO=	Sets the channels for multi-compensation.	:CORR:MULT:CHAN on page 161
CNT{0 1}	Turns ON/OFF the BIN count function.	:CALC:COMP:COUN on page 137
COMP{0 1}	Turns ON/OFF the comparator function.	:CALC:COMP on page 134
COUN?	Reads out the BIN count value.	:CALC:COMP:COUN:DATA? on page 138 :CALC:COMP:COUN:OVLD? on page 140
CREJ0	Turns OFF the Low C reject function.	:CREJ on page 166
CREJ{1-6}	Sets the Low C detection boundary value for the Low C reject function.	:CREJ:LIM on page 167
CSTD=	Sets the Cp value of the standard for the standard (LOAD) compensation.	:CORR:CKIT:STAN3 on page 155
[D]		
DATA?	Reads out the measurement result.	:FETC? on page 181
DBIN{0 1}	Turns ON/OFF the simultaneous output of the comparator sorting result when reading out the measurement result.	N/A (dependent on the ON/OFF of the comparator function)
DDIG{4-6}	Sets the number of display digits for the measurement result.	:DISP:TEXT1:DIG on page 176
DEND	Turns OFF the continuous data output (spew-out mode).	N/A
DFMT{1 2}	Sets the data output (data transfer) format.	:FORM on page 182
DPAG{1-4}	Sets the display format on the display.	N/A
DST	Turns ON the continuous data output (spew-out mode).	N/A

Table B-25 At-a-glance list of GPIB command correspondence between 4278A and 4288A (alphabetical order)

4278A	Function overview	4288A
DSTD=	Sets the D value of the standard for the standard (LOAD) compensation.	:CORR:CKIT:STAN3 on page 155
DTIM=	Sets the delay time (trigger delay time).	:TRIG:DEL on page 195
DVAL{1 2}	Sets the display mode.	:CALC1:MATH:EXPR:NAME on page 148
[E]		
ERR?	Reads out the error message number.	:SYST:ERR? on page 192
[F]		
FREQ{1 2}	Sets the measurement frequency.	:SOUR:FREQ on page 187
[G]		
GSTD=	Sets the G value of the standard for the standard (LOAD) compensation.	:CORR:CKIT:STAN3 on page 155
[H]		
HIAC{0 1}	Turns ON/OFF the HI-ACC mode.	N/A
[I]		
ITIM{1-3}	Sets the integration time (measurement time).	:APER on page 130
[L]		
LMOD{1-3}	Sets the limit mode (limit range specification method).	:CALC:COMP:MODE on page 141
LOAD	Loads (recalls) the measurement condition.	*RCL on page 126
LPAR{1-6}	Sets the parameter to be sorted by the comparator.	N/A (Dependent on the measurement parameter and cannot be set up separately.)
[M]		
MCOM{0 1}	Turns ON/OFF multi-compensation.	:CORR:MULT on page 161
MPAR{1-6}	Sets the measurement parameter.	:CALC1:FORM on page 147, :CALC2:FORM on page 150
[N]		
NOM=	Sets the nominal value (reference value) in the tolerance mode.	:CALC:COMP:PRIM:NOM on page 144
[O]		
OFFA=	Sets the offset compensation value for the primary parameter.	:CORR:OFFS:DATA on page 164
OFFB=	Sets the offset compensation value for the secondary parameter.	
OPEN{0 1}	Turns ON/OFF the OPEN compensation.	:CORR:OPEN on page 165
OPM?	Reads out the measured OPEN compensation value (data for OPEN compensation).	:CORR:DATA on page 158
OSC=	Sets the OSC level (measurement signal level).	:SOUR:VOLT on page 188
[R]		
RA{0-7}	Sets the measurement range when the measurement frequency is 1 kHz.	:RANG on page 184
RB{0-11}	Sets the measurement range when the measurement frequency is 1 MHz.	:RANG:AUTO on page 185
RC=	Sets the measurement range value for the HI-ACC mode.	N/A
RCNT	Resets the BIN count value.	:CALC:COMP:COUN:CLE on page 137
REVP{0 1}	Turns ON/OFF the reverse parameter function.	N/A
[S]		

B. Information for Replacing 4278A with 4288A

Information for Replacing 4278A with 4288A
At-a-Glance List of GPIB Command Correspondence

Table B-25 At-a-glance list of GPIB command correspondence between 4278A and 4288A (alphabetical order)

4278A	Function overview	4288A
SHM?	Reads out the measured SHORT compensation value (data for SHORT compensation).	:CORR:DATA on page 158
SHOR{0 1}	Turns ON/OFF the SHORT compensation.	:CORR:SHOR on page 165
SLIM=	Sets the limit range of the secondary parameter.	:CALC:COMP:SEC:LIM on page 145
SPAR{1 2}	Sets the definition parameter of the standard for standard (LOAD) compensation.	:CORR:CKIT:STAN3:FORM on page 156
STD{0 1}	Turns ON/OFF standard (LOAD) compensation.	:CORR:LOAD on page 160
STM?	Reads out the measured standard compensation value (data for LOAD compensation).	:CORR:DATA on page 158
STOR	Stores (saves) the measurement condition.	*SAV on page 127
STR?	Reads out the standard compensation reference value (setup value of the standard for LOAD compensation).	:CORR:CKIT:STAN3 on page 155
[T]		
TRIG{1-3}	Sets the trigger mode.	:TRIG:SOUR on page 196
[V]		
VMON{0-6}	Sets the items to be displayed.	N/A
[X]		
XOP	Makes a measurement to obtain the measured OPEN compensation value (data for OPEN compensation).	:CORR:COLL on page 157
XSH	Makes a measurement to obtain the measured SHORT compensation value (data for SHORT compensation).	
XSTD	Makes a measurement to obtain the measured standard compensation value (data for LOAD compensation).	
XTMP	Executes the temperature compensation.	N/A
[*]		
*CLS	Clears the status byte register.	*CLS on page 124
*IDN?	Reads out the model name and firmware version.	*IDN? on page 125
*LRN?	Reads out the setup state.	N/A
*OPT?	Reads out the installed option number.	*OPT? on page 126
*RST	Resets the instrument.	:SYST:PRES on page 193
*SRE	Sets a mask (service request enable register) to the status byte register or reads out it.	*SRE on page 127
*STB?	Reads out the contents of the status byte register.	*STB? on page 128
*TRG	Triggers a measurement.	:TRIG on page 195

Table B-26 At-a-glance list of GPIB command correspondence between 4278A and 4288A (by function)

Item to Be Set Up/Executed		4278A	4288A		
Measurement condition	Reset	*RST	:SYST:PRES on page 193		
	Measurement parameter setup		MPAR{1-6}	:CALC1:FORM on page 147, :CALC2:FORM on page 150	
	Measurement signal setup	Measurement frequency	FREQ{1 2}	:SOUR:FREQ on page 187	
		OSC level (Measurement signal level)	OSC=	:SOUR:VOLT on page 188	
	HI-ACC mode setup	ON/OFF	HIAC{0 1}	N/A (The HI-ACC mode is not available.)	
		Measurement range value	RC=		
	Measurement range setup	When the measurement frequency is 1 kHz:	RA{0-7}	:RANG on page 184, :RANG:AUTO on page 185	
		When the measurement frequency is 1 MHz:	RB{0-11}		
	Integration time (measurement time) setup		ITIM{1-3}	:APER on page 130	
	Averaging count setup		AVE=	:AVER:COUN on page 132	
	Cable length setup		CABL{0-2}	:CAL:CABL on page 133	
	Delay time (trigger delay time) setup		DTIM=	:TRIG:DEL on page 195	
	Trigger mode setup		TRIG{1-3}	:TRIG:SOUR on page 196	
Compensation	OPEN compensation ON/OFF		OPEN{0 1}	:CORR:OPEN on page 165	
	SHORT compensation ON/OFF		SHOR{0 1}	:CORR:SHOR on page 165	
	STANDARD (LOAD) compensation ON/OFF		STD{0 1}	:CORR:LOAD on page 160	
	Offset compensation ON/OFF	Primary parameter	AOFF{0 1}	:CORR:OFFS on page 163 (The primary and secondary parameters cannot be turned ON/OFF separately.)	
		Secondary parameter	BOFF{0 1}		
	Standard for the standard (LOAD) compensation	Definition parameter setup	SPAR{1 2}	:CORR:CKIT:STAN3:FORM on page 156	
		Cp value setup	CSTD=	:CORR:CKIT:STAN3 on page 155	
		D value setup	DSTD=		
		G value setup	GSTD=		
	Setup value readout		STR?		
		Measurement to obtain the measured compensation value (data for compensation)	OPEN	XOP	:CORR:COLL on page 157
			SHORT	XSH	
			Standard (LOAD)	XSTD	
	Offset compensation value setup	Primary parameter	OFFA=	:CORR:OFFS:DATA on page 164	
		Secondary parameter	OFFB=		
Measured compensation value (data for compensation) readout	OPEN	OPM?	:CORR:DATA on page 158		
	SHORT	SHM?			
	Standard (LOAD)	STM?			
Temperature compensation execution		XTMP	N/A (No need for the temperature compensation.)		

B. Information for Replacing 4278A with 4288A

Information for Replacing 4278A with 4288A
At-a-Glance List of GPIB Command Correspondence

Table B-26 At-a-glance list of GPIB command correspondence between 4278A and 4288A (by function)

Item to Be Set Up/Executed		4278A	4288A	
Scanner (multi compensation)	ON/OFF	MCOM{0 1}	:CORR:MULT on page 161	
	Channel setup	CNO=	:CORR:MULT:CHAN on page 161	
Trigger	Triggers a measurement	*TRG	:TRIG on page 195	
	Trigger mode setup	TRIG{1-3}	:TRIG:SOUR on page 196	
	Delay time (trigger delay time) setup	DTIM=	:TRIG:DEL on page 195	
Measured data output	Data output (data transfer) format setup	DFMT{1 2}	:FORM on page 182	
	Measurement result readout	DATA?	:FETC? on page 181	
	Comparator sorting result output ON/OFF	DBIN{0 1}	N/A (dependent on the ON/OFF of the comparator function)	
	Continuous data output (spew-out mode)	Start	DST	N/A (The continuous data output function is not available. However, similar function can be using :READ? on page 186.)
End		DEND		
Comparator	ON/OFF	COMP{0 1}	:CALC:COMP on page 134	
	Sorting target parameter setup	LPAR{1-6}	N/A (Dependent on the measurement parameter and cannot be set up separately.)	
	Reverse parameter function ON/OFF	REVP{0 1}	N/A	
	Primary parameter limit range setup	Limit mode (limit range designation method)	LMOD{1-3}	:CALC:COMP:MODE on page 141
		In sequential mode	BLIM=	:CALC:COMP:PRIM:BIN{1-9} on page 142
		In tolerance mode	BIN{1-9}=	
		Nominal value (reference value) for tolerance mode	NOM=	:CALC:COMP:PRIM:NOM on page 144
	Secondary parameter limit range setup	SLIM=	:CALC:COMP:SEC:LIM on page 145	
	Limit range clear	CLIM	:CALC:COMP:CLE on page 136	
	AUX BIN function ON/OFF	AUX{0 1}	:CALC:COMP:AUXB on page 135	
	Low C reject function	OFF	CREJ0	:CREJ on page 166
		Low C detection boundary value setup	CREJ{1-6}	:CREJ:LIM on page 167
	BIN count function	ON/OFF	CNT{0 1}	:CALC:COMP:COUN on page 137
		Count value reset	RCNT	:CALC:COMP:COUN:CLE on page 137
		Count value readout	COUN?	:CALC:COMP:COUN:DATA? on page 138 :CALC:COMP:COUN:OVLD? on page 140
Count value readout for each channel		CCOU?	:CALC:COMP:COUN:MULT:DATA? on page 139 :CALC:COMP:COUN:MULT:OVLD? on page 140	
Save/recall	Measurement condition storage (save)	STOR	*SAV on page 127	
	Measurement condition load (recall)	LOAD	*RCL on page 126	

Table B-26 **At-a-glance list of GPIB command correspondence between 4278A and 4288A (by function)**

Item to Be Set Up/Executed		4278A	4288A
Display	Display format setup	DPAG{1-4}	N/A
	Setup of the number of display digits for the measurement result	DDIG{4-6}	:DISP:TEXT1:DIG on page 176
	Display mode setup	DVAL{1 2}	:CALC1:MATH:EXPR:NAME on page 148
	Displayed item setup for the monitor display area	VMON{0-6}	N/A
Status byte register	Clear	*CLS	*CLS on page 124
	Mask (service request enable register setup or readout)	*SRE	*SRE on page 127
	Readout of register contents	*STB?	*STB? on page 128
Others	Readout of model name and firmware version	*IDN?	*IDN? on page 125
	Readout of installed option number	*OPT?	*OPT? on page 126
	Readout of error message number	ERR?	:SYST:ERR? on page 192
	Setup state readout	*LRN?	N/A (The query is available for all the setup commands. Therefore, use each command for reading out.)

Comparison of Interfaces

Handler interface

Figure B-2

Pin Assignment

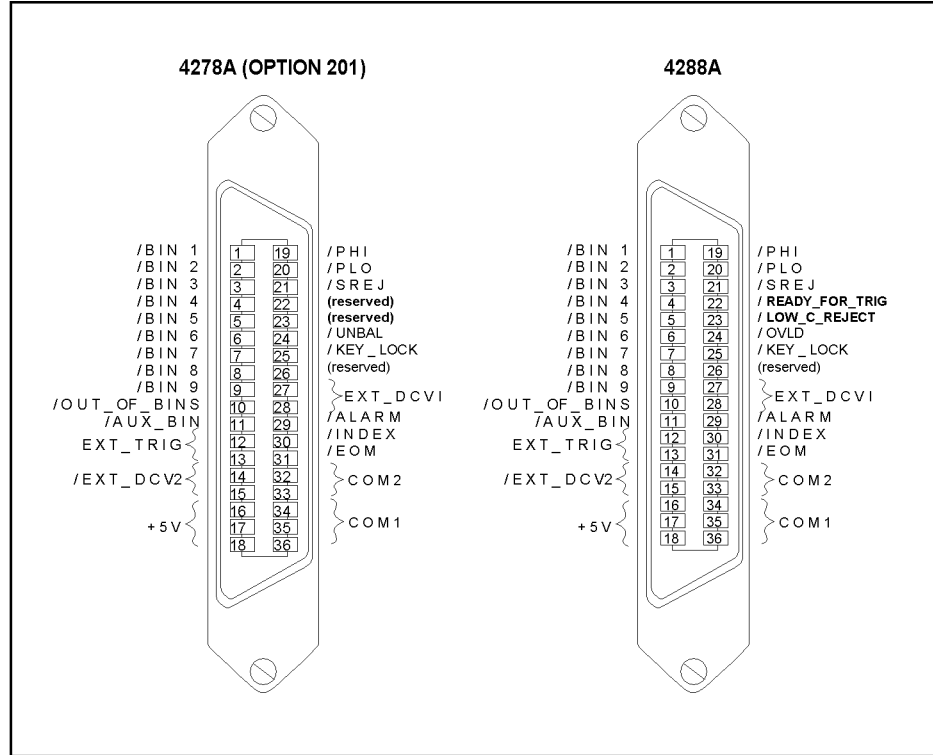

Table B-27

Factory setting

	4278A	4288A
Selection of judgment output signal pull-up power supply	External power supply (5 V to 24 V)	External power supply (5 V to 24 V)
Selection of operation output signal pull-up power supply	External power supply (5 V to 15 V)	External power supply (5 V to 24 V)
Voltage range of input signal drive power supply	9 V to 15 V	15 V to 24 V

Scanner interface

Figure B-3

Pin Assignment

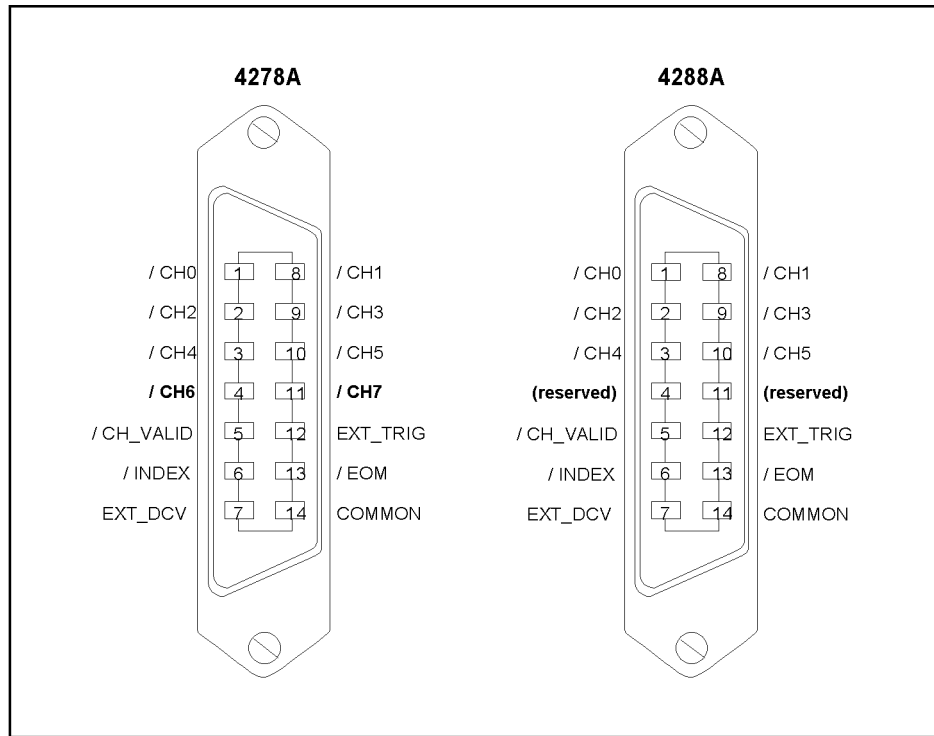

4288apj010

B. Information for Replacing 4278A with 4288A

Table B-28

Factory setting

	4278A	4288A
Voltage range of input signal drive power supply	5 V to 6 V	9 V to 15 V

Information for Replacing 4278A with 4288A
Comparison of Interfaces

C **Status Reporting System**

This appendix describes the status reporting system of the Agilent 4288A.

General Status Register Model

The Agilent 4288A has a status reporting system for monitoring the instrument's condition.

Figure C-1 General Status Register Model

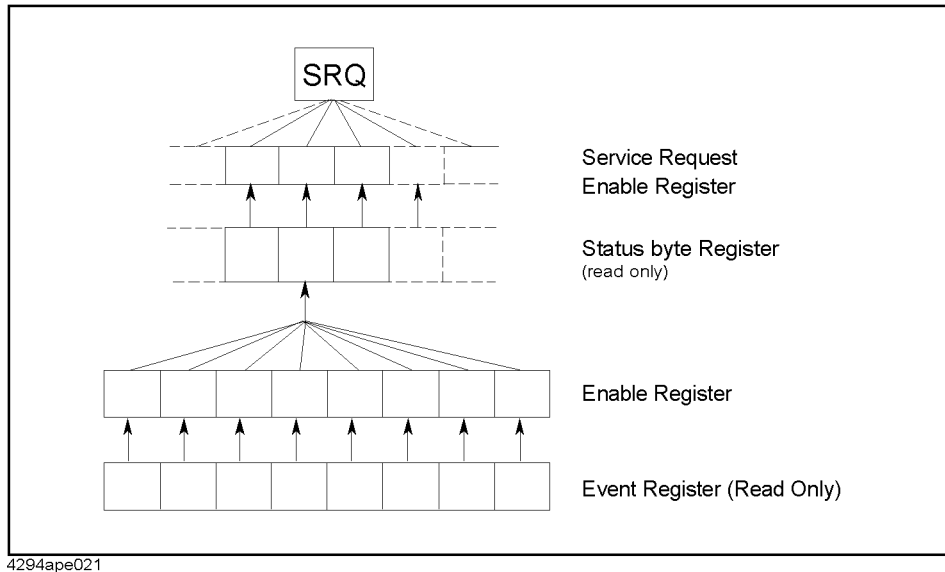

The status reporting system has the hierarchical structure shown in Figure C-1. When the instrument satisfies a particular condition, the corresponding bit of the event register is set to “1.” Therefore, you can check the instrument status by reading the event register.

When the event register bit is set to “1” and a corresponding enable register bit (a bit marked with an arrow in Figure C-1) is also “1,” the summary bit of the status byte register is set to “1.” You can read the status byte register by using the serial poll.

If the bit of the service request enable register is “1,” a service request (SRQ) is generated by the positive transition of the corresponding status byte register bit. By generating an SRQ, you can notify the controller that the 4288A is requesting service. In other words, you can program interruption by using an SRQ. For more information on using SRQ, see “Waiting For Completion Of Measurement (detecting completion of measurement)” on page 55 in Chapter 5 or “Detecting the occurrence of an error” on page 95 in Chapter 8.

Event register

The event register reflects the corresponding condition of the 4288A (e.g., occurrence of an event) as a bit status. These bits continuously monitor changes in the 4288A's state and change the bit status when the condition (e.g., change bit status to "1" if a specific event occurs) for each bit is met. You cannot change the bit status by issuing a GPIB command.

The Agilent 4288A has the following event registers:

- Standard Event Status Register (see Table C-2 for details.)
- Operation Status Event Register (see Table C-3 for details.)

Enable register

Setting the enable register allows you to specify event register bits that can set "1" to the summary bit of the status byte register when an event occurs. The register bits work as mask bits; setting "1" to an enable register will enable a corresponding bit in the event register.

For example, when you want to set "1" as the summary bit in the status byte register by a specific register condition, set the corresponding enable register to "1."

Status byte register

If the enabled event register is set to "1," a corresponding bit of the status byte register is also set to "1." This register also indicates the output queue and SRQ status.

The value of the status byte register can be read by using the ***STB?** command on page 128 or the serial poll (SPOLL statement in HTBasic) from the controller. The ***STB?** command sets the analyzer to remote mode. On the other hand, the SPOLL statement in HTBasic reads the status byte register value directly without the instrument being set to remote. Therefore, you can continue to operate the front panel keys while a controller is reading the status byte register.

Reading the status byte register by using the ***STB?** command does not affect the contents of the status byte register. However, reading it with the SPOLL statement of HTBasic will clear the RQS bit in the status byte register.

Setting the service request enable register using the ***SRE** command on page 127 can generate a service request synchronously with the status byte register.

Condition register and transition filter

When the status register has a transition filter, there is a lower register called a condition register under the event register. The transition filter is between the event register and the condition register.

The transition filter enables you to select a positive and/or negative transition of the condition register bit in order to set a bit in the corresponding event register. For example, using the negative transition filter to set bit 3 to “1” causes bit 3 of the event register to be set to “1” when bit 3 of the condition register makes a negative transition, that is, changes from 1 to 0.

Figure C-2

Transition filter and condition register

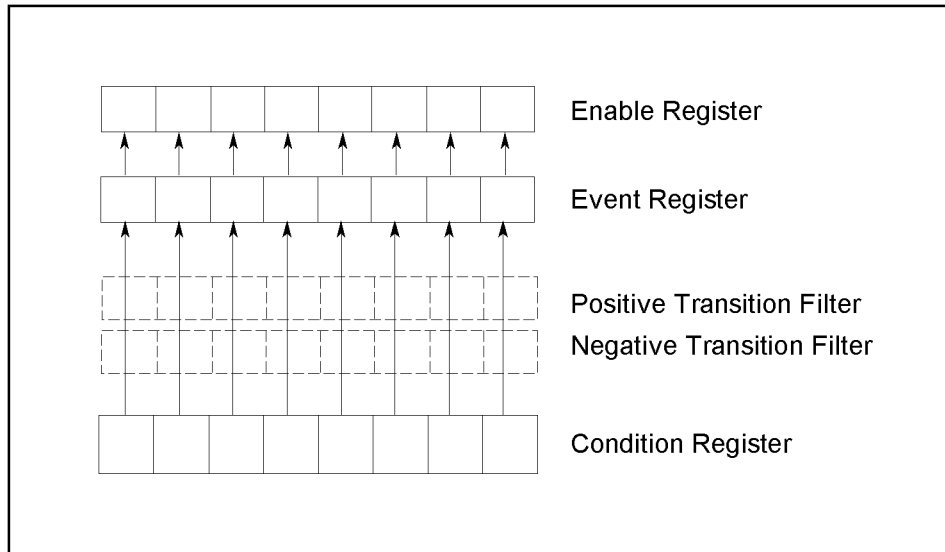

4294ape022

The 4288A's condition register and transition filter work only with the operation status register. However, the 4288A's transition filter's setting is fixed so that bits 5, 8, 9, 10 of the event register are set to “1” when the condition register makes a positive transition (i.e., changes from 0 to 1) and bits 1, 2, 3, 4, 7, 12 of the event register are set to “1” when the condition register makes a negative transition (i.e., changes from 1 to 0).

Status Register Structure

The status reporting system has the hierarchical structure shown in Figure C-3. The status byte register is a summary of registers in the lower level. This section describes the status registers in each hierarchy. Each bit of the status register is described in Table C-1 through Table C-3.

Figure C-3 Status Register Structure

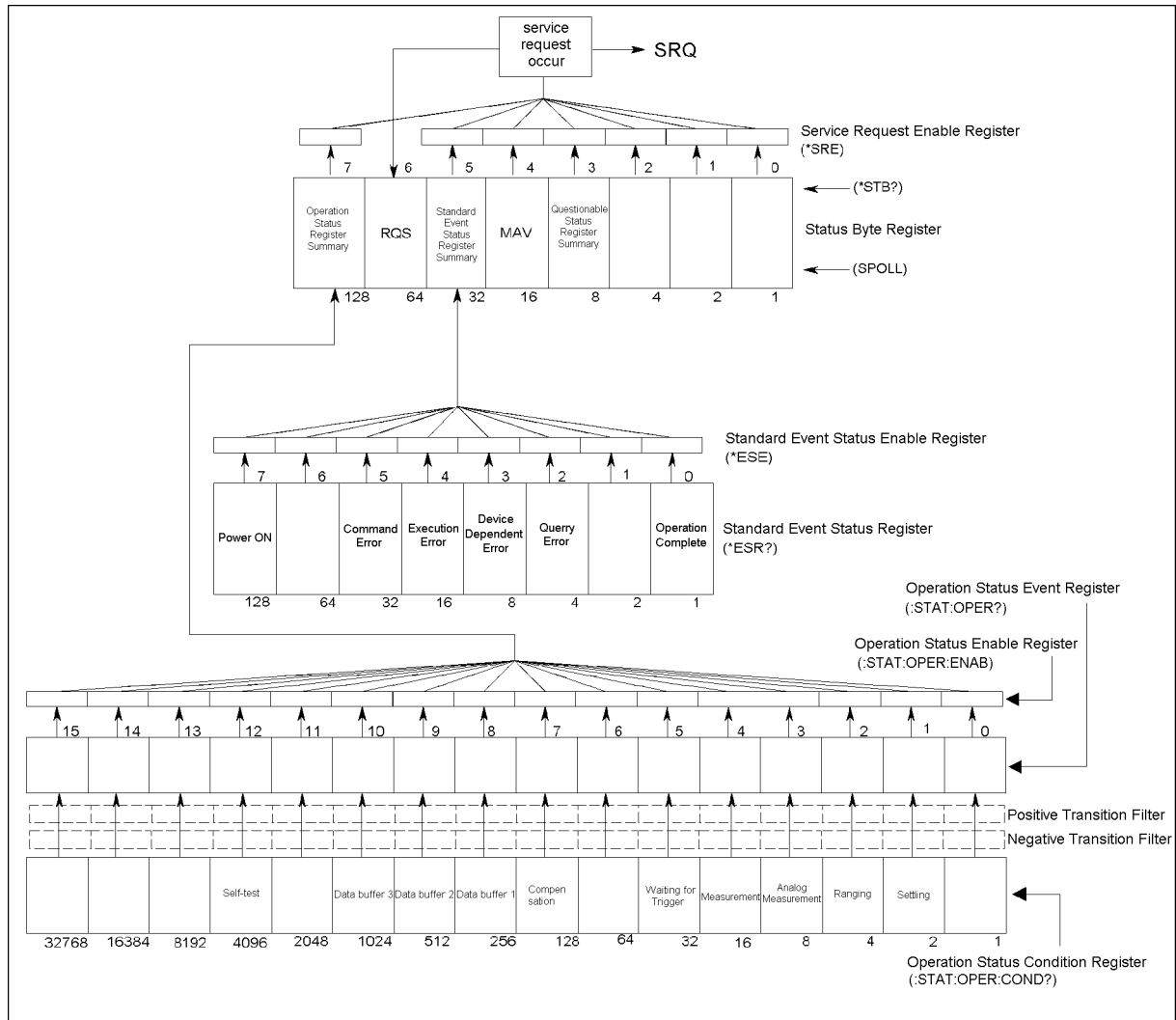

4288ape013

Status Reporting System
Status Register Structure

Table C-1 **Status Bit Definitions of Status Byte (STB)**

Bit Position	Name	Description
0 to 2	Not used	Always 0
3	Questionable Status Register Summary	Set to "1" when one of the enabled bits in the status event status register is set to "1."
4	MAV (Message Available)	Set to "1" when the output queue contains data; reset to "0" when all of the data has been retrieved.
5	Standard Event Status Register Summary	Set to "1" when one of the enabled bits in the status event status register is set to "1."
6	RQS	Set to "1" when any of the status byte register bits enabled by the service request enable register is set to "1"; reset to "0" when all of the data has been retrieved through serial polling.
7	Operation Status Register Summary	Set to "1" when one of the enabled bits in the operational status register is set to "1."

Issuing the ***CLS** command will clear all bits from the status byte register.

Table C-2 Status Bit Definitions of Event Status Register (ESR)

Bit Position	Name	Description
0	Operation Complete	Set to "1" upon completion of all operations done by commands that precede the *OPC command on page 125.
1	Not used	Always 0
2	Query Error	<ol style="list-style-type: none"> Set to "1" when the 4288A receives a data output request but there is no data to output. Set to "1" when the data of the 4288A's output queue has been cleared because of a new message received before the completion of data output.
3	Device Dependent Error	Set to "1" when an error has occurred and the error is not a command, query, or execution error.
4	Execution Error	<ol style="list-style-type: none"> Set to "1" when any parameter in a GPIB command exceeds its input range or is inconsistent with the 4288A's capabilities. Set to "1" when a GPIB command cannot be properly executed due to some condition of the 4288A.
5	Command Error	<ol style="list-style-type: none"> Set to "1" when an IEEE 488.2 syntax error occurs (a command sent to the 4288A does not follow the IEEE 488.2 syntax). Possible violations include the command parameter violating the 4288A listening formats or being otherwise unacceptable. Set to "1" when a semantic error occurs. Possible errors include a command containing misspellings or an IEEE 488.2 command that is not supported by the 4288A. Set to "1" when GET (Group Execution Trigger) is input while a program message is being received.
6	Not used	Always 0
7	Power ON	Set to "1" when the 4288A is powered ON.

Issuing the *CLS command will clear all bits from the standard event status register.

Table C-3 Status Bit Definitions of the Operation Status Register

Bit Position	Name	Description	
		Condition Register	Event Register
0	Not used	Always 0	Always 0
1	Settling	Set to “1” during the waiting time to stabilize the measurement signal.	Set to “1” after the waiting time needed to stabilize the measurement signal has elapsed.
2	Ranging	Set to “1” while switching the measurement range.	Set to “1” when measurement range switching is completed.
3	Analog Measurement	Set to “1” during analog measurement ^{*1} .	Set to “1” when analog measurement is completed.
4	Measurement	Set to “1” during measurement ^{*2} .	Set to “1” when measurement is completed.
5	Waiting for Trigger	Set to “1” while the instrument is waiting for a trigger ^{*3} .	Set to “1” when the instrument starts waiting for a trigger.
6	Not used	Always 0	Always 0
7	Compensation	Set to “1” during compensation data measurement.	Set to “1” when the compensation data measurement is completed.
8	Data buffer 1	Set to “1” while data buffer 1 fills.	Set to “1” when data buffer 1 is full.
9	Data buffer 2	Set to “1” while data buffer 2 fills.	Set to “1” when data buffer 2 is full.
10	Data buffer 3	Set to “1” while data buffer 3 fills.	Set to “1” when data buffer 3 is full.
11	Not used	Always 0	Always 0
12	Self-test	Set to “1” during self-test.	Set to “1” when self-test is completed.
13 to 15	Not used	Always 0	Always 0

*1. This is when the handler interface’s /INDEX signal is active.

*2. This is when the handler interface’s /EOM signal is active.

*3. This is when the trigger system is in trigger wait state. For more information on the trigger system, refer to “Trigger system” on page 52.

Issuing the ***CLS** command will clear all bits from the operation status event register.

The 4288A does not support events of the questionable status register. Therefore, all of the bits in this register are always 0.

Table C-4 Status Bit Definitions of the Questionable Status Register

Bit Position	Name	Description	
		Condition Register	Event Register
0 to 15	Not used	Always 0	Always 0

Using the Status Reporting System

You can manage the status report system by using the following commands in any combination:

- ***CLS** on page 124
- ***SRE** on page 127
- ***STB?** on page 128
- ***ESE** on page 124
- ***ESR?** on page 125
- **:STAT:PRES** on page 190
- **:STAT:OPER:ENAB** on page 189
- **:STAT:OPER:COND?** on page 189
- **:STAT:OPER?** on page 189

For sample programs that demonstrate the use of the commands listed above, refer to “Waiting For Completion Of Measurement (detecting completion of measurement)” on page 55 in Chapter 5 or “Detecting the occurrence of an error” on page 95 in Chapter 8.

Status Reporting System
Using the Status Reporting System

D Initial Settings

This appendix provides initial settings, settings that can be saved/recalled, and settings that can be backed up.

Initial Settings, Settings that can be Saved/Recalled, Settings that can be Backed Up

The columns of Table D-1 show the following items.

- Initial settings (factory settings)
- Settings reset from the front panel or the GPIB by the **:SYST:PRES** command on page 193
- Settings reset from the GPIB by the ***RST** command on page 126
- Settings that can be saved/recalled

Table D-1 uses the following symbols.

- : Settings that can be saved/recalled
 - ×: Settings that cannot be saved/recalled
- Settings that can be backed up

Table D-1 uses the following symbols.

- : Settings that can be backed up in the back-up memory (maximum 72 hours)
- : Settings that can be backed up in the EEPROM
- ×: Settings that cannot be backed up

The symbol “←” in Table D-1 indicates that the value is the same as that indicated to the left.

Table D-1 Initial settings, settings that can be saved/recalled, settings that can be backed up

Setting items		Initial settings (factory settings)	Reset		Save/ Recall	Backup		
			Front panel key (:SYST:PRES)	*RST				
Measurement parameter	Primary parameter	CP	←	←	●	○		
	Secondary parameter	D	←	←	●	○		
Measurement signal	Frequency	1 kHz	←	←	●	○		
	Level	1 V	←	←	●	○		
	1 MHz frequency shift	0%	No effect	←	×	●		
Measurement range	Ranging	Auto	←	←	●	○		
	Range setup	1 nF range	←	←	●	○		
Measurement time mode		LONG mode	←	←	●	○		
Averaging	ON/OFF	ON	←	←	●	○		
	Number of counts	1	←	←	●	○		
Cable length		0	←	←	●	●		
Trigger	Mode	Int	←	←	●	○		
	Trigger delay time	0	←	←	●	○		
	Continuous activation (:INIT:CONT) ON/OFF	ON	←	OFF	×	×		
OPEN compensation	ON/OFF		OFF	No effect	OFF	●	○	
	Compensation data	Primary parameter	1 kHz	0 S	No effect	0 S	●	●
			1 MHz	0 S	No effect	0 S	●	●
		Secondary parameter	1 kHz	0 S	No effect	0 S	●	●
			1 MHz	0 S	No effect	0 S	●	●
	Parameter type		Primary	G	No effect	G	●	●
Secondary			B	No effect	B	●	●	
SHORT compensation	ON/OFF		OFF	No effect	OFF	●	○	
	Compensation data	Primary parameter	1 kHz	0 Ω	No effect	0 Ω	●	●
			1 MHz	0 Ω	No effect	0 Ω	●	●
		Secondary parameter	1 kHz	0 Ω	No effect	0 Ω	●	●
			1 MHz	0 Ω	No effect	0 Ω	●	●
	Parameter type		Primary	R	No effect	R	●	●
Secondary			X	No effect	X	●	●	
LOAD compensation	ON/OFF		OFF	No effect	OFF	●	○	
	Compensation data	Primary parameter	1 kHz	100 nF	No effect	100 nF	●	●
			1 MHz	100 pF	No effect	100 pF	●	●
		Secondary parameter	1 kHz	0	No effect	0	●	●
			1 MHz	0	No effect	0	●	●
	LOAD standard definition	Primary parameter	1 kHz	100 nF	No effect	100 nF	●	●
			1 MHz	100 pF	No effect	100 pF	●	●
		Secondary parameter	1 kHz	0	No effect	0	●	●
			1 MHz	0	No effect	0	●	●
	Parameter type		Primary	CP	No effect	CP	●	●
Secondary			D	No effect	D	●	●	
Offset compensation	ON/OFF		OFF	No effect	OFF	●	○	
	Compensation data	Primary parameter	1 kHz	0 F	No effect	0 F	●	●
			1 MHz	0 F	No effect	0 F	●	●
		Secondary parameter	1 kHz	0	No effect	0	●	●
			1 MHz	0	No effect	0	●	●

Initial Settings

Initial Settings, Settings that can be Saved/Recalled, Settings that can be Backed Up

Table D-1 Initial settings, settings that can be saved/recalled, settings that can be backed up

Setting items			Initial settings (factory settings)	Reset		Save/ Recall	Backup	
				Front panel key (:SYST:PRES)	*RST			
Multi compensation	ON/OFF		OFF	No effect	OFF	●	○	
	Channel number		0	No effect	0	●	○	
	LOAD standard definition method (Single/Multi)		Single	No effect	Single	●	○	
Data transfer format			ASCII	←	←	×	×	
Data buffer	Feeding target parameter		None	←	←	×	×	
	Control (feed/not feed)		Not feed	←	←	×	×	
	Size	Buffer 1 or Buffer 2	200	←	←	×	×	
		Buffer 3	1000	←	←	×	×	
Comparator	ON/OFF		OFF	←	←	●	○	
	Limit range ON/OFF	BIN1	ON	←	←	●	○	
		BIN2 to BIN9		OFF	←	←	●	○
		Secondary parameter		ON	←	←	●	○
	Limit range setting	Upper limit value		0	←	←	●	○
		Lower limit value		0	←	←	●	○
		Limit range designation method (mode selection)		ABS	←	←	●	○
		Reference (nominal) value		0	←	←	●	○
	AUX BIN ON/OFF			OFF	←	←	●	○
	Low C reject	ON/OFF		OFF	←	←	●	○
		Limit value		0%	←	←	●	○
BIN count	ON/OFF		OFF	←	←	●	○	
	Count value		0	←	←	×	×	
Measurement signal level monitor	Current		OFF	←	←	●	○	
	Voltage		OFF	←	←	●	○	
Display	ON/OFF		ON	←	←	●	○	
	Number of digits		6	←	←	●	○	
	Fixed point display	ON/OFF		OFF	←	←	●	○
		Value of the highest digit (Msd)	Primary parameter	1 nF	←	←	●	○
			Secondary parameter	1	←	←	●	○
	Deviation measurement mode	ON/OFF		OFF	←	←	●	○
		Mode		DEV	←	←	●	○
Reference value		0	←	←	●	○		
Page number of instrument setup display area			1	←	←	●	○	
Key lock ON/OFF			OFF	No effect	OFF	×	×	
Beeper	ON/OFF		ON	←	←	●	○	
	Mode		FAIL	←	←	●	○	
Standard event status enable register value			0	No effect	←	×	×	
Service request enable register value			0	No effect	←	×	×	
Operation status enable register value			0	←	←	×	×	
GPIB address			17	No effect	←	×	●	

NOTE

The OPEN/SHORT/LOAD compensation data and the LOAD standard definition settings for multi-compensation are not reset regardless of the resetting method used.

E At-a-glance Table of Operations When Overload or Low C is Detected

This appendix describes display output, GPIB output, and handler interface output when an overload or Low C is detected.

Operations when overload/Low C is detected

Table E-1 shows operations of the 4288A when one of the following items is detected:

- ❑ Overload:
 - When the available measurement range is exceeded more than 18% (refer to “Specifications and Supplemental Performance Characteristics” in *Operation Manual*)
 - When nothing is connected to the UNKNOWN terminal
- ❑ Low C:
 - When measured primary parameter result is equal to or less than the boundary value specified for the Low C reject function
- ❑ Out of display range:
 - When measured result exceeds the allowable display range (refer to “Specifications and Supplemental Performance Characteristics” in *Operation Manual*) (regardless of fixed or floating point display)
 - When measured result exceeds the allowable display range for the fixed point display

Table E-1 At-a-glance table of operations when overload/Low C reject is detected

	Display output			GPIB output			Handler output (handler signal that becomes active)
	Measured value	Voltage/ current monitor value	Comparator sorting result	Measurement status	Measured value	Comparator sorting result	
Overload	OVLD	***	****	1	9.9E37	11	/OVLD
Low C	Normal	Normal	LOWC	2	Normal	Normal	/LOW_C_REJECT*1
Out of display range*2	-----	---	Normal	Normal	Normal	Normal	Normal

*1./LOW_C_REJECT becomes active together with the signal that corresponds to the result of normal sorting judgment (judgment result when no error occurred).

*2. When an out-of-display-range state is detected, measurement is performed normally but the measured values are not displayed.

F Error Messages

The Agilent 4288A provides error messages to indicate its operating status. This appendix describes the error messages of the 4288A in order of error number. To search for error messages alphabetically, refer to the *Operation Manual*.

Error messages (order of error number)

Error messages are displayed in the lower row of the 4288A's display. You can read them out by using the GPIB command. This section provides a description of each error message and its remedy.

NOTE

Errors with a negative error number are basically general errors defined by IEEE488.2 for GPIB instruments. On the other hand, errors with a positive error number are defined specifically for the 4288A.

0

(No error)

No error has occurred.

This message is not displayed on the LCD. 0 is returned as the error number if no error has occurred in the instrument when the **:SYST:ERR?** command on page 192 is sent through GPIB.

11

RAM test failed

The RAM test at power-on has failed.

If this error occurs, the 4288A makes a beep sound and stops. The hardware is at fault and needs repair.

Contact an Agilent Technologies sales office or the VAR from which you purchased the instrument.

12

BOOT ROM test failed

The boot ROM test at power-on has failed.

If this error occurs, the 4288A makes a beep sound and stops. The hardware is at fault and needs repair.

Contact an Agilent Technologies sales office or the VAR from which you purchased the instrument.

13

The flash ROM test at power-on has failed.

If this error occurs, the 4288A makes a beep sound and stops. The hardware is at fault and needs repair.

Contact an Agilent Technologies sales office or the VAR from which you purchased the instrument.

14

EEPROM test failed

The EEPROM test at power-on has failed.

If this error occurs, the 4288A makes a beep sound and stops. The hardware is at fault and needs repair.

Contact an Agilent Technologies sales office or the VAR from which you purchased the instrument.

15

A1 board test failed

The A1 board test at power-on has failed.

If this error occurs, the 4288A makes a beep sound and stops. The hardware is at fault and needs repair.

Contact an Agilent Technologies sales office or the VAR from which you purchased the instrument.

16

ADC failure

A problem has occurred in the A/D converter during measurement.

If this error occurs, the 4288A makes a beep sound and stops. The hardware is at fault and needs repair.

Contact an Agilent Technologies sales office or the VAR from which you purchased the instrument.

17

Fan stopped

The fan has stopped.

If this error occurs, the 4288A makes a beep sound and stops. The hardware is at fault and needs repair.

Contact an Agilent Technologies sales office or the VAR from which you purchased the instrument.

18

Calibration memory lost

The calibration data in EEPROM has been lost at power-on.

If this error occurs, the 4288A makes a beep sound and stops. The hardware is at fault and needs repair.

Contact an Agilent Technologies sales office or the VAR from which you purchased the instrument.

19

User data lost

The compensation data in EEPROM has been lost at power-on.

The compensation data is initialized to the factory-shipped state. Possible causes include the hardware being at fault or the power being turned OFF during write to EEPROM.

Contact an Agilent Technologies sales office or the VAR from which you purchased the instrument.

20

Previous setting lost

The instrument setup values in backup memory have been lost at power-on.

These values are initialized to the factory-shipped state. No beep sound is made. Possible causes include 72 hours or more elapsing since turning OFF the power or the hardware becoming faulty.

Error Messages
Error number: 21

21

Save failed

Saving the instrument setup into EEPROM has failed.

Although the 4288A will not stop due to this error, the hardware is at fault and needs repair.

Contact an Agilent Technologies sales office or the VAR from which you purchased the instrument.

22

Recall failed

Recalling the instrument setup from EEPROM has failed.

This error occurs when no instrument setup has been saved in the specified register on EEPROM. The instrument setup does not change and stays in the state as before executing the recall.

Confirm that you specified the correct register number when executing the recall.

23

Lockout by handler

Entry using the front panel keys has been disabled through the handler.

You cannot clear this state by using the front panel keys or GPIB command.

Set the /KEY_LOCK signal of the handler interface to HIGH.

25

Correction meas failed

A measurement failure has occurred during measuring the compensation data.

If this error occurs, the compensation data before the measurement remains with no change.

Confirm that you have made the correct connection for measuring the compensation data and have performed the compensation procedure correctly.

- 100 **Command error**
A comprehensive syntax error has occurred for which the 4288A cannot detect further details of the error. This error code simply indicates the occurrence of a command error that is defined in IEEE488.2,11.5.1.1.4.
- 101 **Invalid character**
Invalid characters have been found in the program message string. For example, in a correct program message “:CALC1:FORM CP”, an ampersand (&) is inserted by mistake to give “:CALC1:FORM&CP”.
- 102 **Syntax error**
There is a command or data type that cannot be recognized. For example, in the program message “:SYST:PRES”, a colon (:) is inserted by mistake to give “:SYST: :PRES”.
- 103 **Invalid separator**
The parser (syntax analysis program) expects a separator, but a character other than a separator has been sent. For example, although the correct way is to use “;” to separate two sent program messages such as “:CALC1:FORM CP;*OPC?”, the semicolon (;) needed to separate the program messages is missing to give “:CALC1:FORM CP *OPC?”.
- 104 **Data type error**
The parser has recognized impossible data elements. For example, numeric value or string data is expected, but block data is sent.
- 105 **GET not allowed**
A group execution trigger (GET) has been received in a program message. (Refer to IEEE488.2,7.7.)
- 108 **Parameter not allowed**
The number of parameters is larger than required by the command. For example, although the :CREJ:LIM command requires one parameter such as “:CREJ:LIM 3”, two parameters are added to give “:CREJ:LIM 0,3”.
- 109 **Missing parameter**
The number of parameters is less than required by the command. For example, although the :CREJ:LIM command requires one parameter such as “:CREJ:LIM 3”, no parameter is added to give “:CREJ:LIM”.
- 112 **Program mnemonic too long**
The length of the header exceeds 12 characters. (Refer to IEEE488.2,7.6.1.4.1.)
- 113 **Undefined header**
A header not defined for the 4288A has been received. For example, “*XYZ”, which is not defined for the 4288A, is received.

Error Messages
Error number: -121

- 121 **Invalid character in number**
An invalid character for the data type of the syntax analysis target has been received. For example, alphabetical characters exist in a decimal value or “9” exists in octal data.
- 123 **Exponent too large**
The absolute value of the exponent has exceeded 32,000. (Refer to IEEE488.2,7.7.2.4.1.)
- 124 **Too many digits**
The number of digits of the mantissa of the decimal value data element exceeds 255 except for preceding 0s. (Refer to IEEE488.2,7.7.2.4.1.)
- 128 **Numeric data not allowed**
A numeric value data element (that does not violate the standard) has been received where the 4288A does not accept any numeric value data element.
- 131 **Invalid suffix**
The suffix does not meet the syntax defined in IEEE488.2,7.7.3.2 or is inappropriate for the 4288A.
- 138 **Suffix not allowed**
A suffix is added to a numeric value element that does not permit a suffix.
- 140 **Character data error**
An error not included in the error numbers between -141 and -149 has occurred during the syntax analysis of a character data element.
- 141 **Invalid character data**
Invalid characters have been found in a character data element or the received parameter is not valid. For example, though a correct program message was “:CALC1:FORM CP,” a wrong program message, “:CALC1:FORM RP,” was received.
- 144 **Character data too long**
The length of the character data element has exceeded 12 characters. (Refer to IEEE488.2,7.7.1.4.)
- 148 **Character data not allowed**
A character data element (that does not violate the standard) has been received where the 4288A does not accept any character data element.
- 150 **String data error**
An error not included in the error numbers between -151 and -159 has occurred during the syntax analysis of a string data element.
- 151 **Invalid string data**
Character string data are expected, but the string data received are invalid for some reason. (Refer to IEEE488.2,7.7.5.2.) For example, the END message is received before the end quotation mark character appears.

- 158 **String data not allowed**
A string data element has been received where the 4288A does not accept any string data element. For example, a parameter must be enclosed with double quotation marks (“...”) but they are missing.
- 160 **Block data error**
An error not included in the error numbers between -161 and -169 has occurred during the syntax analysis of block data.
- 161 **Invalid block data**
Block data are expected, but the block data received are invalid for some reason. (Refer to IEEE488.2,7.7.6.2.) For example, the END message is received before the length of the block data is reached.
- 168 **Block data not allowed**
A block data element has been received where the 4288A does not accept any block data element.
- 170 **Expression error**
An error not included in the error numbers between -171 and -179 has occurred during the syntax analysis of equation data.
- 171 **Invalid expression**
The equation data element is invalid. (Refer to IEEE488.2,7.7.7.2.) For example, parentheses are not paired or a character violates the standard.
- 178 **Expression data not allowed**
An equation data element has been received where the 4288A does not accept any equation data element.
- 200 **Execution error**
A comprehensive execution error has occurred for which the 4288A cannot detect further details. This error code simply indicates the occurrence of an execution error that is defined in IEEE488.2,11.5.1.1.5.
- 211 **Trigger ignored**
A trigger command or trigger signal has been received and recognized by the 4288A, but it is ignored due to the timing relationship with the 4288A. For example, this happens when the 4288A’s trigger system is not in the Waiting for Trigger state.
- 213 **Init ignored**
Another measurement has been being executed and the measurement start request (:INIT command on page 183) has been ignored.
- 214 **Trigger deadlock**
Indicates that the :READ? command on page 186 was ignored because the trigger source setting was MAN or BUS.

Error Messages
Error number: -220

-220

Parameter error

An error not included in the error numbers between -221 and -229 has occurred during the analysis of a program data element. This error occurs, for example, when you attempt to specify invalid values (values not finite when converted to an R-X format impedance value) as the LOAD correction data or LOAD correction reference data. If this error occurs, the command is ignored. This error also occurs when you attempt to specify an invalid LOAD correction reference value by using the front panel keys.

Parameter Type Setting		Values not finite when converted to an R-X format impedance value
Primary Parameter	Secondary Parameter	
Cp	D	Independent of D value, Cp is 0
Cp	Q	Independent of Q value, Cp is 0, also Independent of Cp value, Q is 0
Cp	G	Cp and G are both 0
Cp	Rp	Independent of Cp value, Rp is 0
Cs	D	Independent of D value, Cs is 0
Cs	Q	Independent of Q value, Cs is 0, also Q is 0 independent of Cs value
Cs	Rs	Cs is 0 independent of Rs value

-221

Setting conflict

A program data element complying with the syntax standard has been analyzed, but the 4288A cannot execute it at present.

-222

Data out of range

A data element (that does not violate the standard) has been received out of the range defined for the 4288A.

-223

Too much data

The received block, equation, or string type program data complies with the standard, but the amount of data exceeds the limit that the 4288A can handle due to memory or device-specific conditions related to memory.

-230

Data corrupt or stale

The data is invalid or a newly initiated read operation has not been completed since the latest access.

-241

Hardware missing

The received command or Query complied with the standard but could not be executed due to hardware-related reasons (for example, an option was not installed).

- 310 **System error**
One of the “system errors” defined for the 4288A occurs.
- 311 **Memory error**
An error has been detected in the memory of the 4288A.
- 350 **Queue overflow**
The queue contains a certain code other than the code that caused this error. This indicates that an error has occurred due to insufficient space in the queue but has not been recorded.
- 400 **Query error**
A comprehensive Query error has occurred for which the 4288A cannot detect further details. This code simply indicates the occurrence of a Query error that is defined in IEEE488.2,11.5.1.1.7 and 6.3.
- 410 **Query INTERRUPTED**
This indicates the status that causes an “INTERRUPTED” Query error. (Refer to IEEE488.1,6.3.2.3.) This error occurs, for example, when data byte (DAB) or GET is received after Query but before the response has been completely sent.
- 420 **Query UNTERMINATED**
This indicates the status that causes an “UNTERMINATED” Query error. (Refer to IEEE488.2,6.3.2.) This error occurs, for example, when the 4288A is specified as a talker and an incomplete program message is received.
- 430 **Query DEADLOCKED**
This indicates the status that causes a “DEADLOCKED” Query error. (Refer to IEEE488.2,6.3.1.7.) This error occurs, for example, when both input and output buffers become full and the 4288A cannot continue processing.
- 440 **Query UNTERMINATED after indefinite response**
In a certain program message, a Query that requests an ambiguous response has not yet been completely executed when a different Query is received. (Refer to IEEE488.2,6.5.7.5.7.)

Warning Messages (WARNING)

Warning messages are displayed to warn users. They are displayed in the lower row of the display of the 4288A. You cannot read them out using the GPIB command.

WARNING: Need corr meas

When the OPEN compensation, SHORT compensation or LOAD compensation is ON, this is displayed when you change the setup of the cable length or measurement frequency shift (1 MHz). In this case, the OPEN compensation, SHORT compensation and LOAD compensation are automatically turned OFF.

WARNING: Need load meas

This is displayed when you turn ON the LOAD compensation from the front panel although the setups of the cable length and measurement frequency shift (1 MHz) differ from those when measuring/setting up the LOAD compensation data. In this case, the LOAD compensation is turned ON, but you need to measure the LOAD compensation data again for accurate measurement.

WARNING: Need open meas

This is displayed when you turn ON the OPEN compensation from the front panel although the setups of the cable length and measurement frequency shift (1 MHz) differ from those when measuring/setting up the OPEN compensation data. In this case, the OPEN compensation is turned ON, but you need to measure the OPEN compensation data again for accurate measurement.

WARNING: Need short meas

This is displayed when you turn ON the SHORT compensation from the front panel although the setups of the cable length and measurement frequency shift (1 MHz) differ from those when measuring/setting up the SHORT compensation data. In this case, the SHORT compensation is turned ON, but you need to measure the SHORT compensation data again for accurate measurement.

WARNING: Out of limit

This is displayed if the compensation data is out of the valid range when measuring the compensation data. The valid range for each type of compensation is as follows.

Type of compensation	Valid range
OPEN compensation	$ Y < 20 \mu\text{S}$
SHORT compensation	$ Z < 20 \Omega$
LOAD compensation	$ Z_{\text{ref}} \times 0.9 < Z < Z_{\text{ref}} \times 1.1$

In the above table, Y is the measured admittance value, Z is the measured impedance value, and Zref is the LOAD compensation standard definition value.

G **4268A vs. 4288A GPIB Command Correspondence Table**

This appendix gives the correspondence between the Agilent 4268A GPIB commands and those of the Agilent 4288A.

4268A vs. 4288A GPIB Command Correspondence Table

Table G-1 (by function) and Table G-2 (by alphabetical order) provide at-a-glance lists of the GPIB command correspondences between the 4268A and the 4288A.

Table G-1 At-a-glance GPIB command correspondence between 4268A and 4288A (by function)

Function	Item to Be Set Up/Executed		GPIB command		Note
			4268A	4288A	
Measurement condition	Reset		:SYST:PRES	←	The 4288A does not reset compensation data.
			*RST	←	
Measurement parameter setup	Primary parameter	:CALC1:FORM	←		
	Secondary parameter	:CALC2:FORM	←		
Measurement signal setup	Frequency	:SOUR:FREQ	←		
	1 MHz frequency shift	N/A	:SYST:FSH		
	Level	:SOUR:VOLT	←		
	Auto level control (ALC) function ON/OFF	:SOUR:VOLT:ALC	N/A	The 4288A does not support the ALC function.	
	Output mode	:SOUR:VOLT:MODE	N/A	The 4288A does not support the synchronous source function.	
Measurement range setup	Ranging (auto/manual)	:RANG:AUTO	←		
	Range	:RANG	←		
Measurement time mode setup		:APER	←		
Averaging setup	ON/OFF	:AVER	←		
	Number of counts	:AVER:COUN	←		
Cable length setup		:CAL:CABL	←		
Source delay setup		:TRIG:DEL	N/A	The 4288A supports only trigger delay.	
Trigger delay setup		:TRIG:SEQ2:DEL	:TRIG:DEL		
Trigger mode setup		:TRIG:SOUR	←		

Table G-1 At-a-glance GPIB command correspondence between 4268A and 4288A (by function)

Function	Item to Be Set Up/Executed		GPIB command		Note
			4268A	4288A	
Compensation	Entire compensation set ON/OFF		:CORR	N/A	The 4268A turns on/off all types of compensation. (Only the LOAD compensation can be turned on/off separately.) The 4288A turns on/off OPEN/SHORT/LOAD compensation individually.
	OPEN compensation ON/OFF		N/A	:CORR:OPEN	
	SHORT compensation ON/OFF		N/A	:CORR:SHOR	
	LOAD compensation ON/OFF		:CORR:COLL:METH	:CORR:LOAD	
	LOAD standard definition	Value setup	:CORR:CKIT:STAN3	←	
		Definition parameter setup	:CORR:CKIT:STAN3:FORM	←	
	Compensation data	Measurement	:CORR:COLL	←	
		setup and read out	:CORR:DATA	←	
	Offset compensation ON/OFF		N/A	:CORR:OFFS	The 4268A does not support the offset compensation.
Offset compensation data setup		N/A	:CORR:OFFS:DATA		
Scanner (multi compensation)	ON/OFF		:CORR:MULT	←	
	Channel setup		:CORR:MULT:CHAN	←	
	LOAD standard definition method setup		:CORR:MULT:CKIT:STAN3	←	
Trigger	Triggers a measurement		:TRIG,*TRG	←	
	Trigger mode setup		:TRIG:SOUR	←	
	Trigger delay time setup		:TRIG:SEQ2:DEL	:TRIG:DEL	
	Trigger system	Resets	:ABOR	←	
		Initiates	:INIT	←	
Continuous activation ON/OFF		:INIT:CONT	←		
Measured data output	Data transfer format setup		:FORM	←	The 4288A also controls data transfer format of compensation data.
	Data readout	Measurement result	:FETC?, :READ?	←	
		Data buffer	:DATA? {BUF1 BUF2}	←	The 4288A can also use BUF3.
		Measurement signal monitor result	:DATA? {IMON VMON}	←	
	Data buffer setup	Feeding target parameter	:DATA:FEED	←	
		Control (feed/not feed)	:DATA:FEED:CONT	←	
Buffer size		:DATA:POIN	←		

G. 4268A vs. 4288A
 GPIB Command
 Correspondence Table

[4268A vs. 4288A GPIB Command Correspondence Table](#)
[4268A vs. 4288A GPIB Command Correspondence Table](#)

Table G-1 At-a-glance GPIB command correspondence between 4268A and 4288A (by function)

Function	Item to Be Set Up/Executed		GPIB command		Note
			4268A	4288A	
Comparator	ON/OFF		:CALC:COMP	←	
	Limit range reset		N/A	:CALC:COMP:CLE	
	Primary parameter limit range setup	ON/OFF	:CALC:COMP:PRIM:BIN{1-9}:STAT	←	
		Lower/Upper Limit value	:CALC:COMP:PRIM:BIN{1-9}	←	
		Limit range designation method (mode selection)	:CALC:COMP:MODE	←	
		Reference (nominal) value	:CALC:COMP:PRIM:NOM	←	
	Secondary parameter limit range setup	ON/OFF	:CALC:COMP:SEC:STAT	←	
		Lower/Upper Limit value	:CALC:COMP:SEC:LIM	←	
	AUX BIN function ON/OFF		:CALC:COMP:AUXB	←	
	Low C reject function	ON/OFF	N/A	:CREJ	The 4268A does not support the Low C reject function.
		Limit value setup	N/A	:CREJ:LIM	
	BIN count function	ON/OFF	:CALC:COMP:COUN	←	
		Resets all count values	:CALC:COMP:COUN:CLE	←	
		Readout of count values	:CALC:COMP:COUN:DATA?	←	
		Readout of count value of overload	N/A	:CALC:COMP:COUN:OVLD?	The 4268A cannot count overload.
		Readout of count values for each channel	N/A	:CALC:COMP:COUN:MULT:DATA?	The 4268A cannot count for each channel.
		Readout of count value of overload for each channel	N/A	:CALC:COMP:COUN:MULT:OVLD?	
Measurement signal monitor	Current monitor	ON/OFF	:CALC3:MATH:STAT	←	
		Monitor value readout	:DATA? IMON	←	
	Voltage monitor	ON/OFF	:CALC4:MATH:STAT	←	
		Monitor value readout	:DATA? VMON	←	
Save/Recall	Save		*SAV	←	
	Recall		*RCL	←	

Table G-1 At-a-glance GPIB command correspondence between 4268A and 4288A (by function)

Function	Item to Be Set Up/Executed		GPIB command		Note	
			4268A	4288A		
Display	ON/OFF		:DISP	←		
	Number of digits setup		:DISP:TEXT1:DIG	←		
	Fixed point display setup	ON/OFF	N/A	:DISP:TEXT1:FMSD	The 4268A has a fixed floating point display.	
		the value of the highest digit	N/A	:DISP:TEXT1:FMSD:DATA		
	Deviation measurement mode setup	Primary parameter	ON/OFF	:CALC1:MATH:STAT	←	
			Mode	:CALC1:MATH:EXPR:NAME	←	
		Secondary parameter	ON/OFF	:CALC2:MATH:STAT	←	
Mode			:CALC2:MATH:EXPR:NAME	←		
Reference value		:DATA {REF1 REF2}	←			
Setup of displayed page of the instrument setup display area		:DISP:TEXT2:PAGE	←			
Contact check	ON/OFF		:CONT:VER	N/A	The 4288A does not support the contact check function.	
Key lock	ON/OFF		:SYST:KLOC	←		
Beeper	ON/OFF		:CALC:COMP:BEEP :SYST:BEEP:STAT	←		
	Beep mode setup		:CALC:COMP:BEEP:COND	←		
	Generation of a beep		:SYST:BEEP	←		
Status report structure	Clear		*CLS	←		
	Status byte register value readout		*STB?	←		
	Service request enable register setup		*SRE	←		
	Standard event status register	Register value readout		*ESR?	←	
		OPC bit setup		*OPC	←	
		Enable register setup		*ESE	←	
	Operation status register	Clear		:STAT:PRES	←	
		Condition register value readout		:STAT:OPER:COND?	←	
Enable register setup		:STAT:OPER:ENAB	←			
Event register value readout		:STAT:OPER?	←			
Others	Executes self-test		*TST?	←		
	Readout of the model name and firmware version		*IDN?	←		
	Readout of the installed option number		*OPT?	←		
	Reads 1 when operation completes		*OPC?	←		
	Readout of the occurred error information		:SYST:ERR?	←		
	Readout of SCPI version		:SYST:VERS?	←		
	Waits for the completion of operation		*WAI	←		

The “←” symbol in Table G-1 indicates that the value is the same as that of the 4268A.

4268A vs. 4288A GPIB Command Correspondence Table
4268A vs. 4288A GPIB Command Correspondence Table

Table G-2

At-a-glance GPIB command correspondence between 4268A and 4288A (by alphabetical order)

4268A	4288A
	[:A]
:ABORt	←
	[:C]
:CALCulate:COMParator:AUXBin	←
:CALCulate:COMParator:BEEPer:CONDition	←
:CALCulate:COMParator:BEEPer[:STATe]	←
:CALCulate:COMParator:COUNt:CLEar	←
:CALCulate:COMParator:COUNt:DATA?	←
:CALCulate:COMParator:COUNt[:STATe]	←
:CALCulate:COMParator:MODE	←
:CALCulate:COMParator:PRIMary:BIN{1-9}	←
:CALCulate:COMParator:PRIMary:BIN{1-9}:STATe	←
:CALCulate:COMParator:PRIMary:NOMinal	←
:CALCulate:COMParator:SECONdary:LIMit	←
:CALCulate:COMParator:SECONdary:STATe	←
:CALCulate:COMParator[:STATe]	←
:CALCulate1:FORMat	←
:CALCulate1:MATH:EXPRession:CATalog?	←
:CALCulate1:MATH:EXPRession:NAME	←
:CALCulate1:MATH:STATe	←
:CALCulate2:FORMat	←
:CALCulate2:MATH:EXPRession:CATalog?	←
:CALCulate2:MATH:EXPRession:NAME	←
:CALCulate2:MATH:STATe	←
:CALCulate3:MATH:STATe	←
:CALCulate4:MATH:STATe	←
:CALibration:CABLe	←
	[:D]
:DATA[:DATA]	←
:DATA:FEED	←
:DATA:FEED:CONTRol	←
:DATA:POINts	←
:DISPlay[:WINDow][:STATe]	←
:DISPlay[:WINDow]:TEXT1[:DATA]:DIGit	←
:DISPlay[:WINDow]:TEXT2:PAGE	←
	[:F]
:FETCh?	←
:FORMat[:DATA]	←
	[:I]
:INITiate:CONTinuous	←
:INITiate[:IMMediate]	←
	[:R]
:READ?	←
	[:S]
[:SENSe]:AVERage:COUNt	←
[:SENSe]:AVERage[:STATe]	←
[:SENSe]:CORRection:CKIT:STANdard3	←
[:SENSe]:CORRection:CKIT:STANdard3:FORMat	←
[:SENSe]:CORRection:COLLect:METHod	[:SENSe]:CORRection:LOAD[:STATe]
[:SENSe]:CORRection:COLLect[:ACQuire]	←
[:SENSe]:CORRection:DATA	←
[:SENSe]:CORRection:MULTiple:CHANnel	←
[:SENSe]:CORRection:MULTiple:CKIT:STANdard3[:STATe]	←

Table G-2

At-a-glance GPIB command correspondence between 4268A and 4288A (by alphabetical order)

4268A	4288A
[:SENSe]:CORRection:MuLTiple[:STATe]	←
[:SENSe]:CORRection[:STATe]	N/A
[:SENSe][:FIMPedance]:APERture[:MODE]	←
[:SENSe][:FIMPedance]:CONtact:VERify	N/A
[:SENSe][:FIMPedance]:RANGe:AUTO	←
[:SENSe][:FIMPedance]:RANGe[:UPPer]	←
:SOURce:FREQuency[:CW]	←
:SOURce:VOLTagE:ALC[:STATe]	N/A
:SOURce:VOLTagE[:LEVel][:IMMediate][:AMPLitude]	←
:SOURce:VOLTagE:MODE	N/A
:STATus:OPERation:CONDition?	←
:STATus:OPERation:ENABle	←
:STATus:OPERation[:EVENT]?	←
:STATus:PRESet	←
:STATus:QUEStionable:CONDition?	←
:STATus:QUEStionable:ENABle	←
:STATus:QUEStionable[:EVENT]?	←
:SYSTem:BEEPer[:IMMediate]	←
:SYSTem:BEEPer:STATe	←
:SYSTem:ERRor?	←
:SYSTem:KLOCK	←
:SYSTem:PRESet	←
:SYSTem:VERSion?	←
[:T]	
:TRIGger[:SEQuence1]:DELay	N/A
:TRIGger[:SEQuence1]:SOURce	←
:TRIGger[:SEQuence1][:IMMediate]	←
:TRIGger:SEQuence2:DELay	:TRIGger[:SEQuence1]:DELay
[*]	
*CLS	←
*ESE	←
*ESR?	←
*IDN?	←
*OPC	←
*OPC?	←
*OPT?	←
*RCL	←
*RST	←
*SAV	←
*SRE	←
*STB?	←
*TRG	←
*TST?	←
*WAI	←

The “←” symbol in Table G-2 indicates that the value is the same as that of the 4268A.

G 4268A vs. 4288A
 GPIB Command
 Correspondence Table

4268A vs. 4288A GPIB Command Correspondence Table
4268A vs. 4288A GPIB Command Correspondence Table

Numerics

4268A, 274
 4278A vs. 4288A(functional comparison)
 At-a-Glance List of GPIB Command Correspondence, 238
 Averaging, 216
 Cable length, 216
 Comparator, 221
 Compensation, 218
 Display, 224
 Example of Replacing, 232
 Handler interface, 244
 HI-ACC mode, 213
 Measurement parameter, 212
 Measurement range, 214
 Measurement signal, 213
 Measurement time, 216
 Multi compensation, 220
 Reading out the measurement result, 228
 Reset, 212
 Resume, 230
 Save/recall, 230
 Scanner interface, 245
 Status register, 230
 Trigger delay time, 217
 Trigger mode, 217
 64-bit floating-point data, 60

A

Absolute mode, 82
 Absolute tolerance mode, 82
 Address, 20
 Alarm (beep)
 How to make, 29
 ASCII transfer format, 59
 Auto range, 25
 AUX BIN function, 84
 Averaging, 25

B

Basic capacitor measurement, 102
 Beep, 29
 How to make, 29
 BIN count, 88
 Bin sorting, 81
 Binary transfer format
 Byte order, 60
 format, 60
 Comparison between 4278A and 4288A, 229
 Buck-up, 258
 Buffer, 75
 Bus trigger, 53
 Byte order, 60

C

Cable length, 25
 Channel, 46

Clear

BIN count value, 88
 Error queue, 124
 Limit range, 82
 Status register, 124
 Command tree
 4288A command tree, 203
 Concept, 21
 comp_dat.bas, 44
 Comparator, 81
 BIN count, 88
 Functional comparison, 221
 Low C reject, 85
 Setup, 82
 Sorting result
 Overload/Low C, 262
 Readout, 86
 compen.bas, 40
 Compensation, 35
 Functional comparison, 218
 comprtr.bas, 91
 Condition register, 250
 Correction meas failed, 266
 Cp, 24
 Cs, 24
 Current level monitor, 28

D

D, 24
 Data buffer, 75
 Data transfer format, 58
 Comparison between 4278A and 4288A, 229
 data_buf.bas, 77
 Delay time, 25
 Deviation measurement mode, 27
 Device selector, 19
 Digits, 26
 Display, 26
 Functional comparison, 224
 Display page, 26

E

Enable register, 249
 Error code, 98
 Error message
 How to read out, 95
 Error messages
 Error messages, 264
 Warning messages, 272
 Error queue, 95
 Event register, 249
 Example of Replacing, 232
 External test, 98
 External trigger, 53

F

Factory settings, 258
FAIL, 29
Feed, 75
fetch_a.bas, 67
Firmware version, 208
Firmware(F/W) version, 125
Fixed point display, 26
Format, 58
Frequency
 How to set up, 24
 Shift, 192
Front panel key
 GPIB command vs. key, 123
 Key tree vs. GPIB command, 201
Functional comparison, 212

G

G, 24
GPIB, 18
GPIB address, 20
GPIB command
 *CLS, 124
 *ESE, 124
 *ESR?, 125
 *IDN?, 125
 *OPC, 125
 *OPC?, 125
 *OPT?, 126
 *RCL, 126
 *RST, 126
 *SAV, 127
 *SRE, 127
 *STB?, 128
 *TRG, 128
 *TST?, 129
 *WAI, 129
:ABORt, 130
:CALCulate:COMParator:AUXBin, 135
:CALCulate:COMParator:BEEPer:CONDition, 136
:CALCulate:COMParator:BEEPer[:STATe], 135
:CALCulate:COMParator:CLEAr, 136
:CALCulate:COMParator:COUNT:CLEAr, 137
:CALCulate:COMParator:COUNT:DATA?, 138
:CALCulate:COMParator:COUNT:MULTi:DATA?, 139
:CALCulate:COMParator:COUNT:MULTi:OVLD?, 140
:CALCulate:COMParator:COUNT:OVLD?, 140
:CALCulate:COMParator:COUNT[:STATe], 137
:CALCulate:COMParator:MODE, 141
:CALCulate:COMParator:PRIMary:BIN{1-9}, 142
:CALCulate:COMParator:PRIMary:BIN{1-9}:STATe,
 143
:CALCulate:COMParator:PRIMary:NOMinal, 144
:CALCulate:COMParator:SECOndary:LIMit, 145
:CALCulate:COMParator:SECOndary:STATe, 146
:CALCulate:COMParator[:STATe], 134
:CALCulate1:FORMAt, 147

:CALCulate1:MATH:EXPRession:CATalog?, 147
:CALCulate1:MATH:EXPRession:NAME, 148
:CALCulate1:MATH:STATe, 149
:CALCulate2:FORMAt, 150
:CALCulate2:MATH:EXPRession:CATalog?, 150
:CALCulate2:MATH:EXPRession:NAME, 151
:CALCulate2:MATH:STATe, 152
:CALCulate3:MATH:STATe, 153
:CALCulate4:MATH:STATe, 153
:CALibration:CABLe, 133
:DATA[:DATA], 168
 :DATA[:DATA]? {BUF1|BUF2}, 168
 :DATA[:DATA]? {IMON|VMON}, 171
 :DATA[:DATA]? {REF1|REF2}, 172
:DATA:FEED, 173
:DATA:FEED:CONTRol, 174
:DATA:POINts, 175
:DISPlay[:WINDow][:STATe], 176
:DISPlay[:WINDow]:TEXT1[:DATA]:DIGit, 176
:DISPlay[:WINDow]:TEXT1[:DATA]:FMSD:DATA, 178
:DISPlay[:WINDow]:TEXT1[:DATA]:FMSD[:STATe],
 177
:DISPlay[:WINDow]:TEXT2:PAGE, 179
:FETCh?, 181
:FORMAt[:DATA], 182
:INITiate:CONTInuous, 183
:INITiate[:IMMediate], 183
:READ?, 186
[:SENSe]:AVERAge:COUNT, 132
[:SENSe]:AVERAge[:STATe], 131
[:SENSe]:CORRection:CKIT:STANdard1:FORMAt, 154
[:SENSe]:CORRection:CKIT:STANdard2:FORMAt, 154
[:SENSe]:CORRection:CKIT:STANdard3, 155
[:SENSe]:CORRection:CKIT:STANdard3:FORMAt, 156
[:SENSe]:CORRection:COLLect[:ACQuire], 157
[:SENSe]:CORRection:DATA, 158
[:SENSe]:CORRection:LOAD[:STATe], 160
[:SENSe]:CORRection:MULTiple:CHANnel, 161
[:SENSe]:CORRection:MULTiple:CKIT:STANdard3[:ST
 ATe], 162
[:SENSe]:CORRection:MULTiple[:STATe], 161
[:SENSe]:CORRection:OFFSet:DATA, 164
[:SENSe]:CORRection:OFFSet[:STATe], 163
[:SENSe]:CORRection:OPEN[:STATe], 165
[:SENSe]:CORRection:SHORT[:STATe], 165
[:SENSe][:FIMPedance]:APERture[:MODE], 130
[:SENSe][:FIMPedance]:CREJect:LIMit, 167
[:SENSe][:FIMPedance]:CREJect[:STATe], 166
[:SENSe][:FIMPedance]:RANGe:AUTO, 185
[:SENSe][:FIMPedance]:RANGe[:UPPer], 184
:SOURce:FREQUency[:CW], 187
:SOURce:VOLTag[:LEVel][:IMMediate][:AMPLitude],
 188
:STATus:OPERation:CONDition?, 189
:STATus:OPERation:ENABle, 189
:STATus:OPERation[:EVENT]?, 189
:STATus:PRESet, 190

- :STATus:QUEStionable:CONDition?, 190
 - :STATus:QUEStionable:ENABle, 190
 - :STATus:QUEStionable[:EVENT]?, 190
 - :SYSTem:BEEPer[:IMMEDIATE], 191
 - :SYSTem:BEEPer:STATe, 191
 - :SYSTem:ERRor?, 192
 - :SYSTem:FSHift, 192
 - :SYSTem:KLOCK, 193
 - :SYSTem:PRESet, 193
 - :SYSTem:TEST?, 194
 - :SYSTem:VERSion?, 194
 - :TRIGer[:SEQUENCE1]:DELay, 195
 - :TRIGer[:SEQUENCE1][:IMMEDIATE], 195
 - :TRIGer[:SEQUENCE1]:SOURce, 196
 - 4278A vs. 4288A, 238
 - Command reference
 - 4288A GPIB command, 130
 - IEEE common commands, 124
 - Notational conventions, 122
 - GPIB command table, 197
 - GPIB command tree, 203
 - GPIB command vs. front panel key, 123
 - GPIB commands
 - Lookup, 14
 - GPIB trigger, 53
- H**
- Handler interface, 244
 - Highest digit, 26
 - Hold range, 25
 - How to use this manual, 14
- I**
- Idle state, 52
 - Information for Replacing 4278A with 4288A, 211
 - Initial settings, 258
 - Initialization
 - Instrument setting, 126
 - Status register, 124
 - Instrument setup display area, 26
 - Interface, 244
 - Internal test, 98
 - Internal trigger, 53
- K**
- Key lock function, 94
 - Key tree vs. GPIB command, 201
- L**
- Level
 - How to set up, 24
 - Monitor
 - On/Off, 28
 - Reading out result, 79
 - Limit range, 82
 - Limit range designation method, 82
- LOAD compensation, 36
 - Long mode, 25
 - Looking up commands, 14
 - Low C reject, 85
 - LOWC, 262
- M**
- Manual change, 208
 - Manual trigger, 53
 - meas_fxt.bas, 103
 - meas_scn.bas, 116
 - meas_sys.bas, 108
 - Measured result
 - Display, 27
 - Reading out, 61
 - Measurement parameter, 24
 - Measurement range, 25
 - Measurement signal, 24
 - Measurement state, 53
 - Measurement status, 181
 - Measurement time, 25
 - Measurement with auto sorting system, 106
 - Measurement with changing channels, 113
 - Message terminator, 21
 - Migration (4278A->4288A), 211
 - Monitor
 - On/Off, 28
 - Reading out result, 79
 - Msd, 26
 - Multi compensation, 46
 - multi.bas, 48
 - Multi-command messages, 22
- N**
- Need corr meas, 272
 - Need load meas, 272
 - Need open meas, 272
 - Need short meas, 272
 - Negative transition filter, 250
 - Number of display digits, 26
- O**
- Offset compensation, 45
 - OPEN compensation, 36
 - Operation manual, 4
 - Operation status register, 251
 - Bit definitions, 254
 - Out of limit, 272
 - Overload, 262
 - OVLd, 262
- P**
- Page, 26
 - Parameter, 24
 - GPIB command, 122
 - PASS, 29

-
- Percent tolerance mode, 82
 - Pin assignment
 - Handler interface, 244
 - Scanner interface, 245
 - Positive transition filter, 250
 - Prefix, 208
 - Preset, 126
 - Preset value, 258
 - Press, 20
 - Primary parameter, 24
 - Product information, 125
 - Program(sample)
 - File name
 - comp_dat.bas, 44
 - compen.bas, 40
 - comprtr.bas, 91
 - data_buf.bas, 77
 - fetch_a.bas, 67
 - fetch_b.bas, 69
 - lvl_mon.bas, 80
 - meas_fxt.bas, 103
 - meas_scn.bas, 116
 - meas_sys.bas, 108
 - multi.bas, 48
 - read_a.bas, 71
 - read_b.bas, 73
 - selftest.bas, 99
 - setup.bas, 33
 - srq_err.bas, 97
 - srq_meas.bas, 56
 - trg_a.bas, 63
 - trg_b.bas, 65
 - Title
 - Capacitor measurement using the test fixture, 103
 - Detecting the completion of measurement using SRQ, 56
 - Error occurrence detection using SRQ, 97
 - Executing the multi compensation, 48
 - Executing the OPEN/SHORT/LOAD compensation, 40
 - Executing the self test, 99
 - Measurement assuming the auto sorting system, 108
 - Reading out measured result in ASCII transfer format using *TRG command, 63
 - Reading out measured result in ASCII transfer format using :FETC? command, 67
 - Reading out measured result in ASCII transfer format using :READ? command, 71
 - Reading out measured result in binary transfer format using :FETC? command, 69
 - Reading out measured result in binary transfer format using :READ? command, 73
 - Reading out measured result using data buffer, 77
 - Reading out measurement signal level monitor result, 80
 - Reading out the measured result in binary transfer format using *TRG command, 65
 - Recovering the compensation state, 44
 - Scanning measurement, 116
 - Setting up measurement conditions and display, 33
 - Sorting using comparator function, 91
- ## Q
- Q, 24
 - Questionable status register, 251
 - Bit definitions, 254
- ## R
- Range, 25
 - :READ? command, 70
 - Trigge input timing, 74
 - read_a.bas, 71
 - read_b.bas, 73
 - Reading out
 - Measurement parameter, 61
 - Reading out data
 - Measurement parameter, 61
 - Recall
 - GPIB command, 126
 - How to execute, 30
 - Settings that can be recalled, 258
 - Remote mode, 94
 - Replacing 4278A with 4288A, 211
 - Reset
 - 4288A
 - Initial settings, 258
 - BIN count value, 88
 - Error queue, 124
 - Instrument setting, 126
 - Limit range, 82
 - Status register, 124
 - Resume function
 - Settings that can be backed up, 258
 - Rp, 24
 - Rs, 24
- ## S
- Sample program
 - File name
 - comp_dat.bas, 44
 - compen.bas, 40
 - comprtr.bas, 91
 - data_buf.bas, 77
 - fetch_b.bas, 69
 - lvl_mon.bas, 80
 - meas_fxt.bas, 103
 - meas_scn.bas, 116
 - meas_sys.bas, 108
 - multi.bas, 48
 - read_a.bas, 71
 - read_b.bas, 73
 - selftest.bas, 99
 - setup.bas, 33
 - srq_err.bas, 97
 - srq_meas.bas, 56
 - trg_a.bas, 63

- trg_b.bas, 65
 - How to load, 15
 - Title
 - Capacitor measurement using the test fixture, 103
 - Detecting the completion of measurement using SRQ, 56
 - Error occurrence detection using SRQ, 97
 - Executing the multi compensation, 48
 - Executing the OPEN/SHORT/LOAD compensation, 40
 - Executing the self test, 99
 - Measurement assuming the auto sorting system, 108
 - Reading out measured result in ASCII transfer format using *TRG command, 63
 - Reading out measured result in ASCII transfer format using :FETC? command, 67
 - Reading out measured result in ASCII transfer format using :READ? command, 71
 - Reading out measured result in binary transfer format using *TRG command, 65
 - Reading out measured result in binary transfer format using :FETC? Command, 69
 - Reading out measured result in binary transfer format using :READ? command, 73
 - Reading out measured result using data buffer, 77
 - Reading out measurement signal level monitor result, 80
 - Recovering the compensation state, 44
 - Scanning measurement, 116
 - Setting up measurement conditions and display, 33
 - Sorting using comparator function, 91
 - Save
 - GPIB command, 127
 - How to execute, 30
 - Settings that can be saved, 258
 - Scanner interface, 245
 - Scanning, 113
 - Secondary parameter, 24
 - Self test, 98
 - selftest.bas, 99
 - Sequence operation state, 53
 - Serial number, 208
 - GPIB command, 125
 - Plate, 208
 - Service request, 248
 - Example
 - Error detection, 95
 - Waiting for completion of measurement, 55
 - Service Request Enable Register
 - Set, 127
 - Service request enable register, 248, 249
 - setup.bas, 33
 - Several measurements readout, 75
 - Shift, 192
 - SHORT compensation, 36
 - Short mode, 25
 - Sorting, 81
 - Sorting result
 - Readout, 86
 - SRQ, 248
 - Example
 - Error detection, 95
 - Waiting for completion of measurement, 55
 - srq_err.bas, 97
 - srq_meas.bas, 56
 - Standard Event Status Register
 - Read out, 125
 - Set Enable Register, 124
 - Standard event status register, 251
 - Bit definitions, 253
 - Starting measurement, 54
 - Status Byte Register
 - Read out, 128
 - Status byte register, 249
 - Bit definitions, 252
 - Status register
 - Example
 - Error detection, 95
 - Waiting for completion of measurement, 55
 - Model, 248
 - Register structure, 251
 - Status reporting system, 248
- T**
- Test, 98
 - Tolerance mode, 82
 - Transfer format, 58
 - Transition filter, 250
 - trg_a.bas, 63
 - trg_b.bas, 65
 - Trigger delay time, 25
 - Trigger event detect state, 53
 - Trigger mode, 53
 - Trigger system, 52
 - Triggering measurement, 54
- U**
- Unlock, 94
- V**
- Voltage level monitor, 28
- W**
- Waiting for completion of measurement, 55
 - Waiting for trigger state, 53
 - Warning messages(WARNING), 272

REGIONAL SALES AND SUPPORT OFFICES

For more information about Agilent Technologies test and measurement products, applications, services, and for a current sales office listing, visit our web site: <http://www.agilent.com/find/tmdir>. You can also contact one of the following centers and ask for a test and measurement sales representative. 11/29/99

United States:

Agilent Technologies
Test and Measurement Call Center
P.O.Box 4026
Englewood, CO 80155-4026
(tel) 1 800 452 4844

(fax) (61 3) 9272 0749
(tel) 0 800 738 378 (New Zealand)
(fax) (64 4) 802 6881

Canada:

Agilent Technologies Canada Inc.
5150 Spectrum Way
Mississauga, Ontario
L4W 5G1
(tel) 1 877 894 4414

Asia Pacific:

Agilent Technologies
24/F, Cityplaza One, 1111 King's Road,
Taikoo Shing, Hong Kong
(tel) (852)-3197-7777
(fax) (852)-2506-9284

Europe:

Agilent Technologies
Test & Measurement
European Marketing Organization
P.O.Box 999
1180 AZ Amstelveen
The Netherlands
(tel) (31 20) 547 9999

Japan:

Agilent Technologies Japan Ltd.
Call Center
9-1, Takakura-Cho, Hachioji-Shi,
Tokyo 192-8510, Japan
(tel) (81) 426 56 7832
(fax) (81) 426 56 7840

Latin America:

Agilent Technologies
Latin American Region Headquarters
5200 Blue Lagoon Drive, Suite #950
Miami, Florida 33126
U.S.A.
(tel) (305) 267 4245
(fax) (305) 267 4286

Australia/New Zealand:

Agilent Technologies Australia Pty Ltd
347 Burwood Highway
Forest Hill, Victoria 3131
(tel) 1-800 629 485 (Australia)